

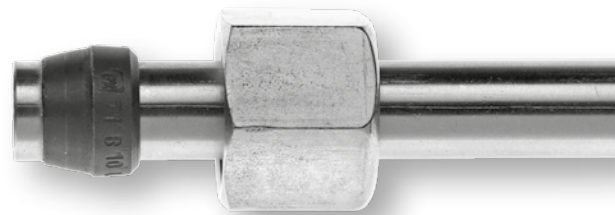

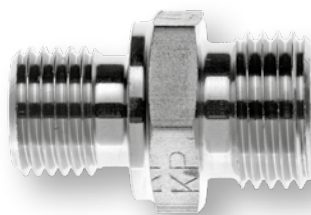

















Schneidring-  
verschraubungen

Cutting ring  
fittings

Racores de anillo  
cortante



Seite/Page/Página	Seite/Page/Página	Seite/Page/Página
<p><b>Rohrverschraubungen</b> <b>Tube fittings</b> <b>Racores de conexión</b></p>	<p>Winkel-Schottverschraubungen Bulkhead elbow fittings Racores pasatabiques a codo</p>	<p><b>Einstellbare Verschraubungen</b> <b>Adjustable fittings</b> <b>Racores ajustables</b></p>
	<p>10.19-10.20</p> 	
	<p><b>WSV</b></p>	
<p>Gerade Verschraubungen Straight fittings Racores rectos</p>	<p>10.5-10.6</p> 	<p><b>Einschraubverschraubungen</b> <b>Male adaptor fittings</b> <b>Racores para rosar</b></p>
	<p><b>GV</b></p>	<p>Gerade Einschraubstutzen mit Dichtkegel Straight male adaptor unions with taper Racores para rosar rectos con junta cónica</p>
		<p>10.84-10.86</p> 
		<p><b>EGKO</b></p>
<p>Winkelverschraubungen Elbow fittings Racores codo</p>	<p>10.7-10.8</p> 	<p>Gerade Einschraubverschraubungen Straight male adaptor fittings Racores para rosar rectos</p>
	<p><b>WV</b></p>	<p>10.21-10.56</p> 
		<p>Einschraubstutzen mit Schaft Male adaptor standpipe unions Racores para rosar con vástago</p>
		<p>10.87-10.96</p> 
		<p><b>ESS</b></p>
<p>T-Verschraubungen T fittings Racores T</p>	<p>10.9-10.10</p> 	<p>Winkel-Einschraubverschraubungen Male adaptor elbow fittings Racores para rosar en codo</p>
	<p><b>TV</b></p>	<p>10.57-10.68</p> 
		<p>Einstellbare Winkelverschraubungen Adjustable elbow fittings Racores angulares ajustables</p>
		<p>10.97-10.104</p> 
		<p><b>EWKO/EWV</b></p>
<p>Kreuz-Verschraubungen Cross fittings Racores en cruz</p>	<p>10.11-10.12</p> 	<p>T-Einschraubverschraubungen Male adaptor T fittings Racores para rosar T</p>
	<p><b>KV</b></p>	<p>10.69-10.74</p> 
		<p>Einstellbare Winkel-Einschraubverschraubungen Adjustable male adaptor elbow fittings Racores para rosar en codo ajustables</p>
		<p>10.105-10.106</p> 
		<p><b>WEE</b></p>
<p>Verschlussverschraubungen Caps Racores de cierre</p>	<p>10.13-10.14</p> 	<p>L-Einschraubverschraubungen Male adaptor L fittings Racores para rosar L</p>
	<p><b>VSA</b></p>	<p>10.75-10.80</p> 
		<p>Einstellbare T-/L-Verschraubungen Adjustable T/L fittings Racores T/L ajustables</p>
		<p>10.107-10.118</p> 
		<p><b>ETKO/ETV / ELKO/ELV</b></p>
<p>Gerade Zwischenstutzen mit Dichtkegel Straight unions with taper Racores de unión rectos con junta cónica</p>	<p>10.15</p> 	<p>Gerade Thermoelementverschraubungen Straight fittings for temperature sensors Racores de termsonda</p>
	<p><b>VKO</b></p>	<p>10.81-10.83</p> 
		<p><b>Schwenkverschraubungen</b> <b>Banjo fittings</b> <b>Racores orientables</b></p>
		<p><b>GEV-D</b></p>
<p>Gerade Schottverschraubungen Bulkhead fittings Racores pasatabiques rectos</p>	<p>10.17-10.18</p> 	<p>Winkel-Schwenkverschraubungen Banjo elbow fittings Racores orientables angulares</p>
	<p><b>GSV</b></p>	<p>10.119-10.126</p> 
		<p><b>ESWV</b></p>

Seite/Page/Página

Seite/Page/Página

Seite/Page/Página

**Aufschraub-/Manometerverschr.  
Female adaptor/Manometer fittings  
Racores rectos/para manómetro**

**Anschweißverschraubungen  
Weldable fittings  
Racores para soldar**

Verschlusschrauben  
Locking screws  
Tornillos de cierre

10.187-10.192



VSI/VSS

10.127-10.132  
Gerade Aufschraubverschraubungen  
Straight female adaptor fittings  
Racores atornillables rectos



GAV

10.171-10.174  
Gerade Anschweißverschraubungen  
Straight weld-on fittings  
Racores para soldar rectos



GAS/GASK

Verschlussstopfen  
Blanking plugs  
Tapónes

10.193-10.194



VOE/VME

10.133-10.136  
Manometer-Anschlussverschraubungen  
Manometer fittings  
Racores para manómetro



MAV

10.175-10.176  
Winkelanschweißverschraubungen  
Elbow weld-on fittings  
Racores para soldar angulares



WAS

Überwurfmuttern  
Nuts  
Tuercas de unión

10.195



UEM

10.138-10.142  
Einstellbare Manometer-Anschlussstutzen  
vormontiert  
Adjustable manometer fittings pre-assembled  
Racores para manómetro ajustables premontado



EMAKO/EMAS

10.177-10.178  
Einschweiß-Schottverschraubungen  
Weld-in bulkhead fittings  
Racores de paso de mamparo para soldar



ESV

Schneidringe  
Cutting rings  
Anillos cortantes

10.196



SR

10.143-10.146  
Gerade Messverschraubungen  
Straight fittings with test gauge  
Racores de medición rectos



EMV

10.179-10.181  
Schweißkegel  
Weldable cones  
Conos para soldar



SKO/SKR

Kontermuttern  
Counter nuts  
Contratuercas

10.197



KM

**Reduzierschraubungen  
Reducing fittings  
Racores de reducción**

**Einzelteile  
Single parts  
Componentes**

Dichtkantenringe  
Seal edge rings  
Anillos con borde de obturación

10.198-10.199



EDKR/DKR

10.147-10.168  
Gerade Reduzierschraubungen  
Straight reducing fittings  
Racores de reducción rectos



GRKO/GR/KR

10.182  
Verstärkungshülsen  
Reinforcing sleeves  
Manguitos de refuerzo



VHS

Profildichtringe/O-Ringe  
Profile sealing rings/O-rings  
Juntas anulares con perfil/Juntas tóricas

10.200-10.201



VDR/VOR

10.169-10.170  
T-Reduzierschraubungen  
Reducing T fittings  
Racores de reducción T



TR

10.183-10.186  
Gewinde-Reduzierstutzen  
Reducing adaptors  
Racores de reducción roscados



RS

Schneidringverschraubungen

Cutting ring fittings

Racores de anillo cortante

**Eigenschaften, Besonderheiten**

- nach ISO 8434-1/DIN 2353
- Baureihen LL, L und S
- korrosionsbeständig
- große Sortimentsvielfalt

**Characteristics, specialities**

- according to ISO 8434-1/DIN 2353
- series LL, L and S
- corrosion resistant
- large range of products

**Características, particularidades**

- según ISO 8434-1/DIN 2353
- series LL, L y S
- resistencia a la corrosión
- amplio surtido

**Funktionsprinzip**

siehe Kapitel a für Details

**Operating principle**

see chapter a for details

**Principio de funcionamiento**

para más detalles, consulte el capítulo a

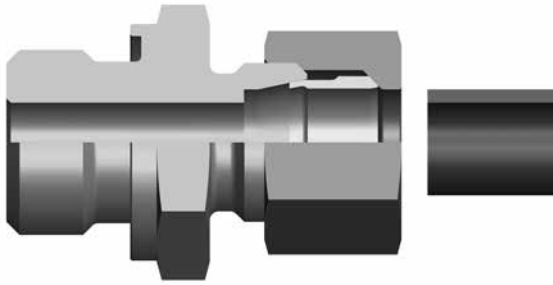

Vor der Montage  
Before assembly  
Antes del montaje

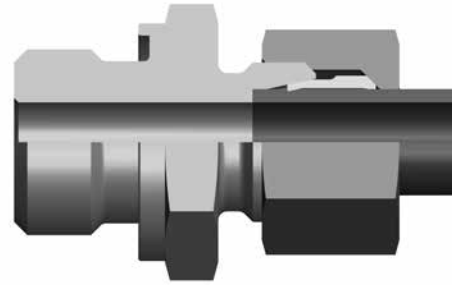

Nach der Montage  
After assembly  
Después del montaje

**Werkstoff**

Edelstahl 1.4571,  
Legierung X 6 CrNiMoTi 17 12 2,  
≈ AISI 316 Ti.  
Andere hochwertige Werkstoffqualitäten (Hastelloy®, Monel®, Titan, etc.) sind möglich.

**Material**

Stainless steel 1.4571,  
alloy X 6 CrNiMoTi 17 12 2,  
≈ AISI 316 Ti.  
Other high quality materials (Hastelloy®, Monel®, Titan, etc.) also available.

**Material**

Acero inoxidable 1.4571,  
aleación X 6 CrNiMoTi 17 12 2,  
≈ AISI 316 Ti.  
Posibilidad de otros materiales de calidad (Hastelloy®, Monel®, titanio, etc.)

**Nenndruck PN**

bis 800 bar gemäß DNV GL

**Pressure nominal PN**

up to 800 bar according to DNV GL

**Presión nominal PN**

hasta 800 bar según DNV GL

**Druckbereiche für Schneidringverschraubungen**

Baureihe	Rohr	Nenndruck
LL: sehr leicht	4 - 12 mm	PN 100 (bar)
L: leicht	6 - 10 mm	PN 500 (bar)
	12 - 18 mm	PN 400 (bar)
	22 - 42 mm	PN 250 (bar)
S: schwer	6 - 10 mm	PN 800 (bar)
	12 - 16 mm	PN 630 (bar)
	20 - 38 mm	PN 420 (bar)

**Pressure range for Cutting ring fittings**

Serie	Tube	Pressure nom.
LL: extra light	4 - 12 mm	PN 100 (bar)
L: light	6 - 10 mm	PN 500 (bar)
	12 - 18 mm	PN 400 (bar)
	22 - 42 mm	PN 250 (bar)
S: heavy	6 - 10 mm	PN 800 (bar)
	12 - 16 mm	PN 630 (bar)
	20 - 38 mm	PN 420 (bar)

**Rangos de presión para Racores de anillo cortante**

Serie	Tubo	Presión nom.
LL: muy ligera	4 - 12 mm	PN 100 (bar)
L: ligera	6 - 10 mm	PN 500 (bar)
	12 - 18 mm	PN 400 (bar)
	22 - 42 mm	PN 250 (bar)
S: pesada	6 - 10 mm	PN 800 (bar)
	12 - 16 mm	PN 630 (bar)
	20 - 38 mm	PN 420 (bar)

**Druckbereiche für Dichtkegelverschraubungen**

Baureihe	Rohr	Nenndruck
L: leicht	6 - 18 mm	PN 315 (bar)
	22 - 42 mm	PN 160 (bar)
S: schwer	6 - 14 mm	PN 630 (bar)
	16 - 30 mm	PN 400 (bar)
	38 mm	PN 315 (bar)

**Pressure range for Tapered seal fittings**

Serie	Tube	Pressure nom.
L: light	6 - 18 mm	PN 315 (bar)
	22 - 42 mm	PN 160 (bar)
S: heavy	6 - 14 mm	PN 630 (bar)
	16 - 30 mm	PN 400 (bar)
	38 mm	PN 315 (bar)

**Rangos de presión para Racores cónicos**

Serie	Tubo	Presión nom.
L: ligera	6 - 18 mm	PN 315 (bar)
	22 - 42 mm	PN 160 (bar)
S: pesada	6 - 14 mm	PN 630 (bar)
	16 - 30 mm	PN 400 (bar)
	38 mm	PN 315 (bar)

**Druckauswertungsgrad  
in % des PN**

**Pressure coefficient  
in % of PN**

**Grado de valoración de presión  
en % de la PN**

°C									
-196°	-110°	-60°	0°	20°	50°	100°	200°	300°	400°
50 %	70 %	100 %	95.5 %	89 %	80 %	71 %	67 %		

**Temperaturbereich**

-196°C bis +400°C  
Achtung: Ausnahmen bilden weichgedichtete (Zusatz "WD") oder Dichtkegel-Verschraubungen (Zusatz "KO"), die nur in einem Bereich von -20°C bis +200°C eingesetzt werden können.

**Temperature range**

-196°C to +400°C  
Attention: Excepted are FKM-sealed fittings (suppl. "WD") and fittings with taper (suppl. "KO"), which can be used only in a range from -20°C up to +200°C.

**Intervalo de temperatura**

de -196°C a +400°C  
Atención: La excepción son los racores con juntas blandas (código "WD") o de junta cónica (código "KO"), aptos solo para un rango de temperaturas de -20°C hasta +200°C.

**Helium-Leckrate**

mind. 10<sup>6</sup> mbar • l/s bei fachgerechter Montage; siehe Kapitel a für Montageanleitung.

**Helium leak rate**

10<sup>6</sup> mbar • l/s min. when professionally assembled; see chapter a for installation instructions.

**Tasa de fuga de helio**

mín. 10<sup>6</sup> mbar • l/s con montaje correcto; para las instrucciones de montaje, consulte el capítulo a.

**Vakuum**

bis 10<sup>4</sup> mbar, höhere Werte möglich

**Vacuum**

up to 10<sup>4</sup> mbar, higher values are possible

**Vacío**

hasta 10<sup>4</sup> mbar; posibilidad de valores superiores

**Anzuschließende Rohre**

Nahtlose gezogene Präzisionsrohre aus Edelstahl (DIN EN 10216-5/EN ISO 1127, Toleranzkl. D4/T4) mit sauberer, glatter Oberfläche oder Kunststoffrohre. Außendurchmesser innerhalb ± 0,1 mm; Ausnahme: Kunststoffrohre. Siehe auch Kapitel Rohre und Schläuche. Weitere Materialien auf Anfrage.

**Tubes to use**

Seamless, cold-drawn, high precision stainless steel tubes (according to DIN EN 10216-5/EN ISO 1127 tolerance class D4/T4) with clean, smooth surface or plastic tubes. Outer diameter within ± 0,1 mm; exception: plastic tubes. See also chapter tubes and hoses. Other materials on request.

**Tubos para conectar**

Tubos de precisión estirados sin costuras, de acero inoxidable (DIN EN 10216-5/EN ISO 1127, clase de tolerancia D4/T4) con superficie lisa limpia o tubos de plástico. Diámetro exterior con tolerancia de ± 0,1 mm; excepción: tubos de plástico. Véase también el capítulo Tubos y mangueras. Otros materiales bajo demanda.

**Werkzeugnis**

Werden Bescheinigungen über Materialprüfungen nach DIN EN 10 204 gewünscht, so ist dies bei Bestellung anzugeben (ab Abnahmeprüfzeugnis 3.1 gegen Berechnung).

**Material certificates**

Inform us with your order if you need material testing certificates according to DIN EN 10204 (charges apply to inspection certificates 3.1 and higher).

**Certificado de material**

Si se necesitan certificados de ensayos de material según DIN EN 10 204, deberá especificarse al realizar el pedido (se facturará a partir del certificado de recepción 3.1).

**Zulassungen**

DNV GL (Det Norske Veritas / Germanischer Lloyd), American Bureau of Shipping, Lloyd's Register, CCS (China Classification Society). Weitere Informationen auf Anfrage.

**Approvals**

DNV GL (Det Norske Veritas / Germanischer Lloyd), American Bureau of Shipping, Lloyd's Register, CCS (China Classification Society). Further information on request.

**Homologaciones**

DNV GL (Det Norske Veritas / Germanischer Lloyd), American Bureau of Shipping, Lloyd's Register, CCS (China Classification Society). Más información bajo demanda.

## Gerade Stutzen

### Straight connectors

### Cuerpos rectos

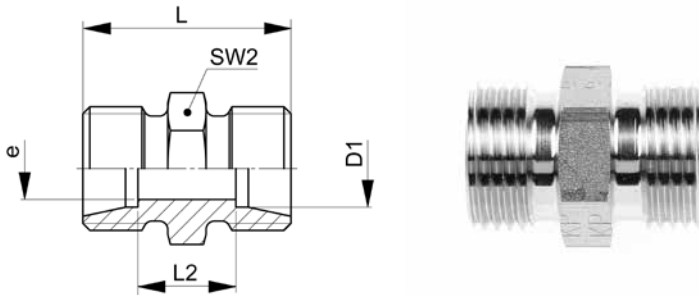

### XGV-..L/S

Type -D1	Mat.-Nr.	PN	L	L2	SW2	e	g/Stk
XGV-04LL	706.1020.040.10	100	20.0	12.0	9	3.0	6
XGV-06LL	706.1020.060.10	100	20.0	9.0	11	4.5	8
XGV-08LL	706.1020.080.10	100	23.0	12.0	12	6.0	12
XGV-06L	706.1020.060.20	500	24.0	10.0	12	4.0	15
XGV-08L	706.1020.080.20	500	25.0	11.0	14	6.0	19
XGV-10L	706.1020.100.20	500	27.0	13.0	17	8.0	26
XGV-12L	706.1020.120.20	400	28.0	14.0	19	10.0	32
XGV-15L	706.1020.150.20	400	30.0	16.0	24	12.0	50
XGV-18L	706.1020.180.20	400	31.0	16.0	27	15.0	74
XGV-22L	706.1020.220.20	250	35.0	20.0	32	19.0	101
XGV-28L	706.1020.280.20	250	36.0	21.0	41	24.0	151
XGV-35L	706.1020.350.20	250	41.0	20.0	46	30.0	225
XGV-42L	706.1020.420.20	250	43.0	21.0	55	36.0	320
XGV-06S	706.1020.060.30	800	30.0	16.0	14	4.0	29
XGV-08S	706.1020.080.30	800	32.0	18.0	17	5.0	41
XGV-10S	706.1020.100.30	800	32.0	17.0	19	7.0	48
XGV-12S	706.1020.120.30	630	34.0	19.0	22	8.0	65
XGV-14S	706.1020.140.30	630	38.0	22.0	24	10.0	83
XGV-16S	706.1020.160.30	630	38.0	21.0	27	12.0	95
XGV-20S	706.1020.200.30	420	44.0	23.0	32	16.0	157
XGV-25S	706.1020.250.30	420	50.0	26.0	41	20.0	271
XGV-30S	706.1020.300.30	420	54.0	27.0	46	25.0	357
XGV-38S	706.1020.380.30	420	61.0	29.0	55	32.0	580

ISO 8434-1-S

**Gerade Verschraubungen**  
**Straight fittings**  
**Racores rectos**

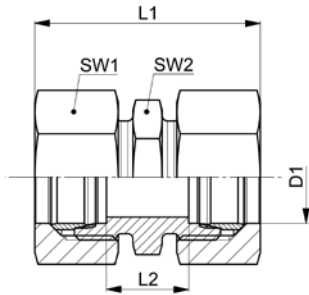

10

**GV-..L/S**

Type -D1	Mat.-Nr.	PN	L1	L2	SW1	SW2	g/Stk
GV-04LL	708.1020.040.10	100	32.0	12.0	10	9	15
GV-06LL	708.1020.060.10	100	32.0	9.0	12	11	20
GV-08LL	708.1020.080.10	100	36.0	12.0	14	12	26
GV-06L	708.1020.060.20	500	40.0	10.0	14	12	35
GV-08L	708.1020.080.20	500	41.0	11.0	17	14	50
GV-10L	708.1020.100.20	500	44.0	13.0	19	17	65
GV-12L	708.1020.120.20	400	45.0	14.0	22	19	85
GV-15L	708.1020.150.20	400	48.0	16.0	27	24	140
GV-18L	708.1020.180.20	400	50.0	16.0	32	27	201
GV-22L	708.1020.220.20	250	54.0	20.0	36	32	274
GV-28L	708.1020.280.20	250	55.0	21.0	41	41	347
GV-35L	708.1020.350.20	250	65.5	20.0	50	46	543
GV-42L	708.1020.420.20	250	68.0	21.0	60	55	790
GV-06S	708.1020.060.30	800	46.0	16.0	17	14	65
GV-08S	708.1020.080.30	800	48.0	18.0	19	17	83
GV-10S	708.1020.100.30	800	51.0	17.0	22	19	110
GV-12S	708.1020.120.30	630	53.0	19.0	24	22	135
GV-14S	708.1020.140.30	630	59.0	22.0	27	24	187
GV-16S	708.1020.160.30	630	60.0	21.0	30	27	229
GV-20S	708.1020.200.30	420	69.0	23.0	36	32	350
GV-25S	708.1020.250.30	420	77.0	26.0	46	41	672
GV-30S	708.1020.300.30	420	83.0	27.0	50	46	821
GV-38S	708.1020.380.30	420	95.0	29.0	60	55	1215

Baumaße sind Ungefährmaße bei angezogener Überwurfmutter.

Sizes are approximate dimensions at tightened nut.

Las medidas son aproximadas con la tuerca de unión apretada.

**ISO 8434-1-SC**

**Winkelstutzen**  
**Elbow connectors**  
**Cuerpos codo**

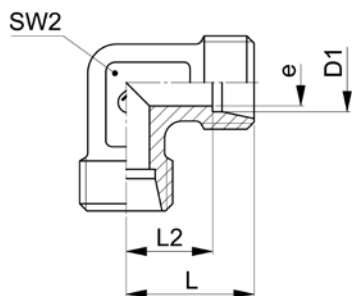

**XWV-..L/S**

Type -D1	Mat.-Nr.	PN	L	L2	SW2	e	g/Stk
XWV-04LL	706.2000.040.10	100	15.0	11.0	9	3.0	9
XWV-06LL	706.2000.060.10	100	15.0	9.5	9	4.5	10
XWV-08LL	706.2000.080.10	100	18.5	13.0	12	6.0	18
XWV-06L	706.2000.060.20	500	19.0	12.0	12	4.0	23
XWV-08L	706.2000.080.20	500	21.0	14.0	12	6.0	26
XWV-10L	706.2000.100.20	500	22.0	15.0	14	8.0	36
XWV-12L	706.2000.120.20	400	24.0	17.0	17	10.0	48
XWV-15L	706.2000.150.20	400	28.0	21.0	19	12.0	83
XWV-18L	706.2000.180.20	400	31.0	23.5	24	15.0	122
XWV-22L	706.2000.220.20	250	35.0	27.5	27	19.0	165
XWV-28L	706.2000.280.20	250	38.0	30.5	36	24.0	265
XWV-35L	706.2000.350.20	250	45.0	34.5	41	30.0	402
XWV-42L	706.2000.420.20	250	51.0	40.0	50	36.0	632
XWV-06S	706.2000.060.30	800	23.0	16.0	12	4.0	37
XWV-08S	706.2000.080.30	800	24.0	17.0	14	5.0	53
XWV-10S	706.2000.100.30	800	25.0	17.5	17	7.0	66
XWV-12S	706.2000.120.30	630	29.0	21.5	17	8.0	89
XWV-14S	706.2000.140.30	630	30.0	22.0	19	10.0	106
XWV-16S	706.2000.160.30	630	33.0	24.5	24	12.0	151
XWV-20S	706.2000.200.30	420	37.0	26.5	27	16.0	218
XWV-25S	706.2000.250.30	420	42.0	30.0	36	20.0	378
XWV-30S	706.2000.300.30	420	49.0	35.5	41	25.0	571
XWV-38S	706.2000.380.30	420	57.0	41.0	50	32.0	911

ISO 8434-1-E

**Winkelverschraubungen**  
**Elbow fittings**  
**Racores codo**

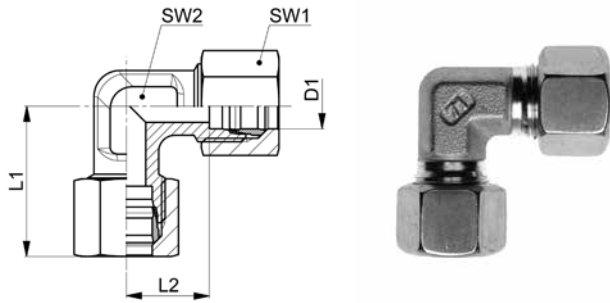

10

**WV-..L/S**

Type -D1	Mat.-Nr.	PN	L1	L2	SW1	SW2	g/Stk
WV-04LL	708.2000.040.10	100	21.0	11.0	10	9	19
WV-06LL	708.2000.060.10	100	21.0	9.5	12	9	24
WV-08LL	708.2000.080.10	100	25.0	13.0	14	12	32
WV-06L	708.2000.060.20	500	27.0	12.0	14	12	42
WV-08L	708.2000.080.20	500	29.0	14.0	17	12	59
WV-10L	708.2000.100.20	500	30.5	15.0	19	14	74
WV-12L	708.2000.120.20	400	32.5	17.0	22	17	103
WV-15L	708.2000.150.20	400	37.0	21.0	27	19	169
WV-18L	708.2000.180.20	400	40.5	23.5	32	24	248
WV-22L	708.2000.220.20	250	44.5	27.5	36	27	320
WV-28L	708.2000.280.20	250	47.5	30.5	41	36	454
WV-35L	708.2000.350.20	250	57.0	34.5	50	41	675
WV-42L	708.2000.420.20	250	63.5	40.0	60	50	1070
WV-06S	708.2000.060.30	800	31.0	16.0	17	12	74
WV-08S	708.2000.080.30	800	32.0	17.0	19	14	95
WV-10S	708.2000.100.30	800	34.5	17.5	22	17	128
WV-12S	708.2000.120.30	630	38.5	21.5	24	17	159
WV-14S	708.2000.140.30	630	40.5	22.0	27	19	210
WV-16S	708.2000.160.30	630	44.0	24.5	30	24	260
WV-20S	708.2000.200.30	420	49.5	26.5	36	27	410
WV-25S	708.2000.250.30	420	55.5	30.0	46	36	776
WV-30S	708.2000.300.30	420	63.5	35.5	50	41	1003
WV-38S	708.2000.380.30	420	74.0	41.0	60	50	1535

Baumaße sind Ungefährmaße bei angezogener Überwurfmutter.

Sizes are approximate dimensions at tightened nut.

Las medidas son aproximadas con la tuerca de unión apretada.

**ISO 8434-1-EC**

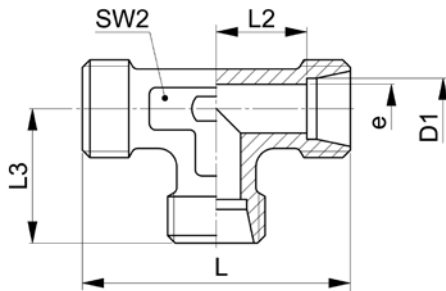
**T-Stutzen**
**T connectors**
**Cuerpos T**

**XTV-..L/S**

Type -D1	Mat.-Nr.	PN	L	L2	L3	SW2	e	g/Stk
XTV-04LL	706.3000.040.10	100	30.0	11.0	15.0	9	3.0	13
XTV-06LL	706.3000.060.10	100	30.0	9.5	15.0	9	4.0	14
XTV-08LL	706.3000.080.10	100	34.0	11.5	17.0	12	6.0	22
XTV-06L	706.3000.060.20	500	38.0	12.0	19.0	12	4.0	32
XTV-08L	706.3000.080.20	500	42.0	14.0	21.0	12	6.0	37
XTV-10L	706.3000.100.20	500	44.0	15.0	22.0	14	8.0	47
XTV-12L	706.3000.120.20	400	48.0	17.0	24.0	17	10.0	63
XTV-15L	706.3000.150.20	400	56.0	21.0	28.0	19	12.0	111
XTV-18L	706.3000.180.20	400	62.0	23.5	31.0	24	15.0	160
XTV-22L	706.3000.220.20	250	70.0	27.5	35.0	27	19.0	222
XTV-28L	706.3000.280.20	250	76.0	30.5	38.0	36	24.0	359
XTV-35L	706.3000.350.20	250	90.0	34.5	45.0	41	30.0	534
XTV-42L	706.3000.420.20	250	102.0	40.0	51.0	50	36.0	806
XTV-06S	706.3000.060.30	800	46.0	16.0	23.0	12	4.0	53
XTV-08S	706.3000.080.30	800	48.0	17.0	24.0	14	5.0	71
XTV-10S	706.3000.100.30	800	50.0	17.5	25.0	17	7.0	88
XTV-12S	706.3000.120.30	630	58.0	21.5	29.0	17	8.0	121
XTV-14S	706.3000.140.30	630	60.0	22.0	30.0	19	10.0	143
XTV-16S	706.3000.160.30	630	66.0	24.5	33.0	24	12.0	197
XTV-20S	706.3000.200.30	420	74.0	26.5	37.0	27	16.0	294
XTV-25S	706.3000.250.30	420	84.0	30.0	42.0	36	20.0	512
XTV-30S	706.3000.300.30	420	98.0	35.5	49.0	41	25.0	765
XTV-38S	706.3000.380.30	420	114.0	41.0	57.0	50	32.0	1188

ISO 8434-1-T

**T-Verschraubungen**

**T fittings**

**Racores T**

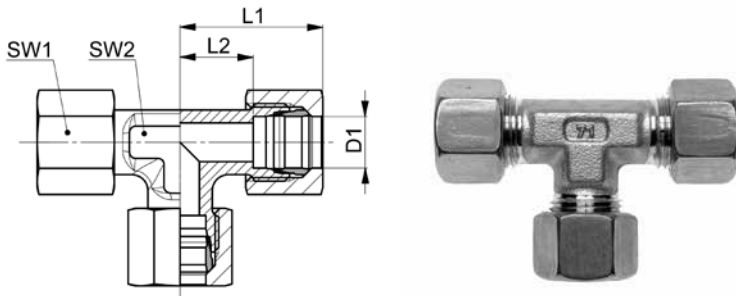

10

**TV-..L/S**

Type -D1	Mat.-Nr.	PN	L1	L2	SW1	SW2	g/Stk
TV-04LL	708.3000.040.10	100	21.0	11.0	10	9	27
TV-06LL	708.3000.060.10	100	21.0	9.5	12	9	34
TV-08LL	708.3000.080.10	100	23.5	11.5	14	12	39
TV-06L	708.3000.060.20	500	27.0	12.0	14	12	51
TV-08L	708.3000.080.20	500	29.0	14.0	17	12	85
TV-10L	708.3000.100.20	500	30.5	15.0	19	14	106
TV-12L	708.3000.120.20	400	32.5	17.0	22	17	140
TV-15L	708.3000.150.20	400	37.0	21.0	27	19	240
TV-18L	708.3000.180.20	400	40.5	23.5	32	24	348
TV-22L	708.3000.220.20	250	44.5	27.5	36	27	468
TV-28L	708.3000.280.20	250	47.5	30.5	41	36	665
TV-35L	708.3000.350.20	250	57.0	34.5	50	41	1025
TV-42L	708.3000.420.20	250	63.5	40.0	60	50	1500
TV-06S	708.3000.060.30	800	31.0	16.0	17	12	110
TV-08S	708.3000.080.30	800	32.0	17.0	19	14	134
TV-10S	708.3000.100.30	800	34.5	17.5	22	17	190
TV-12S	708.3000.120.30	630	38.5	21.5	24	17	227
TV-14S	708.3000.140.30	630	40.5	22.0	27	19	300
TV-16S	708.3000.160.30	630	44.0	24.5	30	24	390
TV-20S	708.3000.200.30	420	49.5	26.5	36	27	590
TV-25S	708.3000.250.30	420	55.5	30.0	46	36	1180
TV-30S	708.3000.300.30	420	63.5	35.5	50	41	1430
TV-38S	708.3000.380.30	420	74.0	41.0	60	50	2010

Baumaße sind Ungefährmaße bei angezogener Überwurfmutter.

Sizes are approximate dimensions at tightened nut.

Las medidas son aproximadas con la tuerca de unión apretada.

**ISO 8434-1-TC**

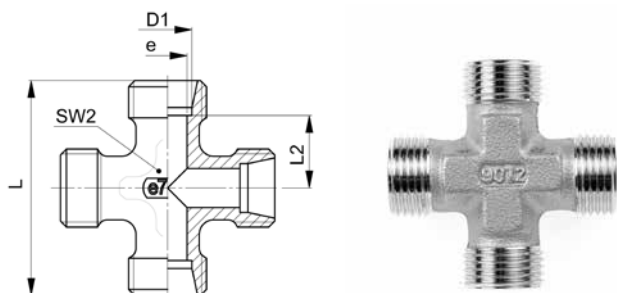
**Kreuz-Stutzen**
**Cross connectors**
**Cuerpos en cruz**

**XKV-..L/S**

Type -D1	Mat.-Nr.	PN	L	L2	SW2	e	g/Stk
XKV-06L	706.4000.060.20	500	38.0	12.0	12	4.0	40
XKV-08L	706.4000.080.20	500	42.0	14.0	12	6.0	51
XKV-10L	706.4000.100.20	500	44.0	15.0	14	8.0	59
XKV-12L	706.4000.120.20	400	48.0	17.0	17	10.0	80
XKV-15L	706.4000.150.20	400	56.0	21.0	19	12.0	133
XKV-18L	706.4000.180.20	400	62.0	23.5	24	15.0	220
XKV-22L	706.4000.220.20	250	70.0	27.5	27	19.0	261
XKV-28L	706.4000.280.20	250	76.0	30.5	36	24.0	425
XKV-35L	706.4000.350.20	250	90.0	34.5	41	30.0	699
XKV-42L	706.4000.420.20	250	102.0	40.0	50	36.0	959
XKV-06S	706.4000.060.30	800	46.0	16.0	12	4.0	72
XKV-08S	706.4000.080.30	800	48.0	17.0	14	5.0	91
XKV-10S	706.4000.100.30	800	50.0	17.5	17	7.0	112
XKV-12S	706.4000.120.30	630	58.0	21.5	17	8.0	150
XKV-14S	706.4000.140.30	630	60.0	22.0	19	10.0	174
XKV-16S	706.4000.160.30	630	66.0	24.5	24	12.0	267
XKV-20S	706.4000.200.30	420	74.0	26.5	27	16.0	352
XKV-25S	706.4000.250.30	420	84.0	30.0	36	20.0	618
XKV-30S	706.4000.300.30	420	98.0	35.5	41	25.0	965
XKV-38S	706.4000.380.30	420	114.0	41.0	50	32.0	1444

**ISO 8434-1-K**

**Kreuz-Verschraubungen**

**Cross fittings**

**Racores en cruz**

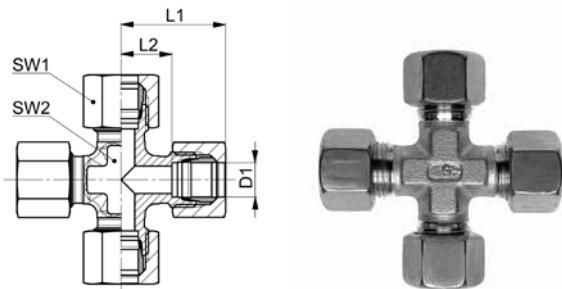

10

**KV-..L/S**

Type -D1	Mat.-Nr.	PN	L1	L2	SW1	SW2	g/Stk
KV-06L	708.4000.060.20	500	27.0	12.0	14	12	80
KV-08L	708.4000.080.20	500	29.0	14.0	17	12	109
KV-10L	708.4000.100.20	500	30.0	15.0	19	14	158
KV-12L	708.4000.120.20	400	32.0	17.0	22	17	185
KV-15L	708.4000.150.20	400	36.0	21.0	27	19	338
KV-18L	708.4000.180.20	400	40.0	23.5	32	24	445
KV-22L	708.4000.220.20	250	44.0	27.5	36	27	600
KV-28L	708.4000.280.20	250	47.0	30.5	41	36	810
KV-35L	708.4000.350.20	250	56.0	34.5	50	41	1250
KV-42L	708.4000.420.20	250	63.5	40.0	60	50	1880
KV-06S	708.4000.060.30	800	31.0	16.0	17	12	140
KV-08S	708.4000.080.30	800	32.0	17.0	19	14	175
KV-10S	708.4000.100.30	800	34.0	17.5	22	17	235
KV-12S	708.4000.120.30	630	38.0	21.5	24	17	315
KV-14S	708.4000.140.30	630	40.0	22.0	27	19	385
KV-16S	708.4000.160.30	630	43.0	24.5	30	24	500
KV-20S	708.4000.200.30	420	48.0	26.5	36	27	857
KV-25S	708.4000.250.30	420	54.0	30.0	46	36	1250
KV-30S	708.4000.300.30	420	62.0	35.5	50	41	1540
KV-38S	708.4000.380.30	420	72.0	41.0	60	50	2900

Baumaße sind Ungefährmaße bei angezogener Überwurfmutter.

Sizes are approximate dimensions at tightened nut.

Las medidas son aproximadas con la tuerca de unión apretada.

**ISO 8434-1-KC**

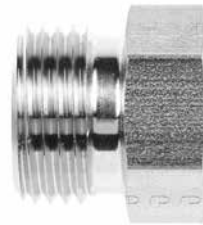
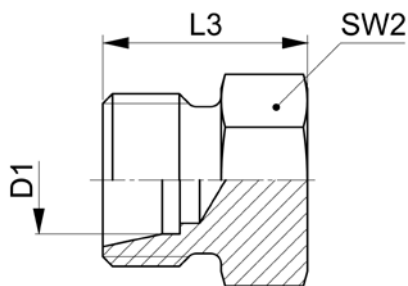
**Verschlussstutzen**
**Caps**
**Cuerpos de cierre**

**XVSA-..L/S**

Type-D1	Mat.-Nr.	PN	L3	SW2	g/Stk
XVSA-06L	706.1205.060.20	500	16.0	12	11
XVSA-08L	706.1205.080.20	500	18.0	14	14
XVSA-10L	706.1205.100.20	500	19.0	17	25
XVSA-12L	706.1205.120.20	500	19.0	19	30
XVSA-15L	706.1205.150.20	500	22.0	24	59
XVSA-18L	706.1205.180.20	500	22.0	27	75
XVSA-22L	706.1205.220.20	250	26.0	32	122
XVSA-28L	706.1205.280.20	250	26.0	41	187
XVSA-35L	706.1205.350.20	250	30.0	46	278
XVSA-42L	706.1205.420.20	250	30.0	55	366
XVSA-06S	706.1205.060.30	800	18.0	14	19
XVSA-08S	706.1205.080.30	800	20.0	17	29
XVSA-10S	706.1205.100.30	800	20.0	19	35
XVSA-12S	706.1205.120.30	630	20.0	22	45
XVSA-14S	706.1205.140.30	630	24.0	24	66
XVSA-16S	706.1205.160.30	630	24.0	27	79
XVSA-20S	706.1205.200.30	420	28.0	32	132
XVSA-25S	706.1205.250.30	420	30.0	41	213
XVSA-30S	706.1205.300.30	420	34.0	46	312
XVSA-38S	706.1205.380.30	420	36.0	55	456

**Verschlussverschraubungen**

**Caps**

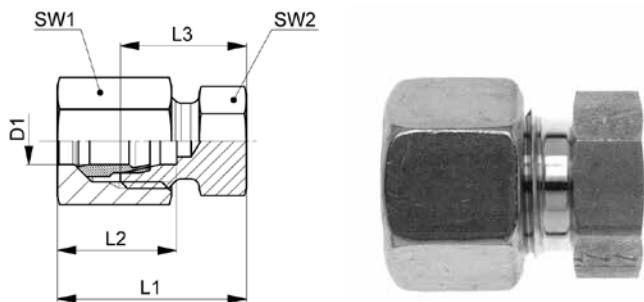
**Racores de cierre**



**VSA-..L/S**

Type -D1	Mat.-Nr.	PN	L1	L2	L3	SW1	SW2	g/Stk
VSA-06L	708.1205.060.20	500	24.0	15.0	16.0	14	12	22
VSA-08L	708.1205.080.20	500	26.0	15.0	18.0	17	14	30
VSA-10L	708.1205.100.20	500	27.5	15.5	19.0	19	17	38
VSA-12L	708.1205.120.20	500	27.5	15.5	19.0	22	19	50
VSA-15L	708.1205.150.20	500	31.0	16.0	22.0	27	24	84
VSA-18L	708.1205.180.20	500	31.5	17.0	22.0	32	27	124
VSA-22L	708.1205.220.20	250	35.5	17.0	26.0	36	32	166
VSA-28L	708.1205.280.20	250	35.5	17.0	26.0	41	41	238
VSA-35L	708.1205.350.20	250	42.0	22.5	30.0	50	46	356
VSA-42L	708.1205.420.20	250	42.5	23.5	30.0	60	55	556
VSA-06S	708.1205.060.30	800	26.0	15.0	18.0	17	14	36
VSA-08S	708.1205.080.30	800	28.0	15.0	20.0	19	17	42
VSA-10S	708.1205.100.30	800	29.5	17.0	20.0	22	19	64
VSA-12S	708.1205.120.30	630	29.5	17.0	20.0	24	22	78
VSA-14S	708.1205.140.30	630	34.5	18.5	24.0	27	24	118
VSA-16S	708.1205.160.30	630	35.0	19.5	24.0	30	27	142
VSA-20S	708.1205.200.30	420	40.5	23.0	28.0	36	32	236
VSA-25S	708.1205.250.30	420	43.5	25.5	30.0	46	41	448
VSA-30S	708.1205.300.30	420	48.5	28.0	34.0	50	46	540
VSA-38S	708.1205.380.30	420	53.0	33.0	36.0	60	55	870

Baumaße sind Ungefährmaße bei angezogener Überwurfmutter.

Sizes are approximate dimensions at tightened nut.

Las medidas son aproximadas con la tuerca de unión apretada.

**Gerade Zwischenstutzen mit Dichtkegel und O-Ring**  
**Straight unions with taper and O-ring**  
**Racores de unión rectos con junta cónica y junta tórica**

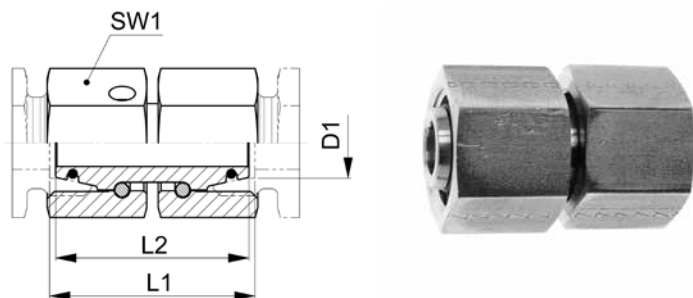

**VKO-..L/S**

Type -D1	Mat.-Nr.	PN	L1	L2	SW1	g/Stk
VKO-06L	708.1070.060.21	315	33.0	32.0	17	48
VKO-08L	708.1070.080.21	315	33.0	32.0	17	42
VKO-10L	708.1070.100.21	315	34.0	33.0	19	56
VKO-12L	708.1070.120.21	315	34.0	33.0	22	78
VKO-15L	708.1070.150.21	315	39.0	38.0	27	128
VKO-18L	708.1070.180.21	315	38.0	36.0	32	182
VKO-22L	708.1070.220.21	160	44.0	42.0	36	254
VKO-28L	708.1070.280.21	160	48.0	46.0	46	440
VKO-35L	708.1070.350.21	160	52.0	48.0	50	486
VKO-42L	708.1070.420.21	160	57.0	52.0	60	712
VKO-06S	708.1070.060.31	630	33.0	32.0	17	44
VKO-08S	708.1070.080.31	630	34.0	33.0	19	60
VKO-10S	708.1070.100.31	630	35.0	33.0	22	84
VKO-12S	708.1070.120.31	630	38.0	36.0	24	110
VKO-14S	708.1070.140.31	630	41.0	39.0	27	142
VKO-16S	708.1070.160.31	400	42.0	39.0	30	182
VKO-20S	708.1070.200.31	400	48.0	44.0	36	300
VKO-25S	708.1070.250.31	400	53.0	46.0	46	481
VKO-30S	708.1070.300.31	400	62.0	52.0	50	646
VKO-38S	708.1070.380.31	315	67.0	52.0	60	936

Baumaße sind Ungefährmaße bei angezogener Überwurfmutter.

Sizes are approximate dimensions at tightened nut.

Las medidas son aproximadas con la tuerca de unión apretada.

Dichtungsmaterial: FKM

Sealing material: FKM

Material de junta tórica: FKM.

**Gerade Schottstutzen**

mit Kontermutter

**Bulkhead connectors**

with counter nut

**Cuerpos pasatabiques rectos**

con contratuerca

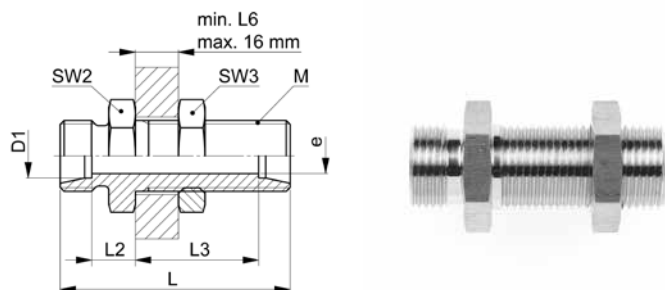

**XGSV-..L/S KM**

Type-D1	Mat.-Nr.	PN	M	L	L2	L3	SW2	SW3	e	g/Stk
M=metrisches Gewinde (zylindrisch)		M=metric thread (parallel)								
							M=rosca métrica (cilíndrica)			
XGSV-06L KM	707.1501.060.20	500	12x1.5	48.0	7.0	27.0	17	17	4.0	46
XGSV-08L KM	707.1501.080.20	500	14x1.5	49.0	8.0	27.0	19	19	6.0	59
XGSV-10L KM	707.1501.100.20	500	16x1.5	52.0	10.0	28.0	22	22	8.0	78
XGSV-12L KM	707.1501.120.20	400	18x1.5	53.0	10.0	29.0	24	24	10.0	91
XGSV-15L KM	707.1501.150.20	400	22x1.5	57.0	12.0	31.0	27	30	12.0	147
XGSV-18L KM	707.1501.180.20	400	26x1.5	61.0	13.5	32.5	32	36	15.0	222
XGSV-22L KM	707.1501.220.20	250	30x2.0	66.0	16.5	34.5	36	41	19.0	286
XGSV-28L KM	707.1501.280.20	250	36x2.0	69.0	18.5	35.5	41	46	24.0	384
XGSV-35L KM	707.1501.350.20	250	45x2.0	76.0	18.5	36.5	50	55	30.0	609
XGSV-42L KM	707.1501.420.20	250	52x2.0	77.0	19.0	36.0	60	65	36.0	827
XGSV-06S KM	707.1501.060.30	800	14x1.5	55.0	12.0	29.0	19	19	4.0	75
XGSV-08S KM	707.1501.080.30	800	16x1.5	56.0	13.0	29.0	22	22	5.0	100
XGSV-10S KM	707.1501.100.30	800	18x1.5	59.0	14.5	29.5	24	24	7.0	125
XGSV-12S KM	707.1501.120.30	630	20x1.5	60.0	14.5	30.5	27	27	8.0	159
XGSV-14S KM	707.1501.140.30	630	22x1.5	65.0	17.0	32.0	30	30	10.0	200
XGSV-16S KM	707.1501.160.30	630	24x1.5	65.0	16.5	31.5	32	32	12.0	222
XGSV-20S KM	707.1501.200.30	420	30x2.0	72.0	17.5	33.5	41	41	16.0	382
XGSV-25S KM	707.1501.250.30	420	36x2.0	79.0	20.0	35.0	46	46	20.0	548
XGSV-30S KM	707.1501.300.30	420	42x2.0	86.0	21.5	37.5	50	50	25.0	703
XGSV-38S KM	707.1501.380.30	420	52x2.0	91.0	22.0	37.0	65	65	32.0	1169

für D1 ≤ 18 mm L6 = 3 mm  
für D1 > 18 mm L6 = 4 mm

for D1 ≤ 18 mm L6 = 3 mm  
for D1 > 18 mm L6 = 4 mm

para D1 ≤ 18 mm L6 = 3 mm  
para D1 > 18 mm L6 = 4 mm

**ISO 8434-1-BHS+LN**

**Gerade Schottverschraubungen**  
**Bulkhead fittings**  
**Racores pasatabiques rectos**

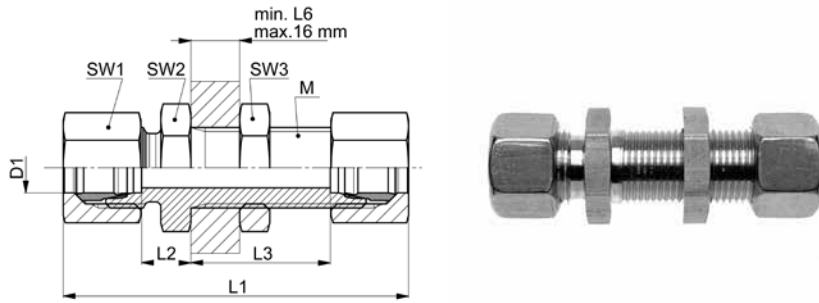

10

**GSV-..L/S**

Type-D1	Mat.-Nr.	PN	M	L1	L2	L3	SW1	SW2	SW3	g/Stk
M=metrisches Gewinde (zylindrisch)		M=metric thread (parallel)			M=rosca métrica (cilindrica)					
GSV-06L	708.1500.060.20	500	12x1.5	64.0	7.0	27.0	14	17	17	72
GSV-08L	708.1500.080.20	500	14x1.5	65.0	8.0	27.0	17	19	19	83
GSV-10L	708.1500.100.20	500	16x1.5	68.0	10.0	28.0	19	22	22	125
GSV-12L	708.1500.120.20	400	18x1.5	69.0	10.0	29.0	22	24	24	135
GSV-15L	708.1500.150.20	400	22x1.5	73.0	12.0	31.0	27	27	30	230
GSV-18L	708.1500.180.20	400	26x1.5	79.0	13.5	32.5	32	32	36	345
GSV-22L	708.1500.220.20	250	30x2.0	84.0	16.5	34.5	36	36	41	435
GSV-28L	708.1500.280.20	250	36x2.0	90.0	18.5	35.5	41	41	46	545
GSV-35L	708.1500.350.20	250	45x2.0	100.0	18.5	36.5	50	50	55	874
GSV-42L	708.1500.420.20	250	52x2.0	101.0	19.0	36.0	60	60	65	1365
GSV-06S	708.1500.060.30	800	14x1.5	71.0	12.0	29.0	17	19	19	112
GSV-08S	708.1500.080.30	800	16x1.5	72.0	13.0	29.0	19	22	22	132
GSV-10S	708.1500.100.30	800	18x1.5	77.0	14.5	29.5	22	24	24	170
GSV-12S	708.1500.120.30	630	20x1.5	78.0	14.5	30.5	24	27	27	215
GSV-14S	708.1500.140.30	630	22x1.5	85.0	17.0	32.0	27	30	30	322
GSV-16S	708.1500.160.30	630	24x1.5	85.0	16.5	31.5	30	32	32	345
GSV-20S	708.1500.200.30	420	30x2.0	97.0	17.5	33.5	36	41	41	575
GSV-25S	708.1500.250.30	420	36x2.0	106.0	20.0	35.0	46	46	46	949
GSV-30S	708.1500.300.30	420	42x2.0	115.0	21.5	37.5	50	50	50	1120
GSV-38S	708.1500.380.30	420	52x2.0	123.0	22.0	37.0	60	65	65	1445

Baumaße sind Ungefährmaße bei angezogener Überwurfmutter.

Sizes are approximate dimensions at tightened nut.

Las medidas son aproximadas con la tuerca de unión apretada.

für D1 ≤ 18 mm L6 = 3 mm  
 für D1 > 18 mm L6 = 4 mm

for D1 ≤ 18 mm L6 = 3 mm  
 for D1 > 18 mm L6 = 4 mm

para D1 ≤ 18 mm L6 = 3 mm  
 para D1 > 18 mm L6 = 4 mm

**ISO 8434-1-BHSC+LN**

## Winkel-Schottverschraubungsstutzen

mit Kontermutter

## Bulkhead elbow connectors

with counter nut

## Cuerpos pasatabiques a codo

con contratuerca

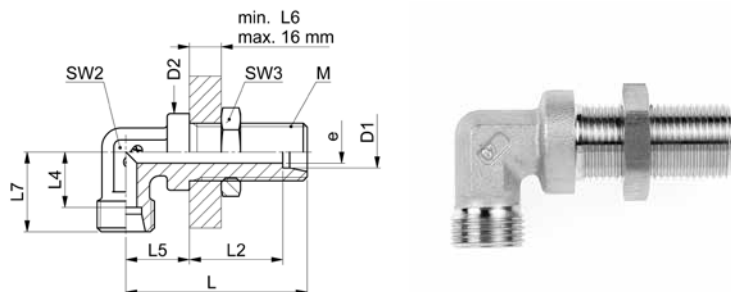

### XWSV-..L/S KM

Type-D1	Mat.-Nr.	PN	D2	M	L	L2	L4	L5	L7	SW2	SW3	e	g/Stk
M=metrisches Gewinde (zylindrisch)	M=metric thread (parallel)	M=rosca métrica (cilíndrica)											
XWSV-06L KM	707.2700.060.20	500	17.0	12x1.5	48.0	27.0	12.0	14.0	19.0	12	17	4.0	50
XWSV-08L KM	707.2700.080.20	500	19.0	14x1.5	51.0	27.0	14.0	17.0	21.0	12	19	6.0	63
XWSV-10L KM	707.2700.100.20	500	22.0	16x1.5	53.0	28.0	15.0	18.0	22.0	14	22	8.0	80
XWSV-12L KM	707.2700.120.20	400	24.0	18x1.5	56.0	29.0	17.0	20.0	24.0	17	24	10.0	104
XWSV-15L KM	707.2700.150.20	400	28.0	22x1.5	61.0	31.0	21.0	23.0	28.0	19	30	12.0	161
XWSV-18L KM	707.2700.180.20	400	32.0	26x1.5	64.0	32.5	23.5	24.0	31.0	24	36	15.0	232
XWSV-22L KM	707.2700.220.20	250	36.0	30x2.0	72.0	34.5	27.5	30.0	35.0	27	41	19.0	304
XWSV-28L KM	707.2700.280.20	250	42.0	36x2.0	77.0	35.5	30.5	34.0	38.0	36	46	24.0	469
XWSV-35L KM	707.2700.350.20	250	50.0	45x2.0	86.0	36.5	34.5	39.0	45.0	41	55	30.0	709
XWSV-42L KM	707.2700.420.20	250	60.0	52x2.0	90.0	36.0	40.0	43.0	51.0	50	65	36.0	1140
XWSV-06S KM	707.2700.060.30	800	19.0	14x1.5	53.0	29.0	16.0	17.0	23.0	12	19	4.0	78
XWSV-08S KM	707.2700.080.30	800	22.0	16x1.5	54.0	29.0	17.0	18.0	24.0	14	22	5.0	103
XWSV-10S KM	707.2700.100.30	800	24.0	18x1.5	57.0	29.5	17.5	20.0	25.0	17	24	7.0	132
XWSV-12S KM	707.2700.120.30	630	27.0	20x1.5	59.0	30.5	21.5	21.0	29.0	17	27	8.0	168
XWSV-14S KM	707.2700.140.30	630	28.0	22x1.5	63.0	32.0	22.0	23.0	30.0	19	30	10.0	192
XWSV-16S KM	707.2700.160.30	630	32.0	24x1.5	64.0	31.5	24.5	24.0	33.0	24	32	12.0	252
XWSV-20S KM	707.2700.200.30	420	36.0	30x2.0	74.0	33.5	26.5	30.0	37.0	27	41	16.0	380
XWSV-25S KM	707.2700.250.30	420	42.0	36x2.0	81.0	35.0	30.0	34.0	42.0	36	46	20.0	623
XWSV-30S KM	707.2700.300.30	420	50.0	42x2.0	90.0	37.5	35.5	39.0	49.0	41	50	25.0	891
XWSV-38S KM	707.2700.380.30	420	60.0	52x2.0	96.0	37.0	41.0	43.0	57.0	50	65	32.0	1483

für D1 ≤ 18 mm L6 = 3 mm  
für D1 > 18 mm L6 = 4 mm

for D1 ≤ 18 mm L6 = 3 mm  
for D1 > 18 mm L6 = 4 mm

para D1 ≤ 18 mm L6 = 3 mm  
para D1 > 18 mm L6 = 4 mm

**ISO 8434-1-BHE+LN**

**Winkel-Schottverschraubungen**

**Bulkhead elbow fittings**

**Racores pasatabiques a codo**

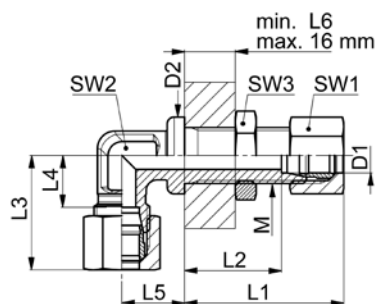

10

**WSV-..L/S**

Type -D1	Mat.-Nr.	PN	D2	M	L1	L2	L3	L4	L5	SW1	SW2	SW3	g/Stk
M=metrisches Gewinde (zylindrisch)		M=metric thread (parallel)			M=rosca métrica (cilindrica)								
WSV-06L	708.2700.060.20	500	17.0	12x1.5	42.0	27.0	27.0	12.0	14.0	14	12	17	73
WSV-08L	708.2700.080.20	500	19.0	14x1.5	42.0	27.0	29.0	14.0	17.0	17	12	19	92
WSV-10L	708.2700.100.20	500	22.0	16x1.5	43.5	28.0	30.5	15.0	18.0	19	14	22	172
WSV-12L	708.2700.120.20	400	24.0	18x1.5	44.5	29.0	32.5	17.0	20.0	22	17	24	215
WSV-15L	708.2700.150.20	400	28.0	22x1.5	47.0	31.0	37.0	21.0	23.0	27	19	30	345
WSV-18L	708.2700.180.20	400	32.0	26x1.5	49.5	32.5	40.5	23.5	24.0	32	24	36	380
WSV-22L	708.2700.220.20	250	36.0	30x2.0	51.5	34.5	44.5	27.5	30.0	36	27	41	490
WSV-28L	708.2700.280.20	250	42.0	36x2.0	52.5	35.5	47.5	30.5	34.0	41	36	46	678
WSV-35L	708.2700.350.20	250	50.0	45x2.0	59.0	36.5	57.0	34.5	39.0	50	41	55	1055
WSV-42L	708.2700.420.20	250	60.0	52x2.0	59.5	36.0	63.5	40.0	43.0	60	50	65	1583
WSV-06S	708.2700.060.30	800	19.0	14x1.5	44.0	29.0	31.0	16.0	17.0	17	12	19	117
WSV-08S	708.2700.080.30	800	22.0	16x1.5	44.0	29.0	32.5	17.0	18.0	19	14	22	185
WSV-10S	708.2700.100.30	800	24.0	18x1.5	46.5	29.5	34.5	17.5	20.0	22	17	24	195
WSV-12S	708.2700.120.30	630	27.0	20x1.5	47.5	30.0	38.5	21.5	21.0	24	17	27	245
WSV-14S	708.2700.140.30	630	28.0	22x1.5	50.5	32.0	40.5	22.0	23.0	27	19	30	375
WSV-16S	708.2700.160.30	630	32.0	24x1.5	51.0	31.5	44.0	24.5	24.0	30	24	32	395
WSV-20S	708.2700.200.30	420	36.0	30x2.0	56.5	33.5	49.5	26.5	30.0	36	27	41	606
WSV-25S	708.2700.250.30	420	42.0	36x2.0	60.5	35.0	55.5	30.0	34.0	46	36	46	1050
WSV-30S	708.2700.300.30	420	50.0	42x2.0	65.5	37.5	63.5	35.5	39.0	50	41	50	1360
WSV-38S	708.2700.380.30	420	60.0	52x2.0	70.0	37.0	74.0	41.0	43.0	60	50	65	2060

Baumaße sind Ungefährmaße bei angezogener Überwurfmutter.

Sizes are approximate dimensions at tightened nut.

Las medidas son aproximadas con la tuerca de unión apretada.

für D1 ≤ 18 mm L6 = 3 mm  
für D1 > 18 mm L6 = 4 mm

for D1 ≤ 18 mm L6 = 3 mm  
for D1 > 18 mm L6 = 4 mm

para D1 ≤ 18 mm L6 = 3 mm  
para D1 > 18 mm L6 = 4 mm

**ISO 8434-1-BHEC+LN**

**Gerade Einschraubstutzen**

Abdichtung durch Dichtkante Form B nach DIN 3852-2

**Straight male adaptor connectors**

sealing edge form B acc. DIN 3852-2

**Cuerpos para roscar rectos**

cierre hermético mediante borde de obturación forma B según DIN 3852-2

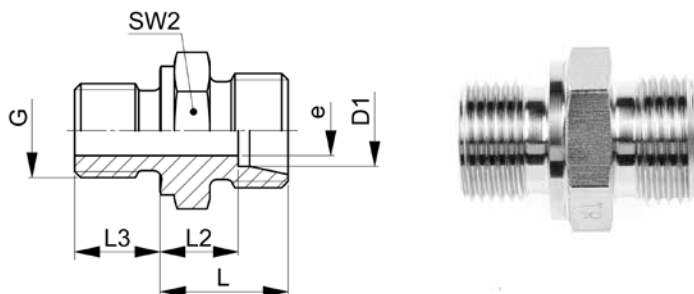

**XGEV-..LR**

Type-D1 G	Mat.-Nr.	PN	G	L	L2	L3	SW2	e	g/Stk
G=Rohrgewinde (zylindrisch)		G=BSP thread (parallel)			G=rosca de conexión (cilíndrica)				
● XGEV-04LLR 1.8	706.1141.060.10	100	1/8	13.5	9.5	8.0	14	3.0	10
● XGEV-06LLR 1.8	706.1141.100.10	100	1/8	13.5	8.0	8.0	14	4.5	10
● XGEV-08LLR 1.8	706.1141.160.10	100	1/8	14.5	9.0	8.0	14	4.5	12
● XGEV-06LR 1.8	706.1141.100.20	500	1/8	15.5	8.5	8.0	14	4.0	14
XGEV-06LR 1.4	706.1141.110.20	500	1/4	17.0	10.0	12.0	19	4.0	29
XGEV-06LR 3.8	706.1141.120.20	500	3/8	18.5	11.5	12.0	22	4.0	47
XGEV-06LR 1.2	706.1141.125.20	500	1/2	20.0	13.0	14.0	27	4.0	81
XGEV-08LR 1.8	706.1141.160.20	500	1/8	15.5	8.5	8.0	14	4.0	16
● XGEV-08LR 1.4	706.1141.170.20	500	1/4	17.0	10.0	12.0	19	6.0	28
XGEV-08LR 3.8	706.1141.180.20	500	3/8	19.5	12.5	12.0	22	6.0	49
XGEV-08LR 1.2	706.1141.185.20	500	1/2	20.0	13.0	14.0	27	6.0	79
XGEV-10LR 1.8	706.1141.265.20	500	1/8	17.5	10.5	8.0	17	4.0	22
● XGEV-10LR 1.4	706.1141.270.20	500	1/4	18.0	11.0	12.0	19	7.0	29
XGEV-10LR 3.8	706.1141.280.20	500	3/8	19.5	12.5	12.0	22	8.0	44
XGEV-10LR 1.2	706.1141.285.20	500	1/2	21.0	14.0	14.0	27	8.0	77
XGEV-12LR 1.8	706.1141.375.20	400	1/8	18.5	11.5	8.0	19	4.0	30
XGEV-12LR 1.4	706.1141.380.20	400	1/4	19.0	12.0	12.0	19	7.0	33
● XGEV-12LR 3.8	706.1141.390.20	400	3/8	19.5	12.5	12.0	22	9.0	43
XGEV-12LR 1.2	706.1141.400.20	400	1/2	20.0	13.0	14.0	27	9.0	71
XGEV-12LR 3.4	706.1141.405.20	400	3/4	21.0	14.0	16.0	32	9.0	125
XGEV-15LR 1.4	706.1141.528.20	400	1/4	20.0	13.0	12.0	24	7.0	51
XGEV-15LR 3.8	706.1141.532.20	400	3/8	20.5	13.5	12.0	24	9.0	56
● XGEV-15LR 1.2	706.1141.534.20	400	1/2	21.0	14.0	14.0	27	11.0	73
XGEV-15LR 3.4	706.1141.536.20	400	3/4	22.0	15.0	16.0	32	11.0	125
XGEV-18LR 3.8	706.1141.644.20	400	3/8	22.0	14.5	12.0	27	9.0	77
● XGEV-18LR 1.2	706.1141.646.20	400	1/2	22.0	14.5	14.0	27	14.0	72
XGEV-18LR 3.4	706.1141.648.20	400	3/4	22.0	14.5	16.0	32	14.0	119
XGEV-22LR 3.8	706.1141.763.20	250	3/8	23.5	16.0	12.0	32	9.0	104
XGEV-22LR 1.2	706.1141.764.20	250	1/2	24.0	16.5	14.0	32	14.0	99
● XGEV-22LR 3.4	706.1141.768.20	250	3/4	24.0	16.5	16.0	32	18.0	106
XGEV-22LR 1.1	706.1141.770.20	250	1	25.0	17.5	18.0	41	18.0	199
XGEV-22LR 5.4	706.1141.771.20	250	1 1/4	26.0	18.5	20.0	50	18.0	292

Fortsetzung auf nächster linker Seite

To be continued on next left page

Continuación próxima página izquierda

## Gerade Einschraubverschraubungen

Abdichtung durch Dichtkante Form B nach DIN 3852-2

## Straight male adaptor fittings

sealing edge form B acc. DIN 3852-2

## Racores para roscar rectos

cierre hermético mediante borde de obturación forma B según DIN 3852-2

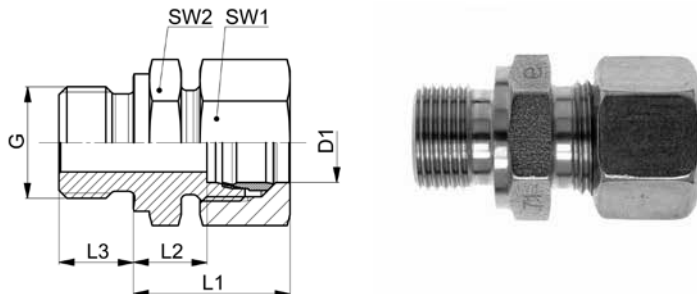

10

### GEV-..LR

Type-D1 G	Mat.-Nr.	PN	G	L1	L2	L3	SW1	SW2	g/Stk
G=Rohrgewinde (zylindrisch)		G=BSP thread (parallel)			G=rosca de conexión (cilíndrica)				
● GEV-04LLR 1.8	708.1141.060.10	100	1/8	19.5	9.5	8.0	10	14	15
● GEV-06LLR 1.8	708.1141.100.10	100	1/8	19.5	8.0	8.0	12	14	19
● GEV-08LLR 1.8	708.1141.160.10	100	1/8	20.5	9.0	8.0	14	14	20
● GEV-06LR 1.8	708.1141.100.20	500	1/8	23.5	8.5	8.0	14	14	25
GEV-06LR 1.4	708.1141.110.20	500	1/4	25.0	10.0	12.0	14	19	40
GEV-06LR 3.8	708.1141.120.20	500	3/8	26.5	11.5	12.0	14	22	58
GEV-06LR 1.2	708.1141.125.20	500	1/2	28.0	13.0	14.0	14	27	100
GEV-08LR 1.8	708.1141.160.20	500	1/8	23.5	8.5	8.0	17	14	32
● GEV-08LR 1.4	708.1141.170.20	500	1/4	25.0	10.0	12.0	17	19	43
GEV-08LR 3.8	708.1141.180.20	500	3/8	27.5	12.5	12.0	17	22	59
GEV-08LR 1.2	708.1141.185.20	500	1/2	28.0	13.0	14.0	17	27	99
GEV-10LR 1.8	708.1141.265.20	500	1/8	25.5	10.5	8.0	19	17	43
● GEV-10LR 1.4	708.1141.270.20	500	1/4	26.0	11.0	12.0	19	19	50
GEV-10LR 3.8	708.1141.280.20	500	3/8	27.5	12.5	12.0	19	22	64
GEV-10LR 1.2	708.1141.285.20	500	1/2	29.0	14.0	14.0	19	27	102
GEV-12LR 1.8	708.1141.375.20	400	1/8	26.5	11.5	8.0	22	19	58
GEV-12LR 1.4	708.1141.380.20	400	1/4	27.0	12.0	12.0	22	19	62
● GEV-12LR 3.8	708.1141.390.20	400	3/8	27.5	12.5	12.0	22	22	70
GEV-12LR 1.2	708.1141.400.20	400	1/2	28.0	13.0	14.0	22	27	101
GEV-12LR 3.4	708.1141.405.20	400	3/4	29.0	14.0	16.0	22	32	104
GEV-15LR 1.4	708.1141.528.20	400	1/4	28.0	13.0	12.0	27	24	98
GEV-15LR 3.8	708.1141.532.20	400	3/8	28.5	13.5	12.0	27	24	102
● GEV-15LR 1.2	708.1141.534.20	400	1/2	29.0	14.0	14.0	27	27	114
GEV-15LR 3.4	708.1141.536.20	400	3/4	30.0	15.0	16.0	27	32	172
GEV-18LR 3.8	708.1141.644.20	400	3/8	31.0	14.5	12.0	32	27	136
● GEV-18LR 1.2	708.1141.646.20	400	1/2	31.0	14.5	14.0	32	27	142
GEV-18LR 3.4	708.1141.648.20	400	3/4	31.0	14.5	16.0	32	32	185
GEV-22LR 3.8	708.1141.763.20	250	3/8	32.5	16.0	12.0	36	32	180
GEV-22LR 1.2	708.1141.764.20	250	1/2	33.0	16.5	14.0	36	32	200
● GEV-22LR 3.4	708.1141.768.20	250	3/4	33.0	16.5	16.0	36	32	196
GEV-22LR 1.1	708.1141.770.20	250	1	34.0	17.5	18.0	36	41	289
GEV-22LR 5.4	708.1141.771.20	250	1 1/4	35.0	18.5	20.0	36	50	368

Fortsetzung auf nächster rechter Seite

To be continued on next right page

Continuación próxima página derecha

**Gerade Einschraubstutzen**

Abdichtung durch Dichtkante Form B nach DIN 3852-2

**Straight male adaptor connectors**

sealing edge form B acc. DIN 3852-2

**Cuerpos para roscar rectos**

cierre hermético mediante borde de obturación forma B según DIN 3852-2

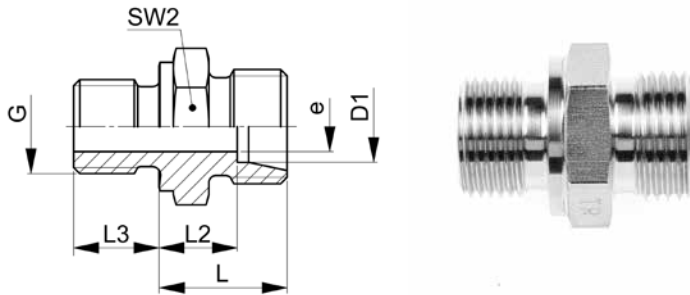

**XGEV-..LR**

Type-D1 G	Mat.-Nr.	PN	G	L	L2	L3	SW2	e	g/Stk
G=Rohrgewinde (zylindrisch)		G=BSP thread (parallel)							
									G=rosca de conexión (cilíndrica)
XGEV-28LR 1.2	706.1141.840.20	250	1/2	25.0	17.5	14.0	41	14.0	158
XGEV-28LR 3.4	706.1141.845.20	250	3/4	25.0	17.5	16.0	41	18.0	165
● XGEV-28LR 1.1	706.1141.850.20	250	1	25.0	17.5	18.0	41	23.0	173
XGEV-28LR 5.4	706.1141.860.20	250	1 1/4	26.0	18.5	20.0	50	23.0	328
XGEV-35LR 1.2	706.1141.920.20	250	1/2	28.0	17.5	14.0	46	14.0	198
XGEV-35LR 3.4	706.1141.915.20	250	3/4	28.0	17.5	16.0	46	18.0	236
XGEV-35LR 1.1	706.1141.925.20	250	1	28.0	17.5	18.0	46	23.0	247
● XGEV-35LR 5.4	706.1141.944.20	250	1 1/4	28.0	17.5	20.0	50	30.0	281
XGEV-35LR 3.2	706.1141.950.20	250	1 1/2	30.0	19.5	22.0	55	30.0	433
XGEV-42LR 1.1	706.1141.980.20	250	1	30.0	19.0	18.0	55	23.0	364
XGEV-42LR 5.4	706.1141.985.20	250	1 1/4	30.0	19.0	20.0	55	30.0	368
● XGEV-42LR 3.2	706.1141.992.20	250	1 1/2	30.0	19.0	22.0	55	36.0	361

ISO 8434-1-SDS-B

**Gerade Einschraubverschraubungen**

Abdichtung durch Dichtkante Form B nach DIN 3852-2

**Straight male adaptor fittings**

sealing edge form B acc. DIN 3852-2

**Racores para roscar rectos**

cierre hermético mediante borde de obturación forma B según DIN 3852-2

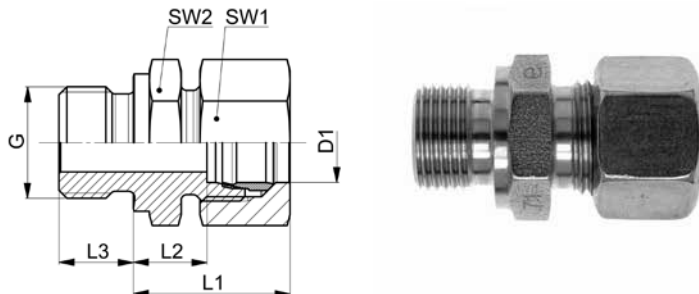

10

**GEV-..LR**

Type-D1 G	Mat.-Nr.	PN	G	L1	L2	L3	SW1	SW2	g/Stk
G=Rohrgewinde (zylindrisch)		G=BSP thread (parallel)				G=rosca de conexión (cilíndrica)			
GEV-28LR 1.2	708.1141.840.20	250	1/2	34.0	17.5	14.0	41	41	210
GEV-28LR 3.4	708.1141.845.20	250	3/4	34.0	17.5	16.0	41	41	230
● GEV-28LR 1.1	708.1141.850.20	250	1	34.0	17.5	18.0	41	41	270
GEV-28LR 5.4	708.1141.860.20	250	1 1/4	35.0	18.5	20.0	41	50	247
GEV-35LR 1.2	708.1141.920.20	250	1/2	39.0	17.5	14.0	50	46	380
GEV-35LR 3.4	708.1141.915.20	250	3/4	39.0	17.5	16.0	50	46	400
GEV-35LR 1.1	708.1141.925.20	250	1	39.0	17.5	18.0	50	46	412
● GEV-35LR 5.4	708.1141.944.20	250	1 1/4	39.0	17.5	20.0	50	55	465
GEV-35LR 3.2	708.1141.950.20	250	1 1/2	41.0	19.5	22.0	50	50	598
GEV-42LR 1.1	708.1141.980.20	250	1	42.0	19.0	18.0	60	55	562
GEV-42LR 5.4	708.1141.985.20	250	1 1/4	42.0	19.0	20.0	60	55	620
● GEV-42LR 3.2	708.1141.992.20	250	1 1/2	42.0	19.0	22.0	60	55	610

Baumaße sind Ungefährmaße bei angezogener Überwurfmutter.

Sizes are approximate dimensions at tightened nut.

Las medidas son aproximadas con la tuerca de unión apretada.

**ISO 8434-1-SDSC-B**

**Gerade Einschraubstutzen**

Abdichtung durch Profildichtring Form E nach ISO 1179-2

**Straight male adaptor connectors**

profile sealing ring form E acc. ISO 1179-2

**Cuerpos para roscar rectos**

cierre hermético mediante junta con perfil forma E según ISO 1179-2

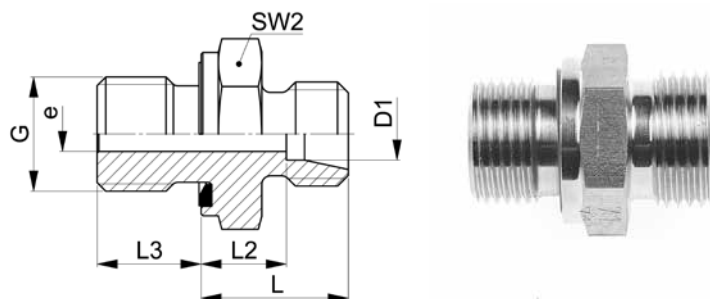

**XGEV-..LR WD**

Type-D1 G	Mat.-Nr.	PN	G	L	L2	L3	SW2	e	g/Stk
G=Rohrgewinde (zylindrisch)		G=BSP thread (parallel)			G=rosca de conexión (cilíndrica)				
● XGEV-04LLR 1.8 WD	707.1171.060.10	100	1/8	13.0	9.5	8.0	14	3.0	12
● XGEV-06LLR 1.8 WD	707.1171.100.10	100	1/8	13.5	8.0	8.0	14	4.5	10
● XGEV-08LLR 1.8 WD	707.1171.160.10	100	1/8	14.5	9.0	8.0	14	4.5	12
● XGEV-06LR 1.8 WD	707.1171.100.20	500	1/8	15.5	8.5	8.0	14	4.0	14
XGEV-06LR 1.4 WD	707.1171.110.20	500	1/4	17.0	10.0	12.0	19	4.0	28
XGEV-06LR 3.8 WD	707.1171.120.20	500	3/8	18.5	11.5	12.0	22	4.0	46
XGEV-06LR 1.2 WD	707.1171.125.20	500	1/2	20.0	13.0	14.0	27	4.0	80
XGEV-08LR 1.8 WD	707.1171.160.20	500	1/8	16.5	8.5	8.0	14	4.0	17
● XGEV-08LR 1.4 WD	707.1171.170.20	500	1/4	17.0	10.0	12.0	19	6.0	27
XGEV-08LR 3.8 WD	707.1171.180.20	500	3/8	18.5	12.5	12.0	22	6.0	46
XGEV-08LR 1.2 WD	707.1171.185.20	500	1/2	20.0	13.0	14.0	27	6.0	78
XGEV-10LR 1.8 WD	707.1171.265.20	500	1/8	17.5	10.5	8.0	17	4.0	22
● XGEV-10LR 1.4 WD	707.1171.270.20	500	1/4	18.0	11.0	12.0	19	7.0	28
XGEV-10LR 3.8 WD	707.1171.280.20	500	3/8	19.5	12.5	12.0	22	8.0	42
XGEV-10LR 1.2 WD	707.1171.285.20	500	3/8	21.0	14.0	14.0	27	8.0	74
XGEV-12LR 1.8 WD	707.1171.375.20	400	1/8	18.5	11.5	8.0	19	4.0	26
XGEV-12LR 1.4 WD	707.1171.380.20	400	1/4	19.0	12.0	12.0	19	7.0	30
● XGEV-12LR 3.8 WD	707.1171.390.20	400	3/8	19.5	12.5	12.0	22	9.0	43
XGEV-12LR 1.2 WD	707.1171.400.20	400	1/2	20.0	13.0	14.0	27	9.0	71
XGEV-12LR 3.4 WD	707.1171.405.20	400	3/4	21.0	14.0	16.0	32	9.0	124
XGEV-15LR 1.4 WD	707.1171.528.20	400	1/4	20.0	13.0	12.0	24	7.0	52
XGEV-15LR 3.8 WD	707.1171.532.20	400	3/8	20.5	13.5	12.0	24	9.0	55
● XGEV-15LR 1.2 WD	707.1171.534.20	400	1/2	21.0	14.0	14.0	27	11.0	73
XGEV-15LR 3.4 WD	707.1171.536.20	400	3/4	22.0	15.0	16.0	32	11.0	124
XGEV-18LR 3.8 WD	707.1171.644.20	400	3/8	22.0	14.5	12.0	27	9.0	76
● XGEV-18LR 1.2 WD	707.1171.646.20	400	1/2	22.0	14.5	14.0	27	14.0	72
XGEV-18LR 3.4 WD	707.1171.648.20	400	3/4	22.0	14.5	16.0	32	14.0	118
XGEV-22LR 1.2 WD	707.1171.764.20	250	1/2	23.5	16.5	14.0	32	14.0	98
● XGEV-22LR 3.4 WD	707.1171.768.20	250	3/4	24.0	16.5	16.0	32	18.0	104
XGEV-22LR 1.1 WD	707.1171.770.20	250	1	25.0	17.5	18.0	41	18.0	198
XGEV-22LR 5.4 WD	707.1171.771.20	250	1 1/4	26.0	18.5	20.0	50	18.0	292

Fortsetzung auf nächster linker Seite

To be continued on next left page

Continuación próxima página izquierda

**Gerade Einschraubverschraubungen**

Abdichtung durch Profildichtring Form E nach ISO 1179-2

**Straight male adaptor fittings**

profile sealing ring form E acc. ISO 1179-2

**Racores para roscar rectos**

cierre hermético mediante junta con perfil forma E según ISO 1179-2

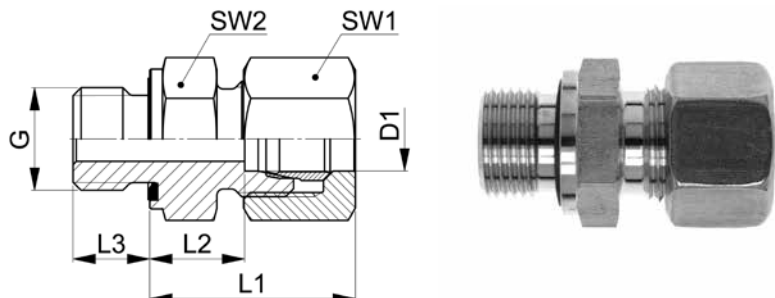

10

**GEV-..LR WD**

Type-D1 G	Mat.-Nr.	PN	G	L1	L2	L3	SW1	SW2	g/Stk
G=Rohrgewinde (zylindrisch)	G=BSP thread (parallel)	G=rosca de conexión (cilíndrica)							
● GEV-04LLR 1.8 WD	708.1171.060.10	100	1/8	20.0	9.5	8.0	10	14	17
● GEV-06LLR 1.8 WD	708.1171.100.10	100	1/8	20.0	8.0	8.0	12	14	19
● GEV-08LLR 1.8 WD	708.1171.160.10	100	1/8	20.5	9.0	8.0	14	14	20
● GEV-06LR 1.8 WD	708.1171.100.20	500	1/8	23.5	8.5	8.0	14	14	25
GEV-06LR 1.4 WD	708.1171.110.20	500	1/4	25.0	10.0	12.0	14	19	40
GEV-06LR 3.8 WD	708.1171.120.20	500	3/8	26.5	11.5	12.0	14	22	58
GEV-06LR 1.2 WD	708.1171.125.20	500	1/2	28.0	13.0	14.0	14	27	100
GEV-08LR 1.8 WD	708.1171.160.20	500	1/8	24.5	8.5	8.0	17	14	37
● GEV-08LR 1.4 WD	708.1171.170.20	500	1/4	25.0	10.0	12.0	17	19	63
GEV-08LR 3.8 WD	708.1171.180.20	500	3/8	26.5	12.5	12.0	17	22	59
GEV-08LR 1.2 WD	708.1171.185.20	500	1/2	28.0	13.0	14.0	17	27	99
● GEV-10LR 1.8 WD	708.1171.265.20	500	1/8	25.5	10.5	8.0	19	17	43
● GEV-10LR 1.4 WD	708.1171.270.20	500	1/4	26.0	11.0	12.0	19	19	50
GEV-10LR 3.8 WD	708.1171.280.20	500	3/8	27.5	12.5	12.0	19	22	64
GEV-10LR 1.2 WD	708.1171.285.20	500	1/2	29.0	14.0	14.0	19	27	102
GEV-12LR 1.8 WD	708.1171.375.20	400	1/8	24.5	11.5	8.0	22	19	54
GEV-12LR 1.4 WD	708.1171.380.20	400	1/4	27.0	12.0	12.0	22	19	62
● GEV-12LR 3.8 WD	708.1171.390.20	400	3/8	27.5	12.5	12.0	22	22	70
GEV-12LR 1.2 WD	708.1171.400.20	400	1/2	28.0	13.0	14.0	22	27	101
GEV-12LR 3.4 WD	708.1171.405.20	400	3/4	29.0	14.0	16.0	22	32	102
GEV-15LR 1.4 WD	708.1171.528.20	400	1/4	28.0	13.0	12.0	27	24	98
GEV-15LR 3.8 WD	708.1171.532.20	400	3/8	28.5	13.5	12.0	27	24	102
● GEV-15LR 1.2 WD	708.1171.534.20	400	1/2	29.0	14.0	14.0	27	27	114
GEV-15LR 3.4 WD	708.1171.536.20	400	3/4	30.0	15.0	16.0	27	32	172
GEV-18LR 3.8 WD	708.1171.644.20	400	3/8	31.0	14.5	12.0	32	27	136
● GEV-18LR 1.2 WD	708.1171.646.20	400	1/2	31.0	14.5	14.0	32	27	142
GEV-18LR 3.4 WD	708.1171.648.20	400	3/4	31.0	14.5	16.0	32	32	185
GEV-22LR 1.2 WD	708.1171.764.20	250	1/2	32.5	16.5	14.0	36	32	200
● GEV-22LR 3.4 WD	708.1171.768.20	250	3/4	33.0	16.5	16.0	36	32	196
GEV-22LR 1.1 WD	708.1171.770.20	250	1	34.0	17.5	18.0	36	41	289
GEV-22LR 5.4 WD	708.1171.771.20	250	1 1/4	35.0	18.5	20.0	36	50	382

Fortsetzung auf nächster rechter Seite

To be continued on next right page

Continuación próxima página derecha

**Gerade Einschraubstutzen**

Abdichtung durch Profildichtring Form E nach ISO 1179-2

**Straight male adaptor connectors**

profile sealing ring form E acc. ISO 1179-2

**Cuerpos para roscar rectos**

cierre hermético mediante junta con perfil forma E según ISO 1179-2

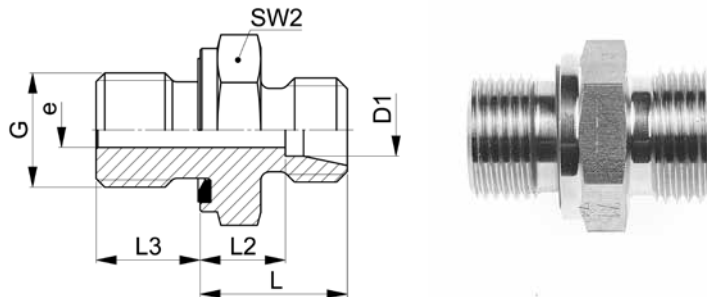

**XGEV-..LR WD**

Type-D1 G	Mat.-Nr.	PN	G	L	L2	L3	SW2	e	g/Stk
G=Rohrgewinde (zylindrisch)		G=BSP thread (parallel)				G=rosca de conexión (cilíndrica)			
XGEV-28LR 1.2 WD	707.1171.840.20	250	1/2	25.0	17.5	14.0	41	14.0	158
XGEV-28LR 3.4 WD	707.1171.845.20	250	3/4	25.0	17.5	16.0	41	18.0	166
● XGEV-28LR 1.1 WD	707.1171.850.20	250	1	25.0	17.5	18.0	41	23.0	169
XGEV-28LR 5.4 WD	707.1171.860.20	250	1 1/4	26.0	18.5	20.0	50	23.0	328
XGEV-35LR 1.2 WD	707.1171.920.20	250	1/2	28.0	17.5	14.0	46	14.0	236
XGEV-35LR 3.4 WD	707.1171.915.20	250	3/4	28.0	17.5	16.0	46	18.0	198
XGEV-35LR 1.1 WD	707.1171.925.20	250	1	28.0	17.5	18.0	46	23.0	248
● XGEV-35LR 5.4 WD	707.1171.944.20	250	1 1/4	28.0	17.5	20.0	50	30.0	284
XGEV-35LR 3.2 WD	707.1171.950.20	250	1 1/2	30.0	19.5	22.0	55	30.0	434
XGEV-42LR 1.1 WD	707.1171.980.20	250	1	30.0	19.0	18.0	55	23.0	306
XGEV-42LR 5.4 WD	707.1171.985.20	250	1 1/4	30.0	19.0	20.0	55	30.0	368
● XGEV-42LR 3.2 WD	707.1171.992.20	250	1 1/2	30.0	19.0	22.0	55	36.0	356

Dichtungsmaterial: FKM

Sealing material: FKM

Material de junta tórica: FKM

**ISO 8434-1-SDS-E**

**Gerade Einschraubverschraubungen**

Abdichtung durch Profildichtring Form E nach ISO 1179-2

**Straight male adaptor fittings**

profile sealing ring form E acc. ISO 1179-2

**Racores para roscar rectos**

cierre hermético mediante junta con perfil forma E según ISO 1179-2

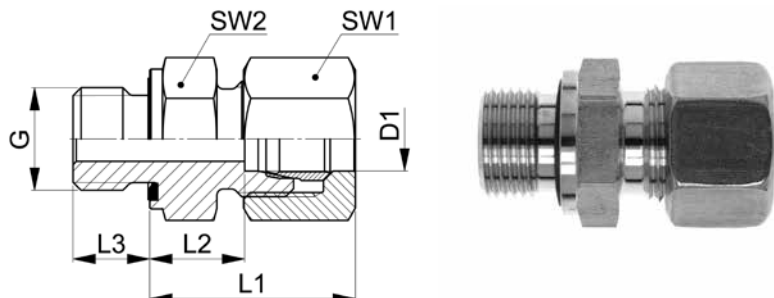

10

**GEV-..LR WD**

Type-D1 G	Mat.-Nr.	PN	G	L1	L2	L3	SW1	SW2	g/Stk
G=Rohrgewinde (zylindrisch)		G=BSP thread (parallel)				G=rosca de conexión (cilíndrica)			
GEV-28LR 1.2 WD	708.1171.840.20	250	1/2	34.0	17.5	14.0	41	41	264
GEV-28LR 3.4 WD	708.1171.845.20	250	3/4	34.0	17.5	16.0	41	41	270
● GEV-28LR 1.1 WD	708.1171.850.20	250	1	34.0	17.5	18.0	41	41	270
GEV-28LR 5.4 WD	708.1171.860.20	250	1 1/4	35.0	18.5	20.0	41	50	427
GEV-35LR 1.2 WD	708.1171.920.20	250	1/2	39.0	17.5	14.0	50	46	416
GEV-35LR 3.4 WD	708.1171.915.20	250	3/4	39.0	17.5	16.0	50	46	400
GEV-35LR 1.1 WD	708.1171.925.20	250	1	39.0	17.5	18.0	50	46	404
● GEV-35LR 5.4 WD	708.1171.944.20	250	1 1/4	39.0	17.5	20.0	50	50	465
GEV-35LR 3.2 WD	708.1171.950.20	250	1 1/2	41.0	19.5	22.0	50	55	594
GEV-42LR 1.1 WD	708.1171.980.20	250	1	42.0	19.0	18.0	60	55	558
GEV-42LR 5.4 WD	708.1171.985.20	250	1 1/4	42.0	19.0	20.0	60	55	626
● GEV-42LR 3.2 WD	708.1171.992.20	250	1 1/2	42.0	19.0	22.0	60	55	642

Baumaße sind Ungefährmaße bei angezogener Überwurfmutter.

Sizes are approximate dimensions at tightened nut.

Las medidas son aproximadas con la tuerca de unión apretada.

Dichtungsmaterial: FKM

Sealing material: FKM

Material de junta tórica: FKM

**ISO 8434-1-SDSC-E**

**Gerade Einschraubstutzen**

Abdichtung durch Dichtkante Form B nach DIN 3852-2

**Straight male adaptor connectors**

sealing edge form B acc. DIN 3852-2

**Cuerpos para roscar rectos**

cierre hermético mediante borde de obturación forma B según DIN 3852-2

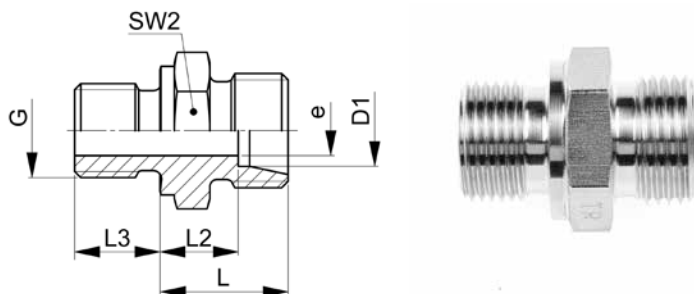

**XGEV-..SR**

Type-D1 G	Mat.-Nr.	PN	G	L	L2	L3	SW2	e	g/Stk
G=Rohrgewinde (zylindrisch)		G=BSP thread (parallel)			G=rosca de conexión (cilíndrica)				
XGEV-06SR 1.8	706.1141.100.30	800	1/8	19.5	12.5	8.0	14	4.0	20
● XGEV-06SR 1.4	706.1141.110.30	800	1/4	20.0	13.0	12.0	19	4.0	36
XGEV-06SR 3.8	706.1141.120.30	800	3/8	22.5	15.5	12.0	22	4.0	58
XGEV-06SR 1.2	706.1141.125.30	800	1/2	25.0	18.0	12.0	27	4.0	100
XGEV-06SR 3.4	706.1141.126.30	800	3/4	27.0	20.0	12.0	32	4.0	123
XGEV-08SR 1.8	706.1141.160.30	800	1/8	21.5	14.5	12.0	17	4.0	21
● XGEV-08SR 1.4	706.1141.170.30	800	1/4	22.0	15.0	12.0	19	5.0	42
XGEV-08SR 3.8	706.1141.180.30	800	3/8	22.5	15.5	12.0	22	5.0	60
XGEV-08SR 1.2	706.1141.185.30	800	1/2	25.0	18.0	14.0	27	5.0	100
XGEV-10SR 1.8	706.1141.265.30	800	1/8	21.5	14.0	8.0	19	4.0	28
XGEV-10SR 1.4	706.1141.270.30	800	1/4	22.0	14.5	12.0	19	5.0	45
● XGEV-10SR 3.8	706.1141.280.30	800	3/8	22.5	15.0	12.0	22	7.0	48
XGEV-10SR 1.2	706.1141.285.30	800	1/2	25.0	17.5	14.0	27	7.0	98
XGEV-10SR 3.4	706.1141.290.30	800	3/4	27.0	19.5	16.0	32	7.0	118
XGEV-12SR 1.4	706.1141.380.30	630	1/4	24.0	16.5	12.0	22	5.0	56
● XGEV-12SR 3.8	706.1141.390.30	630	3/8	24.5	17.0	12.0	22	8.0	64
XGEV-12SR 1.2	706.1141.400.30	630	1/2	25.0	17.5	14.0	27	8.0	99
XGEV-12SR 3.4	706.1141.405.30	630	3/4	25.0	17.5	16.0	32	8.0	154
XGEV-14SR 1.4	706.1141.500.30	630	1/4	24.0	16.0	12.0	24	5.0	62
XGEV-14SR 3.8	706.1141.502.30	630	3/8	26.5	18.5	12.0	24	8.0	76
XGEV-14SR 1.2	706.1141.504.30	630	1/2	27.0	19.0	14.0	27	10.0	99
XGEV-14SR 3.4	706.1141.506.30	630	3/4	29.0	21.0	16.0	32	10.0	164
XGEV-14SR 1.1	706.1141.510.30	630	1	31.0	23.0	18.0	41	10.0	188
XGEV-16SR 3.8	706.1141.564.30	630	3/8	26.5	18.0	12.0	27	8.0	92
● XGEV-16SR 1.2	706.1141.566.30	630	1/2	27.0	18.5	14.0	27	12.0	94
XGEV-16SR 3.4	706.1141.568.30	630	3/4	29.0	20.5	16.0	32	12.0	152
XGEV-16SR 1.1	706.1141.570.30	630	1	31.0	22.5	18.0	41	12.0	290
XGEV-20SR 1.2	706.1141.706.30	420	1/2	31.0	20.5	14.0	32	12.0	144
● XGEV-20SR 3.4	706.1141.708.30	420	3/4	31.0	20.5	16.0	32	16.0	155
XGEV-20SR 1.1	706.1141.712.30	420	1	33.0	22.5	18.0	41	16.0	282
XGEV-20SR 5.4	706.1141.715.30	420	1 1/4	33.0	22.5	20.0	50	16.0	460
XGEV-20SR 3.2	706.1141.717.30	420	1 1/2	36.0	25.5	22.0	55	16.0	664

Fortsetzung auf nächster linker Seite

To be continued on next left page

Continuación próxima página izquierda

## Gerade Einschraubverschraubungen

Abdichtung durch Dichtkante Form B nach DIN 3852-2

## Straight male adaptor fittings

sealing edge form B acc. DIN 3852-2

## Racores para roscar rectos

cierre hermético mediante borde de obturación forma B según DIN 3852-2

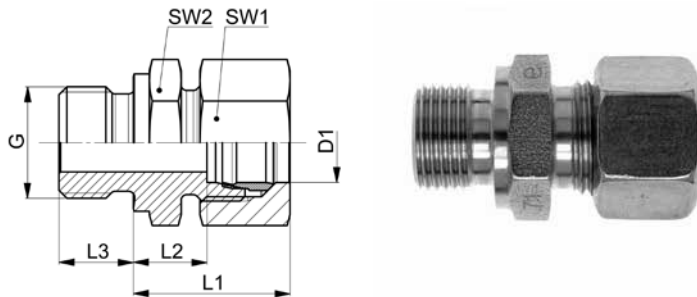

10

### GEV-..SR

Type-D1 G	Mat.-Nr.	PN	G	L1	L2	L3	SW1	SW2	g/Stk
G=Rohrgewinde (zylindrisch)		G=BSP thread (parallel)			G=rosca de conexión (cilíndrica)				
● GEV-06SR 1.8	708.1141.100.30	800	1/8	27.5	12.5	8.0	17	14	40
● GEV-06SR 1.4	708.1141.110.30	800	1/4	28.0	13.0	12.0	17	19	54
● GEV-06SR 3.8	708.1141.120.30	800	3/8	30.5	15.5	12.0	17	22	63
● GEV-06SR 1.2	708.1141.125.30	800	1/2	33.0	18.0	12.0	17	27	107
● GEV-06SR 3.4	708.1141.126.30	800	3/4	35.0	20.0	12.0	17	32	152
● GEV-08SR 1.8	708.1141.160.30	800	1/8	29.5	14.5	12.0	19	17	58
● GEV-08SR 1.4	708.1141.170.30	800	1/4	30.0	15.0	12.0	19	19	63
● GEV-08SR 3.8	708.1141.180.30	800	3/8	30.5	15.5	12.0	19	22	82
● GEV-08SR 1.2	708.1141.185.30	800	1/2	33.0	18.0	14.0	19	27	108
● GEV-10SR 1.8	708.1141.265.30	800	1/8	30.5	14.0	8.0	22	19	77
● GEV-10SR 1.4	708.1141.270.30	800	1/4	31.0	14.5	12.0	22	19	73
● GEV-10SR 3.8	708.1141.280.30	800	3/8	31.5	15.0	12.0	22	22	89
● GEV-10SR 1.2	708.1141.285.30	800	1/2	34.0	17.5	14.0	22	27	125
● GEV-10SR 3.4	708.1141.290.30	800	3/4	36.0	19.5	16.0	22	32	208
● GEV-12SR 1.4	708.1141.380.30	630	1/4	33.0	16.5	12.0	24	22	91
● GEV-12SR 3.8	708.1141.390.30	630	3/8	33.5	17.0	12.0	24	22	100
● GEV-12SR 1.2	708.1141.400.30	630	1/2	34.0	17.5	14.0	24	27	135
● GEV-12SR 3.4	708.1141.405.30	630	3/4	34.0	17.5	16.0	24	32	192
● GEV-14SR 1.4	708.1141.500.30	630	1/4	34.0	16.0	12.0	27	24	118
● GEV-14SR 3.8	708.1141.502.30	630	3/8	36.5	18.5	12.0	27	24	130
● GEV-14SR 1.2	708.1141.504.30	630	1/2	37.0	19.0	14.0	27	27	154
● GEV-14SR 3.4	708.1141.506.30	630	3/4	39.0	21.0	16.0	27	32	195
● GEV-14SR 1.1	708.1141.510.30	630	1	41.0	23.0	18.0	27	41	350
● GEV-16SR 3.8	708.1141.564.30	630	3/8	36.5	18.0	12.0	30	27	156
● GEV-16SR 1.2	708.1141.566.30	630	1/2	37.0	18.5	14.0	30	27	161
● GEV-16SR 3.4	708.1141.568.30	630	3/4	39.0	20.5	16.0	30	32	240
● GEV-16SR 1.1	708.1141.570.30	630	1	41.0	22.5	18.0	30	41	359
● GEV-20SR 1.2	708.1141.706.30	420	1/2	42.0	20.5	14.0	36	32	245
● GEV-20SR 3.4	708.1141.708.30	420	3/4	42.0	20.5	16.0	36	32	277
● GEV-20SR 1.1	708.1141.712.30	420	1	44.0	22.5	18.0	36	41	387
● GEV-20SR 5.4	708.1141.715.30	420	1 1/4	44.0	22.5	20.0	36	50	574
● GEV-20SR 3.2	708.1141.717.30	420	1 1/2	47.0	25.5	22.0	36	55	778

Fortsetzung auf nächster rechter Seite

To be continued on next right page

Continuación próxima página derecha

**Gerade Einschraubstutzen**

Abdichtung durch Dichtkante Form B nach DIN 3852-2

**Straight male adaptor connectors**

sealing edge form B acc. DIN 3852-2

**Cuerpos para roscar rectos**

cierre hermético mediante borde de obturación forma B según DIN 3852-2

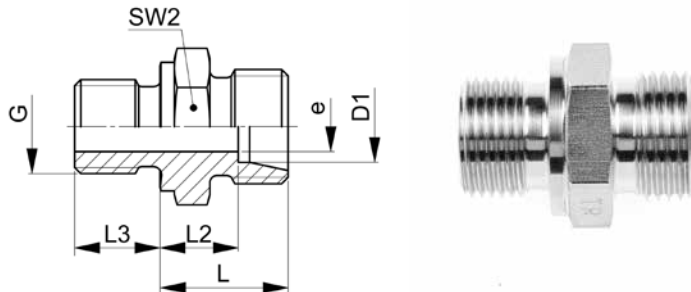

**XGEV-..SR**

Type-D1 G	Mat.-Nr.	PN	G	L	L2	L3	SW2	e	g/Stk
G=Rohrgewinde (zylindrisch)		G=BSP thread (parallel)			G=rosca de conexión (cilíndrica)				
XGEV-25SR 1.2	706.1141.800.30	420	1/2	32.0	20.0	14.0	41	12.0	220
XGEV-25SR 3.4	706.1141.805.30	420	3/4	35.0	23.0	16.0	41	16.0	258
● XGEV-25SR 1.1	706.1141.810.30	420	1	35.0	23.0	18.0	41	20.0	273
XGEV-25SR 5.4	706.1141.815.30	420	1 1/4	35.0	23.0	20.0	50	20.0	452
XGEV-25SR 3.2	706.1141.820.30	420	1 1/2	38.0	26.0	22.0	55	20.0	549
XGEV-30SR 3.4	706.1141.895.30	420	3/4	37.0	23.5	16.0	46	16.0	318
XGEV-30SR 1.1	706.1141.900.30	420	1	37.0	23.5	18.0	46	20.0	356
● XGEV-30SR 5.4	706.1141.902.30	420	1 1/4	37.0	23.5	20.0	50	25.0	430
XGEV-30SR 3.2	706.1141.905.30	420	1 1/2	40.0	26.5	22.0	55	25.0	616
XGEV-38SR 5.4	706.1141.954.30	420	1 1/4	42.0	26.0	20.0	55	25.0	588
● XGEV-38SR 3.2	706.1141.953.30	420	1 1/2	42.0	26.0	22.0	55	32.0	579

**ISO 8434-1-SDS-B**

## Gerade Einschraubverschraubungen

Abdichtung durch Dichtkante Form B nach DIN 3852-2

## Straight male adaptor fittings

sealing edge form B acc. DIN 3852-2

## Racores para roscar rectos

cierre hermético mediante borde de obturación forma B según DIN 3852-2

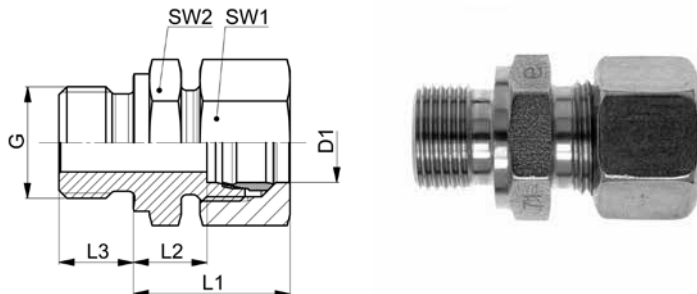

10

### GEV-..SR

Type-D1 G	Mat.-Nr.	PN	G	L1	L2	L3	SW1	SW2	g/Stk
G=Rohrgewinde (zylindrisch)		G=BSP thread (parallel)				G=rosca de conexión (cilíndrica)			
GEV-25SR 1.2	708.1141.800.30	420	1/2	44.0	20.0	14.0	46	41	444
GEV-25SR 3.4	708.1141.805.30	420	3/4	47.0	23.0	16.0	46	41	455
● GEV-25SR 1.1	708.1141.810.30	420	1	47.0	23.0	18.0	46	41	494
GEV-25SR 5.4	708.1141.815.30	420	1 1/4	47.0	23.0	20.0	46	50	674
GEV-25SR 3.2	708.1141.820.30	420	1 1/2	50.0	26.0	22.0	46	55	582
GEV-30SR 3.4	708.1141.895.30	420	3/4	50.0	23.5	16.0	50	46	611
GEV-30SR 1.1	708.1141.900.30	420	1	50.0	23.5	18.0	50	46	630
● GEV-30SR 5.4	708.1141.902.30	420	1 1/4	50.0	23.5	20.0	50	50	670
GEV-30SR 3.2	708.1141.905.30	420	1 1/2	53.0	26.5	22.0	50	55	979
GEV-38SR 5.4	708.1141.954.30	420	1 1/4	55.0	26.0	20.0	60	55	920
● GEV-38SR 3.2	708.1141.953.30	420	1 1/2	55.0	26.0	22.0	60	55	935

Baumaße sind Ungefährmaße bei angezogener Überwurfmutter.

Sizes are approximate dimensions at tightened nuts.

Las medidas son aproximadas con la tuerca de unión apretada.

ISO 8434-1-SDSC-B

**Gerade Einschraubstutzen**

Abdichtung durch Profildichtring Form E nach ISO 1179-2

**Straight male adaptor connectors**

profile sealing ring form E acc. ISO 1179-2

**Cuerpos para roscar rectos**

cierre hermético mediante junta con perfil forma E según ISO 1179-2

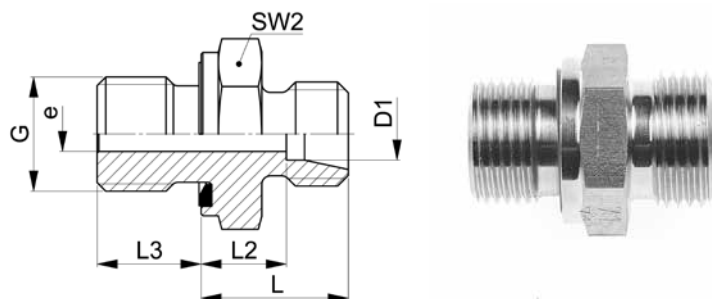

**XGEV-..SR WD**

Type-D1 G	Mat.-Nr.	PN	G	L	L2	L3	SW2	e	g/Stk
G=Rohrgewinde (zylindrisch)		G=BSP thread (parallel)				G=rosca de conexión (cilíndrica)			
XGEV-06SR 1.8 WD	707.1171.100.30	800	1/8	19.5	12.5	8.0	14	4.0	24
● XGEV-06SR 1.4 WD	707.1171.110.30	800	1/4	20.0	13.0	12.0	19	4.0	36
XGEV-06SR 3.8 WD	707.1171.120.30	800	3/8	22.5	15.5	12.0	22	4.0	54
XGEV-06SR 1.2 WD	707.1171.125.30	800	1/2	25.0	18.0	14.0	27	4.0	100
XGEV-06SR 3.4 WD	707.1171.126.30	800	3/4	27.0	20.0	16.0	32	4.0	166
XGEV-08SR 1.8 WD	707.1171.160.30	800	1/8	21.5	14.5	8.0	17	4.0	40
● XGEV-08SR 1.4 WD	707.1171.170.30	800	1/4	22.0	15.0	12.0	19	5.0	41
XGEV-08SR 3.8 WD	707.1171.180.30	800	3/8	22.5	15.5	12.0	22	5.0	58
XGEV-08SR 1.2 WD	707.1171.185.30	800	1/2	25.0	18.0	14.0	27	5.0	100
XGEV-10SR 1.8 WD	707.1171.265.30	800	1/8	21.5	14.0	8.0	19	4.0	32
XGEV-10SR 1.4 WD	707.1171.270.30	800	1/4	22.0	14.5	12.0	19	5.0	44
● XGEV-10SR 3.8 WD	707.1171.280.30	800	3/8	22.5	15.0	12.0	22	7.0	56
XGEV-10SR 1.2 WD	707.1171.285.30	800	1/2	25.0	17.5	14.0	27	7.0	96
XGEV-10SR 3.4 WD	707.1171.290.30	800	3/4	27.0	19.5	16.0	32	7.0	115
XGEV-12SR 1.4 WD	707.1171.380.30	630	1/4	24.0	16.5	12.0	22	5.0	58
● XGEV-12SR 3.8 WD	707.1171.390.30	630	3/8	24.5	17.0	12.0	22	8.0	64
XGEV-12SR 1.2 WD	707.1171.400.30	630	1/2	25.0	17.5	14.0	27	8.0	98
XGEV-12SR 3.4 WD	707.1171.405.30	630	3/4	25.0	17.5	16.0	32	8.0	160
XGEV-14SR 1.4 WD	707.1171.500.30	630	1/4	24.0	16.0	12.0	24	5.0	66
XGEV-14SR 3.8 WD	707.1171.502.30	630	3/8	26.5	18.5	12.0	24	8.0	112
XGEV-14SR 1.2 WD	707.1171.504.30	630	1/2	27.0	19.0	14.0	27	10.0	99
XGEV-14SR 3.4 WD	707.1171.506.30	630	3/4	29.0	21.0	16.0	32	10.0	164
XGEV-16SR 3.8 WD	707.1171.564.30	630	3/8	26.5	18.0	12.0	27	8.0	88
● XGEV-16SR 1.2 WD	707.1171.566.30	630	1/2	27.0	18.5	14.0	27	12.0	94
XGEV-16SR 3.4 WD	707.1171.568.30	630	3/4	29.0	20.5	16.0	32	12.0	155
XGEV-16SR 1.1 WD	707.1171.570.30	630	1	31.0	22.5	18.0	41	12.0	275
XGEV-20SR 1.2 WD	707.1171.706.30	420	1/2	31.0	20.5	14.0	32	12.0	144
● XGEV-20SR 3.4 WD	707.1171.708.30	420	3/4	31.0	20.5	16.0	32	16.0	152
XGEV-20SR 1.1 WD	707.1171.712.30	420	1	33.0	22.5	18.0	41	16.0	296
XGEV-20SR 5.4 WD	707.1171.715.30	420	1 1/4	33.0	22.5	20.0	50	16.0	458
XGEV-20SR 3.2 WD	707.1171.717.30	420	1 1/2	36.0	25.5	22.0	55	16.0	664

Fortsetzung auf nächster linker Seite

To be continued on next left page

Continuación próxima página izquierda

**Gerade Einschraubverschraubungen**

Abdichtung durch Profildichtring Form E nach ISO 1179-2

**Straight male adaptor fittings**

profile sealing ring form E acc. ISO 1179-2

**Racores para roscar rectos**

cierre hermético mediante junta con perfil forma E según ISO 1179-2

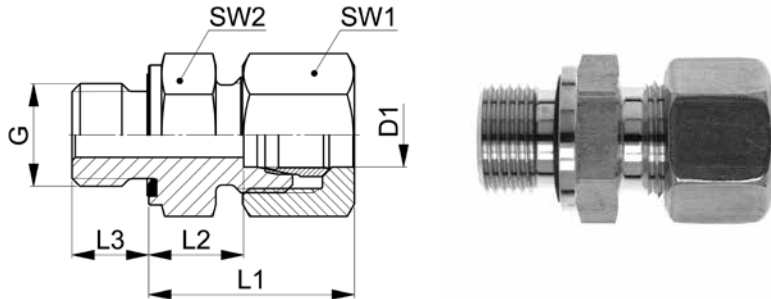

10

**GEV-..SR WD**

Type-D1 G	Mat.-Nr.	PN	G	L1	L2	L3	SW1	SW2	g/Stk
G=Rohrgewinde (zylindrisch)		G=BSP thread (parallel)			G=rosca de conexión (cilíndrica)				
● GEV-06SR 1.8 WD	708.1171.100.30	800	1/8	27.5	12.5	8.0	17	14	40
● GEV-06SR 1.4 WD	708.1171.110.30	800	1/4	28.0	13.0	12.0	17	19	54
● GEV-06SR 3.8 WD	708.1171.120.30	800	3/8	30.5	15.5	12.0	17	22	63
● GEV-06SR 1.2 WD	708.1171.125.30	800	1/2	33.0	18.0	14.0	17	27	107
● GEV-06SR 3.4 WD	708.1171.126.30	800	3/4	35.0	20.0	16.0	17	32	184
● GEV-08SR 1.8 WD	708.1171.160.30	800	1/8	29.5	14.5	8.0	19	17	58
● GEV-08SR 1.4 WD	708.1171.170.30	800	1/4	30.0	15.0	12.0	19	19	63
● GEV-08SR 3.8 WD	708.1171.180.30	800	3/8	30.5	15.5	12.0	19	22	82
● GEV-08SR 1.2 WD	708.1171.185.30	800	1/2	33.0	18.0	14.0	19	27	108
● GEV-10SR 1.8 WD	708.1171.265.30	800	1/8	30.5	14.0	8.0	22	19	48
● GEV-10SR 1.4 WD	708.1171.270.30	800	1/4	31.0	14.5	12.0	22	19	73
● GEV-10SR 3.8 WD	708.1171.280.30	800	3/8	31.5	15.0	12.0	22	22	89
● GEV-10SR 1.2 WD	708.1171.285.30	800	1/2	34.0	17.5	14.0	22	27	125
● GEV-10SR 3.4 WD	708.1171.290.30	800	3/4	36.0	19.5	16.0	22	32	166
● GEV-12SR 1.4 WD	708.1171.380.30	630	1/4	33.0	16.5	12.0	24	22	91
● GEV-12SR 3.8 WD	708.1171.390.30	630	3/8	33.5	17.0	12.0	24	22	100
● GEV-12SR 1.2 WD	708.1171.400.30	630	1/2	34.0	17.5	14.0	24	27	135
● GEV-12SR 3.4 WD	708.1171.405.30	630	3/4	34.0	17.5	16.0	24	32	192
● GEV-14SR 1.4 WD	708.1171.500.30	630	1/4	34.0	16.0	12.0	27	24	120
● GEV-14SR 3.8 WD	708.1171.502.30	630	3/8	36.5	18.5	12.0	27	24	130
● GEV-14SR 1.2 WD	708.1171.504.30	630	1/2	37.0	19.0	14.0	27	27	154
● GEV-14SR 3.4 WD	708.1171.506.30	630	3/4	39.0	21.0	16.0	27	32	195
● GEV-16SR 3.8 WD	708.1171.564.30	630	3/8	36.5	18.0	12.0	30	27	156
● GEV-16SR 1.2 WD	708.1171.566.30	630	1/2	37.0	18.5	14.0	30	27	161
● GEV-16SR 3.4 WD	708.1171.568.30	630	3/4	39.0	20.5	16.0	30	32	226
● GEV-16SR 1.1 WD	708.1171.570.30	630	1	41.0	22.5	18.0	30	41	348
● GEV-20SR 1.2 WD	708.1171.706.30	420	1/2	42.0	20.5	14.0	36	32	245
● GEV-20SR 3.4 WD	708.1171.708.30	420	3/4	42.0	20.5	16.0	36	32	277
● GEV-20SR 1.1 WD	708.1171.712.30	420	1	44.0	22.5	18.0	36	41	387
● GEV-20SR 5.4 WD	708.1171.715.30	420	1 1/4	44.0	22.5	20.0	36	50	574
● GEV-20SR 3.2 WD	708.1171.717.30	420	1 1/2	47.0	25.5	22.0	36	55	782

Fortsetzung auf nächster rechter Seite

To be continued on next right page

Continuación próxima página derecha

**Gerade Einschraubstutzen**

Abdichtung durch Profildichtring Form E nach ISO 1179-2

**Straight male adaptor connectors**

profile sealing ring form E acc. ISO 1179-2

**Cuerpos para roscar rectos**

cierre hermético mediante junta con perfil forma E según ISO 1179-2

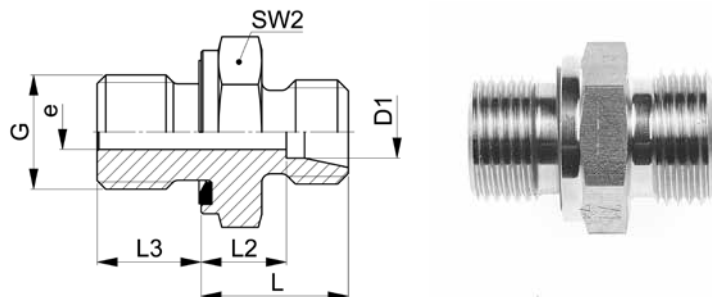

**XGEV-..SR WD**

Type-D1 G	Mat.-Nr.	PN	G	L	L2	L3	SW2	e	g/Stk
G=Rohrgewinde (zylindrisch)		G=BSP thread (parallel)				G=rosca de conexión (cilíndrica)			
XGEV-25SR 1.2 WD	707.1171.800.30	420	1/2	32.0	20.0	14.0	41	12.0	220
XGEV-25SR 3.4 WD	707.1171.805.30	420	3/4	35.0	23.0	16.0	41	16.0	254
● XGEV-25SR 1.1 WD	707.1171.810.30	420	1	35.0	23.0	18.0	41	20.0	270
XGEV-25SR 5.4 WD	707.1171.815.30	420	1 1/4	35.0	23.0	20.0	50	20.0	450
XGEV-25SR 3.2 WD	707.1171.820.30	420	1 1/2	38.0	26.0	22.0	55	20.0	648
XGEV-30SR 3.4 WD	707.1171.895.30	420	3/4	37.0	23.5	16.0	46	16.0	318
XGEV-30SR 1.1 WD	707.1171.900.30	420	1	37.0	23.5	18.0	46	20.0	352
● XGEV-30SR 5.4 WD	707.1171.902.30	420	1 1/4	37.0	23.5	20.0	50	25.0	426
XGEV-30SR 3.2 WD	707.1171.905.30	420	1 1/2	40.0	26.5	22.0	55	25.0	620
XGEV-38SR 1.1 WD	707.1171.960.30	420	1	39.0	26.0	18.0	55	20.0	580
● XGEV-38SR 5.4 WD	707.1171.954.30	420	1 1/4	39.0	23.0	20.0	55	25.0	520
XGEV-38SR 3.2 WD	707.1171.953.30	420	1 1/2	42.0	26.0	22.0	55	32.0	640

Dichtungsmaterial: FKM

Sealing material: FKM

Material de junta tórica: FKM

**ISO 8434-1-SDS-E**

**Gerade Einschraubverschraubungen**

Abdichtung durch Profildichtring Form E nach ISO 1179-2

**Straight male adaptor fittings**

profile sealing ring form E acc. ISO 1179-2

**Racores para roscar rectos**

cierre hermético mediante junta con perfil forma E según ISO 1179-2

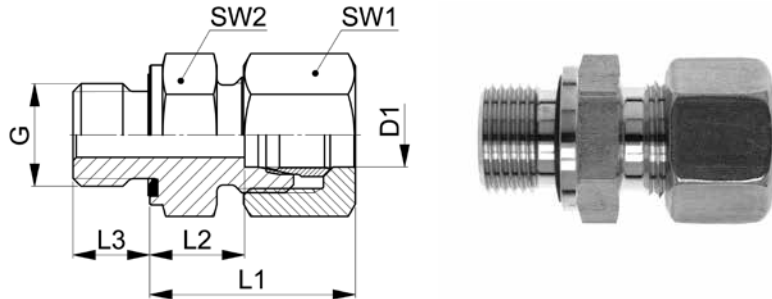

10

**GEV-..SR WD**

Type-D1 G	Mat.-Nr.	PN	G	L1	L2	L3	SW1	SW2	g/Stk
G=Rohrgewinde (zylindrisch)		G=BSP thread (parallel)				G=rosca de conexión (cilíndrica)			
GEV-25SR 1.2 WD	708.1171.800.30	420	1/2	44.0	20.0	14.0	46	41	456
GEV-25SR 3.4 WD	708.1171.805.30	420	3/4	47.0	23.0	16.0	46	41	455
● GEV-25SR 1.1 WD	708.1171.810.30	420	1	47.0	23.0	18.0	46	41	494
GEV-25SR 5.4 WD	708.1171.815.30	420	1 1/4	47.0	23.0	20.0	46	50	674
GEV-25SR 3.2 WD	708.1171.820.30	420	1 1/2	50.0	26.0	22.0	46	55	872
GEV-30SR 3.4 WD	708.1171.895.30	420	3/4	50.0	23.5	16.0	50	46	568
GEV-30SR 1.1 WD	708.1171.900.30	420	1	50.0	23.5	18.0	50	46	580
● GEV-30SR 5.4 WD	708.1171.902.30	420	1 1/4	50.0	23.5	20.0	50	50	670
GEV-30SR 3.2 WD	708.1171.905.30	420	1 1/2	53.0	26.5	22.0	50	55	870
GEV-38SR 1.1 WD	708.1171.960.30	420	1	54.0	26.0	18.0	60	55	935
GEV-38SR 5.4 WD	708.1171.954.30	420	1 1/4	54.0	23.0	20.0	60	55	920
● GEV-38SR 3.2 WD	708.1171.953.30	420	1 1/2	57.0	26.0	22.0	60	55	935

Baumaße sind Ungefährmaße bei angezogener Überwurfmutter.

Sizes are approximate dimensions at tightened nut.

Las medidas son aproximadas con la tuerca de unión apretada.

Dichtungsmaterial: FKM

Sealing material: FKM

Material de junta tórica: FKM

**ISO 8434-1-SDSC-E**

**Gerade Einschraubstutzen**

Abdichtung durch Dichtkante Form B nach DIN 3852-2

**Straight male adaptor connectors**

sealing edge form B acc. DIN 3852-2

**Cuerpos para roscar rectos**

cierre hermético mediante borde de obturación forma B según DIN 3852-2

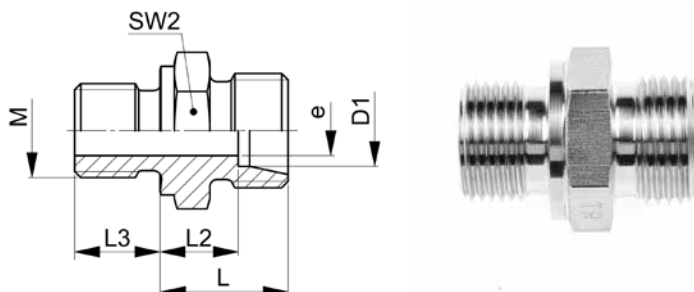

**XGEV-..LM**

Type-D1 M	Mat.-Nr.	PN	M	L	L2	L3	SW2	e	g/Stk
M=metrisches Gewinde (zylindrisch)	M=metric thread (parallel)	M=rosca métrica (cilíndrica)							
● XGEV-06LM 10x1,0	706.1143.180.20	500	10x1.0	15.0	8.5	8.0	14	4.0	15
XGEV-06LM 12x1,5	706.1143.190.20	500	12x1.5	17.0	10.0	12.0	17	4.0	24
● XGEV-08LM 12x1,5	706.1143.240.20	500	12x1.5	17.0	10.0	12.0	17	6.0	22
XGEV-08LM 14x1,5	706.1143.245.20	500	14x1.5	17.0	10.0	12.0	19	6.0	28
XGEV-08LM 18x1,5	706.1143.255.20	500	18x1.5	18.5	11.5	12.0	24	6.0	54
XGEV-10LM 10x1,0	706.1143.270.20	500	10x1.0	17.5	10.5	8.0	17	4.0	20
XGEV-10LM 12x1,5	706.1143.275.20	500	12x1.5	18.0	11.0	12.0	17	6.0	24
● XGEV-10LM 14x1,5	706.1143.280.20	500	14x1.5	18.0	11.0	12.0	19	7.0	30
XGEV-10LM 16x1,5	706.1143.285.20	500	16x1.5	19.5	12.5	12.0	22	8.0	42
XGEV-10LM 18x1,5	706.1143.288.20	500	18x1.5	19.5	12.5	12.0	24	8.0	50
XGEV-10LM 22x1,5	706.1143.290.20	500	22x1.5	21.0	14.0	14.0	27	8.0	85
XGEV-12LM 14x1,5	706.1143.327.20	400	14x1.5	19.0	12.0	12.0	19	7.0	34
● XGEV-12LM 16x1,5	706.1143.330.20	400	16x1.5	19.5	12.5	12.0	22	9.0	40
XGEV-12LM 18x1,5	706.1143.333.20	400	18x1.5	19.5	12.5	12.0	24	9.0	50
XGEV-12LM 22x1,5	706.1143.338.20	400	22x1.5	21.0	14.0	14.0	27	9.0	80
● XGEV-15LM 18x1,5	706.1143.390.20	400	18x1.5	20.5	13.5	12.0	24	11.0	50
XGEV-15LM 22x1,5	706.1143.395.20	400	22x1.5	22.0	15.0	14.0	27	12.0	76
● XGEV-18LM 22x1,5	706.1143.460.20	400	22x1.5	22.0	14.5	14.0	27	14.0	76
XGEV-18LM 26x1,5	706.1143.465.20	400	26x1.5	22.0	14.5	16.0	32	14.0	88
● XGEV-22LM 26x1,5	706.1143.535.20	250	26x1.5	24.0	16.5	16.0	32	18.0	104
● XGEV-28LM 33x2,0	706.1143.570.20	250	33x2.0	25.0	17.5	18.0	41	23.0	168
● XGEV-35LM 42x2,0	706.1143.600.20	250	42x2.0	28.0	17.5	20.0	50	30.0	278
● XGEV-42LM 48x2,0	706.1143.992.20	250	48x2.0	30.0	19.0	22.0	55	36.0	340

**ISO 8434-1-SDS-B**

## Gerade Einschraubverschraubungen

Abdichtung durch Dichtkante Form B nach DIN 3852-2

## Straight male adaptor fittings

sealing edge form B acc. DIN 3852-2

## Racores para roscar rectos

cierre hermético mediante borde de obturación forma B según DIN 3852-2

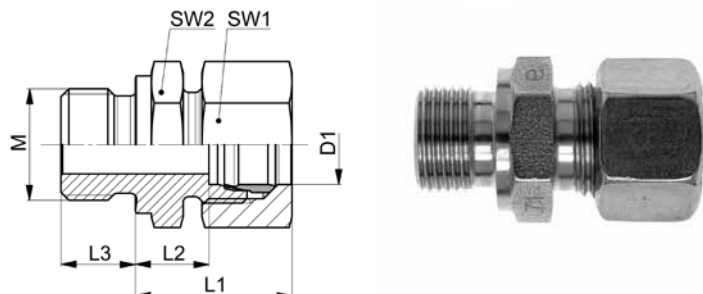

10

### GEV-..LM

Type-D1 M	Mat.-Nr.	PN	M	L1	L2	L3	SW1	SW2	g/Stk
M=metrisches Gewinde (zylindrisch)	M=metric thread (parallel)	M=rosca métrica (cilíndrica)							
● GEV-06LM 10x1,0	708.1143.180.20	500	10x1.0	23.5	8.5	8.0	14	14	27
GEV-06LM 12x1,5	708.1143.190.20	500	12x1.5	25.0	10.0	12.0	14	17	36
● GEV-08LM 12x1,5	708.1143.240.20	500	12x1.5	25.0	10.0	12.0	17	17	39
GEV-08LM 14x1,5	708.1143.245.20	500	14x1.5	25.0	10.0	12.0	17	19	45
GEV-08LM 18x1,5	708.1143.255.20	500	18x1.5	26.5	11.5	12.0	17	24	71
GEV-10LM 10x1,0	708.1143.270.20	500	10x1.0	25.5	10.5	8.0	19	17	44
GEV-10LM 12x1,5	708.1143.275.20	500	12x1.5	26.0	11.0	12.0	19	17	46
● GEV-10LM 14x1,5	708.1143.280.20	500	14x1.5	26.0	11.0	12.0	19	19	52
GEV-10LM 16x1,5	708.1143.285.20	500	16x1.5	27.5	12.5	12.0	19	22	66
GEV-10LM 18x1,5	708.1143.288.20	500	18x1.5	27.5	12.5	12.0	19	24	72
GEV-10LM 22x1,5	708.1143.290.20	500	22x1.5	30.0	14.0	14.0	19	27	86
GEV-12LM 14x1,5	708.1143.327.20	400	14x1.5	27.0	12.0	12.0	22	19	61
● GEV-12LM 16x1,5	708.1143.330.20	400	16x1.5	27.5	12.5	12.0	22	22	67
GEV-12LM 18x1,5	708.1143.333.20	400	18x1.5	27.5	12.5	12.0	22	24	77
GEV-12LM 22x1,5	708.1143.338.20	400	22x1.5	29.0	14.0	14.0	22	27	107
● GEV-15LM 18x1,5	708.1143.390.20	400	18x1.5	28.5	13.5	12.0	27	24	95
GEV-15LM 22x1,5	708.1143.395.20	400	22x1.5	30.0	15.0	14.0	27	27	121
● GEV-18LM 22x1,5	708.1143.460.20	400	22x1.5	31.0	14.5	14.0	32	27	143
GEV-18LM 26x1,5	708.1143.465.20	400	26x1.5	31.0	14.5	16.0	32	32	155
● GEV-22LM 26x1,5	708.1143.535.20	250	26x1.5	33.0	16.5	16.0	36	32	191
● GEV-28LM 33x2,0	708.1143.570.20	250	33x2.0	34.0	17.5	18.0	41	41	267
● GEV-35LM 42x2,0	708.1143.600.20	250	42x2.0	39.0	17.5	20.0	50	50	437
● GEV-42LM 48x2,0	708.1143.992.20	250	48x2.0	42.0	19.0	22.0	60	55	581

Baumaße sind Ungefährmaße bei angezogener Überwurfmutter.

Sizes are approximate dimensions at tightened nut.

Las medidas son aproximadas con la tuerca de unión apretada.

ISO 8434-1-SDSC-B

**Gerade Einschraubstutzen**

Abdichtung durch Profildichtring Form E nach ISO 1179-2

**Straight male adaptor connectors**

profile sealing ring form E acc. ISO 1179-2

**Cuerpos para roscar rectos**

cierre hermético mediante junta con perfil forma E según ISO 1179-2

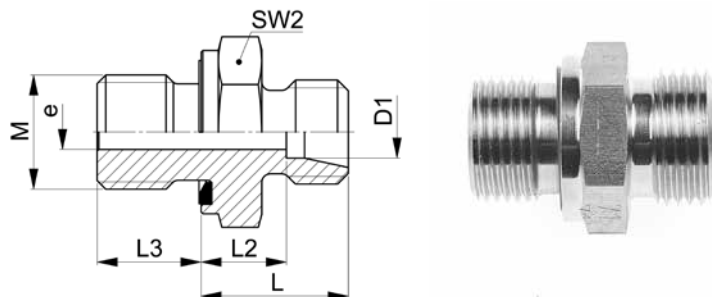

**XGEV-..LM WD**

Type-D1 M	Mat.-Nr.	PN	M	L	L2	L3	SW2	e	g/Stk
M=metrisches Gewinde (zylindrisch)	M=metric thread (parallel)	M=rosca métrica (cilíndrica)							
● XGEV-06LM 10x1,0 WD	707.1173.180.20	500	10x1.0	15.5	8.5	8.0	14	4.0	15
XGEV-06LM 12x1,5 WD	707.1173.190.20	500	12x1.5	17.0	10.0	12.0	17	4.0	25
● XGEV-08LM 12x1,5 WD	707.1173.240.20	500	12x1.5	17.0	10.0	12.0	17	6.0	24
XGEV-08LM 14x1,5 WD	707.1173.245.20	500	14x1.5	17.0	10.0	12.0	19	6.0	31
XGEV-08LM 18x1,5 WD	707.1173.255.20	500	18x1.5	18.5	11.5	12.0	24	6.0	55
XGEV-10LM 10x1,0 WD	707.1173.270.20	500	10x1.0	17.5	10.5	8.0	17	4.0	24
XGEV-10LM 12x1,5 WD	707.1173.275.20	500	12x1.5	18.0	10.0	12.0	17	6.0	27
● XGEV-10LM 14x1,5 WD	707.1173.280.20	500	14x1.5	18.0	11.0	12.0	19	7.0	31
XGEV-10LM 16x1,5 WD	707.1173.285.20	500	16x1.5	19.5	12.5	12.0	22	7.0	46
XGEV-10LM 18x1,5 WD	707.1173.288.20	500	18x1.5	19.5	12.5	12.0	24	8.0	53
XGEV-10LM 22x1,5 WD	707.1173.290.20	500	22x1.5	21.0	14.0	14.0	27	8.0	85
XGEV-12LM 14x1,5 WD	707.1173.327.20	400	14x1.5	19.0	12.0	12.0	19	9.0	32
● XGEV-12LM 16x1,5 WD	707.1173.330.20	400	16x1.5	19.5	12.5	12.0	22	9.0	43
XGEV-12LM 18x1,5 WD	707.1173.333.20	400	18x1.5	20.0	13.0	12.0	24	9.0	55
XGEV-12LM 22x1,5 WD	707.1173.338.20	400	22x1.5	21.0	14.0	14.0	27	9.0	85
● XGEV-15LM 18x1,5 WD	707.1173.390.20	400	18x1.5	20.5	13.5	12.0	24	12.0	52
XGEV-15LM 22x1,5 WD	707.1173.395.20	400	22x1.5	22.0	15.0	14.0	27	12.0	83
● XGEV-18LM 22x1,5 WD	707.1173.460.20	400	22x1.5	22.0	14.5	14.0	27	15.0	77
XGEV-18LM 26x1,5 WD	707.1173.465.20	400	26x1.5	22.0	14.5	16.0	32	15.0	118
● XGEV-22LM 26x1,5 WD	707.1173.535.20	250	26x1.5	24.0	16.5	16.0	32	18.0	112
● XGEV-28LM 33x2,0 WD	707.1173.570.20	250	33x2.0	25.0	17.5	18.0	41	23.0	182
● XGEV-35LM 42x2,0 WD	707.1173.600.20	250	42x2.0	28.0	17.5	20.0	50	30.0	301
● XGEV-42LM 48x2,0 WD	707.1173.992.20	250	48x2.0	30.0	19.0	22.0	55	36.0	382

Dichtungsmaterial: FKM

Sealing material: FKM

Material de junta tórica: FKM

**ISO 8434-1-SDS-E**

**Gerade Einschraubverschraubungen**

Abdichtung durch Profildichtring Form E nach ISO 1179-2

**Straight male adaptor fittings**

profile sealing ring form E acc. ISO 1179-2

**Racores para roscar rectos**

cierre hermético mediante junta con perfil forma E según ISO 1179-2

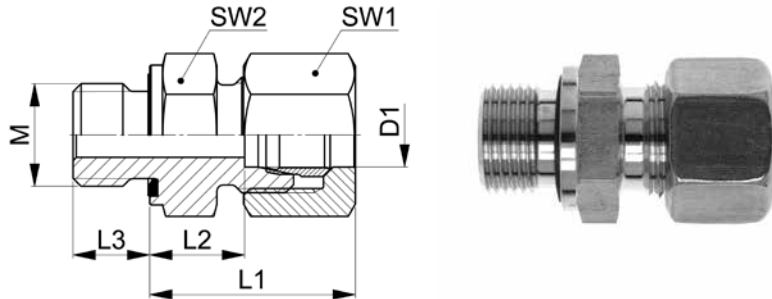

10

**GEV-..LM WD**

Type-D1 M	Mat.-Nr.	PN	M	L1	L2	L3	SW1	SW2	g/Stk
M=metrisches Gewinde (zylindrisch)	M=metric thread (parallel)	M=rosca métrica (cilíndrica)							
● GEV-06LM 10x1,0 WD	708.1173.180.20	500	10x1.0	23.5	8.5	8.0	14	14	24
GEV-06LM 12x1,5 WD	708.1173.190.20	500	12x1.5	25.0	10.0	12.0	14	17	34
● GEV-08LM 12x1,5 WD	708.1173.240.20	500	12x1.5	25.0	10.0	12.0	17	17	37
GEV-08LM 14x1,5 WD	708.1173.245.20	500	14x1.5	25.0	10.0	12.0	17	19	45
GEV-08LM 18x1,5 WD	708.1173.255.20	500	18x1.5	26.5	11.5	12.0	17	24	79
GEV-10LM 10x1,0 WD	708.1173.270.20	500	10x1.0	25.5	10.5	8.0	19	17	66
GEV-10LM 12x1,5 WD	708.1173.275.20	500	12x1.5	26.0	11.0	12.0	19	17	46
● GEV-10LM 14x1,5 WD	708.1173.280.20	500	14x1.5	26.0	11.0	12.0	19	19	50
GEV-10LM 16x1,5 WD	708.1173.285.20	500	16x1.5	27.5	12.5	12.0	19	22	64
GEV-10LM 18x1,5 WD	708.1173.288.20	500	18x1.5	27.5	12.5	12.0	19	24	94
GEV-10LM 22x1,5 WD	708.1173.290.20	500	22x1.5	30.0	14.0	14.0	19	27	86
GEV-12LM 14x1,5 WD	708.1173.327.20	400	14x1.5	27.0	12.0	12.0	22	19	89
● GEV-12LM 16x1,5 WD	708.1173.330.20	400	16x1.5	27.5	12.5	12.0	22	22	67
GEV-12LM 18x1,5 WD	708.1173.333.20	400	18x1.5	28.0	13.0	12.0	22	24	79
GEV-12LM 22x1,5 WD	708.1173.338.20	400	22x1.5	29.0	14.0	14.0	22	27	117
● GEV-15LM 18x1,5 WD	708.1173.390.20	400	18x1.5	28.5	13.5	12.0	27	24	95
GEV-15LM 22x1,5 WD	708.1173.395.20	400	22x1.5	30.0	15.0	14.0	27	27	121
● GEV-18LM 22x1,5 WD	708.1173.460.20	400	22x1.5	31.0	14.5	14.0	32	27	141
GEV-18LM 26x1,5 WD	708.1173.465.20	400	26x1.5	31.0	14.5	16.0	32	32	169
● GEV-22LM 26x1,5 WD	708.1173.535.20	250	26x1.5	33.0	16.5	16.0	36	32	189
● GEV-28LM 33x2,0 WD	708.1173.570.20	250	33x2.0	34.0	17.5	18.0	41	41	267
● GEV-35LM 42x2,0 WD	708.1173.600.20	250	42x2.0	39.0	17.5	20.0	50	50	461
● GEV-42LM 48x2,0 WD	708.1173.992.20	250	48x2.0	42.5	19.0	22.0	60	55	599

Baumaße sind Ungefährmaße bei angezogener Überwurfmutter.

Sizes are approximate dimensions at tightened nut.

Las medidas son aproximadas con la tuerca de unión apretada.

Dichtungsmaterial: FKM

Sealing material: FKM

Material de junta tórica: FKM

**ISO 8434-1-SDSC-E**

**Gerade Einschraubstutzen**

Abdichtung durch Dichtkante Form B nach DIN 3852-2

**Straight male adaptor connectors**

sealing edge form B acc. DIN 3852-2

**Cuerpos para roscar rectos**

cierre hermético mediante borde de obturación forma B según DIN 3852-2

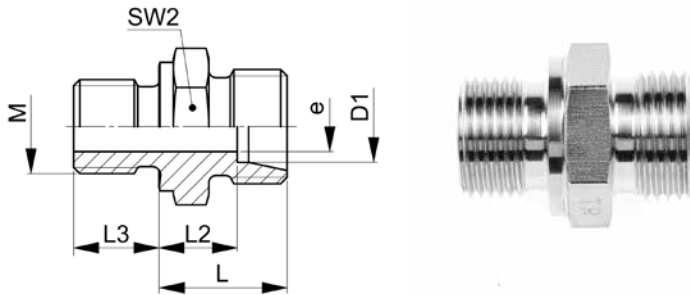

**XGEV-..SM**

Type-D1 M	Mat.-Nr.	PN	M	L	L2	L3	SW2	e	g/Stk
M=metrisches Gewinde (zylindrisch)		M=metric thread (parallel)			M=rosca métrica (cilíndrica)				
● XGEV-06SM 12x1,5	706.1143.195.30	800	12x1.5	20.0	13.0	12.0	17	4.0	30
XGEV-06SM 14x1,5	706.1143.198.30	800	14x1.5	20.0	13.0	12.0	19	4.0	38
● XGEV-08SM 14x1,5	706.1143.245.30	800	14x1.5	22.0	15.0	12.0	19	5.0	42
● XGEV-10SM 16x1,5	706.1143.285.30	800	16x1.5	22.5	15.0	12.0	22	7.0	54
XGEV-12SM 14x1,5	706.1143.327.30	630	14x1.5	24.0	15.0	12.0	22	8.0	59
● XGEV-12SM 18x1,5	706.1143.333.30	630	18x1.5	24.5	17.0	12.0	24	8.0	72
XGEV-14SM 20x1,5	706.1143.382.30	630	20x1.5	27.0	19.0	14.0	27	10.0	90
● XGEV-16SM 22x1,5	706.1143.410.30	630	22x1.5	27.0	18.5	14.0	27	12.0	98
● XGEV-20SM 27x2,0	706.1143.506.30	420	27x2.0	31.0	20.5	16.0	32	16.0	165
● XGEV-25SM 33x2,0	706.1143.550.30	420	33x2.0	35.0	23.0	18.0	41	20.0	274
● XGEV-30SM 42x2,0	706.1143.590.30	420	42x2.0	37.0	23.5	20.0	50	25.0	434
● XGEV-38SM 48x2,0	706.1143.954.30	420	48x2.0	42.0	26.0	22.0	55	32.0	580

**ISO 8434-1-SDS-B**

**Gerade Einschraubverschraubungen**

Abdichtung durch Dichtkante Form B nach DIN 3852-2

**Straight male adaptor fittings**

sealing edge form B acc. DIN 3852-2

**Racores para roscar rectos**

cierre hermético mediante borde de obturación forma B según DIN 3852-2

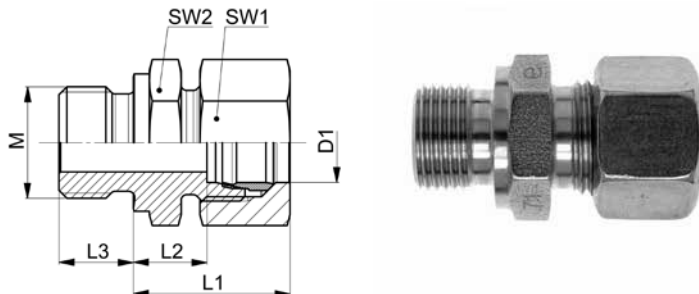

10

**GEV-..SM**

Type-D1 M	Mat.-Nr.	PN	M	L1	L2	L3	SW1	SW2	g/Stk
M=metrisches Gewinde (zylindrisch)	M=metric thread (parallel)	M=rosca métrica (cilíndrica)							
● GEV-06SM 12x1,5	708.1143.195.30	800	12x1.5	28.0	13.0	12.0	17	17	48
● GEV-06SM 14x1,5	708.1143.198.30	800	14x1.5	30.0	13.0	12.0	17	19	56
● GEV-08SM 14x1,5	708.1143.245.30	800	14x1.5	30.0	15.0	12.0	19	19	64
● GEV-10SM 16x1,5	708.1143.285.30	800	16x1.5	31.5	15.0	12.0	22	22	88
● GEV-12SM 14x1,5	708.1143.327.30	630	14x1.5	33.0	15.0	12.0	24	22	96
● GEV-12SM 18x1,5	708.1143.333.30	630	18x1.5	33.5	17.0	12.0	24	24	110
● GEV-14SM 20x1,5	708.1143.382.30	630	20x1.5	37.0	19.0	14.0	27	27	150
● GEV-16SM 22x1,5	708.1143.410.30	630	22x1.5	37.0	18.5	14.0	30	27	165
● GEV-20SM 27x2,0	708.1143.506.30	420	27x2.0	42.0	20.5	16.0	36	32	265
● GEV-25SM 33x2,0	708.1143.550.30	420	33x2.0	47.0	23.0	18.0	46	41	490
● GEV-30SM 42x2,0	708.1143.590.30	420	42x2.0	50.0	23.5	20.0	50	50	690
● GEV-38SM 48x2,0	708.1143.954.30	420	48x2.0	57.0	26.0	22.0	60	55	940

Baumaße sind Ungefährmaße bei angezogener Überwurfmutter.

Sizes are approximate dimensions at tightened nut.

Las medidas son aproximadas con la tuerca de unión apretada.

**ISO 8434-1-SDSC-B**

**Gerade Einschraubstutzen**

Abdichtung durch Profildichtring Form E nach ISO 1179-2

**Straight male adaptor connectors**

profile sealing ring form E acc. ISO 1179-2

**Cuerpos para roscar rectos**

cierre hermético mediante junta con perfil forma E según ISO 1179-2

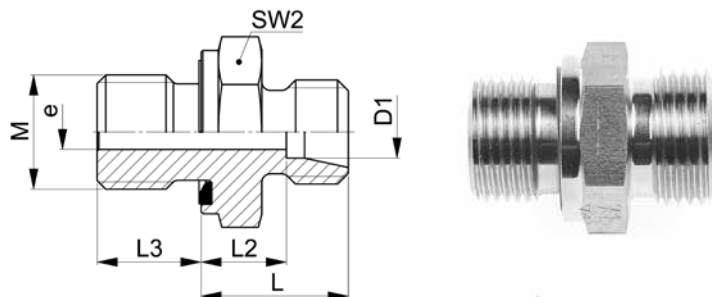

**XGEV-..SM WD**

Type-D1 M	Mat.-Nr.	PN	M	L	L2	L3	SW2	e	g/Stk
M=metrisches Gewinde (zylindrisch)		M=metric thread (parallel)			M=rosca métrica (cilíndrica)				
● XGEV-06SM 12x1,5 WD	707.1173.195.30	800	12x1.5	20.0	13.0	12.0	17	4.0	30
XGEV-06SM 14x1,5 WD	707.1173.198.30	800	14x1.5	22.0	15.0	12.0	19	4.0	42
● XGEV-08SM 14x1,5 WD	707.1173.245.30	800	14x1.5	22.0	15.0	12.0	19	5.0	42
● XGEV-10SM 16x1,5 WD	707.1173.285.30	800	16x1.5	22.5	15.0	12.0	22	7.0	54
XGEV-12SM 14x1,5 WD	707.1173.327.30	630	14x1.5	24.0	16.5	12.0	22	8.0	52
● XGEV-12SM 18x1,5 WD	707.1173.333.30	630	18x1.5	24.5	17.0	12.0	24	8.0	72
XGEV-14SM 20x1,5 WD	707.1173.382.30	630	20x1.5	27.0	19.0	14.0	27	10.0	94
● XGEV-16SM 22x1,5 WD	707.1173.410.30	630	22x1.5	27.0	18.5	14.0	27	12.0	98
● XGEV-20SM 27x2,0 WD	707.1173.506.30	420	27x2.0	31.0	20.5	16.0	32	16.0	152
● XGEV-25SM 33x2,0 WD	707.1173.550.30	420	33x2.0	35.0	23.0	18.0	41	20.0	270
● XGEV-30SM 42x2,0 WD	707.1173.590.30	420	42x2.0	37.0	23.5	20.0	50	25.0	436
● XGEV-38SM 48x2,0 WD	707.1173.954.30	420	48x2.0	42.0	26.0	22.0	55	32.0	580

Dichtungsmaterial: FKM

Sealing material: FKM

Material de junta tórica: FKM

**ISO 8434-1-SDS-E**

**Gerade Einschraubverschraubungen**

Abdichtung durch Profildichtring Form E nach ISO 1179-2

**Straight male adaptor fittings**

profile sealing ring form E acc. ISO 1179-2

**Racores para roscar rectos**

cierre hermético mediante junta con perfil forma E según ISO 1179-2

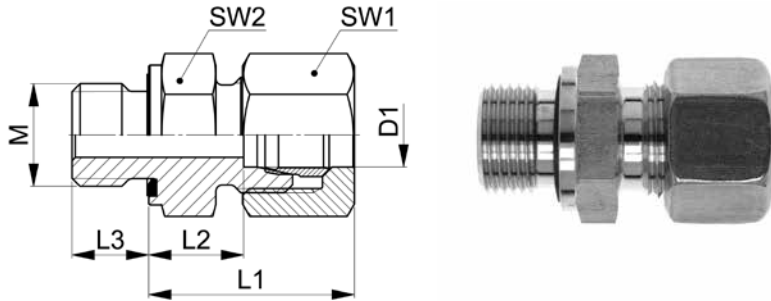

10

**GEV-..SM WD**

Type-D1 M	Mat.-Nr.	PN	M	L1	L2	L3	SW1	SW2	g/Stk
M=metrisches Gewinde (zylindrisch)		M=metric thread (parallel)				M=rosca métrica (cilíndrica)			
● GEV-06SM 12x1,5 WD	708.1173.195.30	800	12x1.5	28.0	13.0	12.0	17	17	48
● GEV-06SM 14x1,5 WD	708.1173.198.30	800	14x1.5	30.0	15.0	12.0	17	19	58
● GEV-08SM 14x1,5 WD	708.1173.245.30	800	14x1.5	30.0	15.0	12.0	19	19	62
● GEV-10SM 16x1,5 WD	708.1173.285.30	800	16x1.5	31.5	15.0	12.0	22	22	88
● GEV-12SM 14x1,5 WD	708.1173.327.30	630	14x1.5	33.0	16.5	12.0	24	22	90
● GEV-12SM 18x1,5 WD	708.1173.333.30	630	18x1.5	33.5	17.0	12.0	24	24	110
● GEV-14SM 20x1,5 WD	708.1173.382.30	630	20x1.5	37.0	19.0	14.0	27	27	150
● GEV-16SM 22x1,5 WD	708.1173.410.30	630	22x1.5	37.0	18.5	14.0	30	27	165
● GEV-20SM 27x2,0 WD	708.1173.506.30	420	27x2.0	42.0	20.5	16.0	36	32	265
● GEV-25SM 33x2,0 WD	708.1173.550.30	420	33x2.0	47.0	23.0	18.0	46	41	490
● GEV-30SM 42x2,0 WD	708.1173.590.30	420	42x2.0	50.0	23.5	20.0	50	50	690
● GEV-38SM 48x2,0 WD	708.1173.954.30	420	48x2.0	57.0	26.0	22.0	60	55	940

Baumaße sind Ungefährmaße bei angezogener Überwurfmutter.

Sizes are approximate dimensions at tightened nut.

Las medidas son aproximadas con la tuerca de unión apretada.

Dichtungsmaterial: FKM

Sealing material: FKM

Material de junta tórica: FKM

**ISO 8434-1-SDSC-E**

**Gerade Einschraubstutzen**

Abdichtung im Kegengewinde Form C nach DIN 3852-2

**Straight male adaptor connectors**

taper thread sealing form C acc. DIN 3852-2

**Cuerpos para roscar rectos**

cierre hermético con rosca cónica forma C según DIN 3852-2

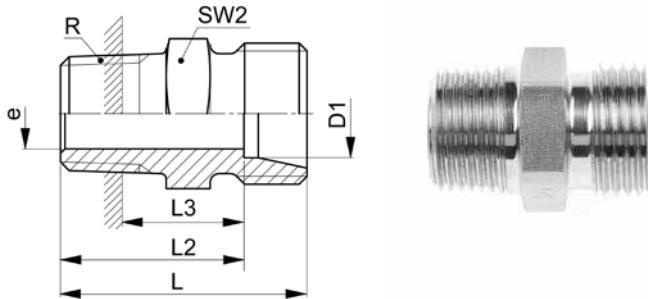

**XGEV-..LRK**

Type-D1 R	Mat.-Nr.	PN	R	L	L2	L3	SW2	e	g/Stk
R=Rohrgewinde (kegelig)		R=BSP thread (tapered)				R=rosca para tubos (cónica)			
● XGEV-04LLRK 1.8	706.1101.060.10	100	1/8	20.0	16.0	11.0	11	3.0	9
● XGEV-06LLRK 1.8	706.1101.100.10	100	1/8	20.0	14.5	9.5	11	4.0	9
● XGEV-08LLRK 1.8	706.1101.160.10	100	1/8	22.0	16.5	11.5	12	6.0	11
XGEV-08LLRK 1.4	706.1101.170.10	100	1/4	26.0	20.5	12.5	14	6.0	20
● XGEV-06LRK 1.8	706.1101.100.20	250	1/8	23.0	16.0	11.0	12	4.0	14
XGEV-06LRK 1.4	706.1101.110.20	250	1/4	27.0	19.0	11.0	14	4.0	23
XGEV-06LRK 3.8	706.1101.120.20	250	3/8	26.0	19.0	11.0	17	4.0	32
XGEV-06LRK 1.2	706.1101.125.20	250	1/2	29.0	22.0	12.0	22	4.0	54
XGEV-08LRK 1.8	706.1101.160.20	250	1/8	23.0	16.0	11.0	14	6.0	17
● XGEV-08LRK 1.4	706.1101.170.20	250	1/4	27.0	20.0	12.0	17	6.0	25
XGEV-08LRK 3.8	706.1101.180.20	250	3/8	27.0	20.0	12.0	17	6.0	33
XGEV-08LRK 1.2	706.1101.185.20	250	1/2	29.0	22.0	12.0	22	6.0	50
XGEV-10LRK 1.8	706.1101.265.20	250	1/8	24.0	17.0	12.0	17	6.0	23
● XGEV-10LRK 1.4	706.1101.270.20	250	1/4	28.0	21.0	13.0	17	8.0	27
XGEV-10LRK 3.8	706.1101.280.20	250	3/8	28.0	21.0	13.0	17	8.0	32
XGEV-10LRK 1.2	706.1101.285.20	250	1/2	30.0	23.0	13.0	22	8.0	50
XGEV-12LRK 1.4	706.1101.380.20	250	1/4	29.0	22.0	14.0	19	8.0	34
● XGEV-12LRK 3.8	706.1101.390.20	250	3/8	29.0	22.0	14.0	19	9.0	37
XGEV-12LRK 1.2	706.1101.400.20	250	1/2	31.0	24.0	14.0	22	9.0	54
XGEV-15LRK 3.8	706.1101.532.20	250	3/8	30.0	23.0	15.0	24	9.0	55
● XGEV-15LRK 1.2	706.1101.534.20	250	1/2	32.0	25.0	15.0	24	12.0	56
● XGEV-18LRK 1.2	706.1101.646.20	160	1/2	33.0	25.5	15.5	27	12.0	75
XGEV-18LRK 3.4	706.1101.648.20	160	3/4	35.0	27.5	15.5	27	15.0	90
XGEV-22LRK 1.2	706.1101.764.20	100	1/2	35.0	27.5	17.5	32	12.0	106
XGEV-22LRK 3.4	706.1101.768.20	100	3/4	37.0	29.5	17.5	32	19.0	95
XGEV-28LRK 1.1	706.1101.850.20	100	1	40.0	32.5	18.5	41	24.0	160
XGEV-35LRK 1.1	706.1101.925.20	100	1	43.0	32.5	18.5	46	24.0	235
XGEV-42LRK 3.2	706.1101.992.20	100	1 1/2	49.0	38.0	24.0	55	36.0	361

Druckangaben gelten in Verbindung mit zylindrischem Innengewinde.

Pressure information applies in connection with parallel female thread.

Datos de presión válidos en combinación con roscas interiores cilíndricas.

Einbaumaß L3 ist abhängig von den Masstoleranzen des Gegenstückes.

Installation size L3 is dependent on the size tolerances of the counterpart.

Distancia de referencia L3 según las tolerancias dimensionales de la contrapieza.

## Gerade Einschraubverschraubungen

Abdichtung durch Kegeligwinde Form C nach DIN 3852-2

## Straight male adaptor fittings

taper thread sealing form C acc. DIN 3852-2

## Racores para roscar rectos

cierre hermético con rosca cónica forma C según DIN 3852-2

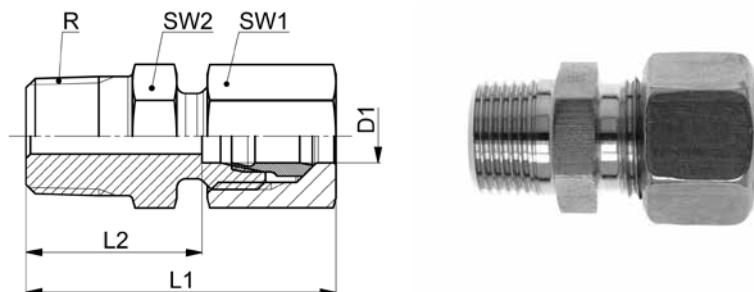

10

### GEV-..LRK

Type-D1 R	Mat.-Nr.	PN	R	L1	L2	SW1	SW2	g/Stk
R=Rohrgewinde (kegelig)		R=BSP thread (tapered)					R=rosca para tubos (cónica)	
● GEV-04LLRK 1.8	708.1101.060.10	100	1/8	26.0	16.0	10	11	11
● GEV-06LLRK 1.8	708.1101.100.10	100	1/8	26.0	14.5	12	11	15
● GEV-08LLRK 1.8	708.1101.160.10	100	1/8	28.5	16.5	14	12	18
● GEV-08LLRK 1.4	708.1101.170.10	100	1/4	32.5	20.5	14	14	26
● GEV-06LRK 1.8	708.1101.100.20	250	1/8	31.0	16.0	14	12	27
● GEV-06LRK 1.4	708.1101.110.20	250	1/4	35.0	19.0	14	14	28
● GEV-06LRK 3.8	708.1101.120.20	250	3/8	34.0	19.0	14	17	34
● GEV-06LRK 1.2	708.1101.125.20	250	1/2	37.0	22.0	14	22	60
● GEV-08LRK 1.8	708.1101.160.20	250	1/8	31.0	16.0	17	14	32
● GEV-08LRK 1.4	708.1101.170.20	250	1/4	35.0	20.0	17	17	40
● GEV-08LRK 3.8	708.1101.180.20	250	3/8	35.0	20.0	17	17	46
● GEV-08LRK 1.2	708.1101.185.20	250	1/2	37.0	22.0	17	22	60
● GEV-10LRK 1.8	708.1101.265.20	250	1/8	32.5	17.0	19	17	38
● GEV-10LRK 1.4	708.1101.270.20	250	1/4	36.5	21.0	19	17	44
● GEV-10LRK 3.8	708.1101.280.20	250	3/8	36.5	21.0	19	17	57
● GEV-10LRK 1.2	708.1101.285.20	250	1/2	38.5	23.0	19	22	70
● GEV-12LRK 1.4	708.1101.380.20	250	1/4	37.5	22.0	22	19	58
● GEV-12LRK 3.8	708.1101.390.20	250	3/8	37.5	22.0	22	19	62
● GEV-12LRK 1.2	708.1101.400.20	250	1/2	39.5	24.0	22	22	80
● GEV-15LRK 3.8	708.1101.532.20	250	3/8	39.0	23.0	27	24	94
● GEV-15LRK 1.2	708.1101.534.20	250	1/2	41.0	25.0	27	24	105
● GEV-18LRK 1.2	708.1101.646.20	160	1/2	42.5	25.5	32	27	145
● GEV-18LRK 3.4	708.1101.648.20	160	3/4	44.5	27.5	32	27	162
● GEV-22LRK 1.2	708.1101.764.20	100	1/2	44.5	27.5	36	32	188
● GEV-22LRK 3.4	708.1101.768.20	100	3/4	46.0	29.5	36	32	192
● GEV-28LRK 1.1	708.1101.850.20	100	1	49.5	32.5	41	41	272
● GEV-35LRK 1.1	708.1101.925.20	100	1	55.0	32.5	50	46	420
● GEV-42LRK 3.2	708.1101.992.20	100	1 1/2	61.5	38.0	60	55	594

Druckangaben gelten in Verbindung mit zylindrischem Innengewinde.

Pressure information applies in connection with parallel female thread.

Datos de presión válidos en combinación con roscas interiores cilíndricas.

Baumaße sind Ungefährmaße bei angezogener Überwurfmutter.

Sizes are approximate dimensions at tightened nut.

Las medidas son aproximadas con la tuerca de unión apretada.

**Gerade Einschraubstutzen**

Abdichtung im Kegengewinde Form C nach DIN 3852-2

**Straight male adaptor connectors**

taper thread sealing form C acc. DIN 3852-2

**Cuerpos para roscar rectos**

cierre hermético con rosca cónica forma C según DIN 3852-2

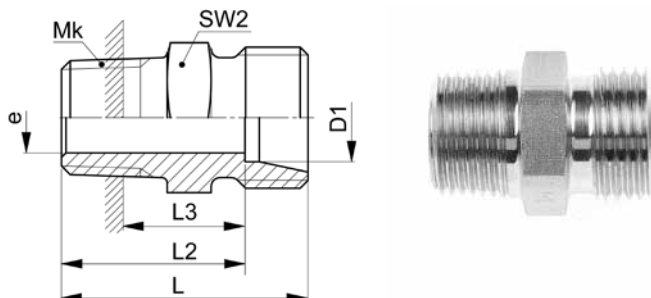

**XGEV-..LMK**

Type-D1 Mk	Mat.-Nr.	PN	Mk	L	L2	L3	SW2	e	g/Stk
Mk=metrisches Gewinde (kegelig)	Mk=metric thread (tapered)								
						Mk=rosca métrica (cónica)			
● XGEV-04LLMK 08x1,0	706.1103.090.10	100	08x1.0	20.0	16.0	10.5	10	3.0	6
● XGEV-06LLMK 10x1,0	706.1103.180.10	100	10x1.0	20.0	14.5	9.0	11	4.0	8
● XGEV-08LLMK 10x1,0	706.1103.230.10	100	10x1.0	22.0	16.5	11.0	12	6.0	10
XGEV-06LMK 08x1,0	706.1103.170.20	250	08x1.0	23.0	16.0	10.5	12	4.0	10
● XGEV-06LMK 10x1,0	706.1103.180.20	250	10x1.0	23.0	16.0	10.5	14	4.0	14
XGEV-06LMK 12x1,5	706.1103.195.20	250	12x1.5	27.0	20.0	11.5	14	4.0	20
● XGEV-08LMK 12x1,5	706.1103.240.20	250	12x1.5	27.0	20.0	11.5	14	6.0	20
XGEV-08LMK 14x1,5	706.1103.245.20	250	14x1.5	27.0	20.0	11.5	17	6.0	22
● XGEV-10LMK 14x1,5	706.1103.280.20	250	14x1.5	28.0	21.0	12.5	17	7.0	24
XGEV-10LMK 16x1,5	706.1103.285.20	250	16x1.5	28.0	21.0	12.5	17	8.0	28
● XGEV-12LMK 16x1,5	706.1103.330.20	250	16x1.5	29.0	22.0	13.1	19	9.0	32
XGEV-12LMK 18x1,5	706.1103.333.20	250	18x1.5	29.0	22.0	13.1	19	9.0	50
● XGEV-15LMK 18x1,5	706.1103.390.20	250	18x1.5	30.0	23.0	14.5	24	11.0	46
● XGEV-18LMK 22x1,5	706.1103.460.20	160	22x1.5	33.0	25.5	17.0	27	14.0	89

Druckangaben gelten in Verbindung mit zylindrischem Innengewinde.

Pressure information applies in connection with parallel female thread.

Datos de presión válidos en combinación con roscas interiores cilíndricas.

Einbaumaß L3 ist abhängig von den Masstoleranzen des Gegenstückes.

Installation size L3 is dependent on the size tolerances of the counterpart.

Distancia de referencia L3 según las tolerancias dimensionales de la contrapieza.

## Gerade Einschraubverschraubungen

Abdichtung durch Kegelfgewinde Form C nach DIN 3852-2

## Straight male adaptor fittings

taper thread sealing form C acc. DIN 3852-2

## Racores para roscar rectos

cierre hermético con rosca cónica forma C según DIN 3852-2

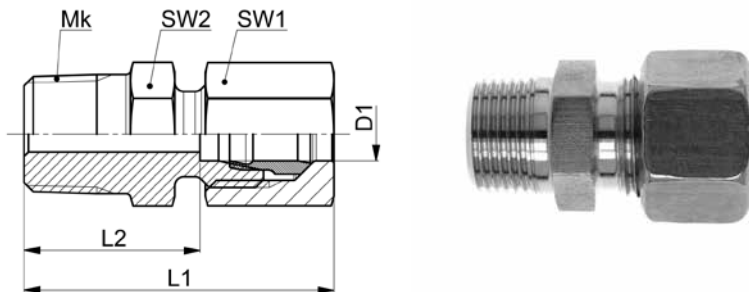

10

### GEV-..LMK

Type-D1 Mk	Mat.-Nr.	PN	Mk	L1	L2	SW1	SW2	g/Stk
Mk=metrisches Gewinde (kegelig)	Mk=metric thread (tapered)						Mk=rosca métrica (cónica)	
● GEV-04LLMK 08x1,0	708.1103.090.10	100	08x1.0	26.0	16.0	10	10	11
● GEV-06LLMK 10x1,0	708.1103.180.10	100	10x1.0	26.0	14.5	12	11	15
● GEV-08LLMK 10x1,0	708.1103.230.10	100	10x1.0	28.0	16.5	14	12	18
● GEV-06LMK 08x1,0	708.1103.170.20	250	08x1.0	31.0	16.0	14	12	22
● GEV-06LMK 10x1,0	708.1103.180.20	250	10x1.0	31.0	16.0	14	14	26
● GEV-06LMK 12x1,5	708.1103.195.20	250	12x1.5	35.0	20.0	14	14	32
● GEV-08LMK 12x1,5	708.1103.240.20	250	12x1.5	35.0	20.0	17	14	35
● GEV-08LMK 14x1,5	708.1103.245.20	250	14x1.5	35.0	20.0	17	17	39
● GEV-10LMK 14x1,5	708.1103.280.20	250	14x1.5	36.0	21.0	19	17	46
● GEV-10LMK 16x1,5	708.1103.285.20	250	16x1.5	36.0	21.0	19	17	50
● GEV-12LMK 16x1,5	708.1103.330.20	250	16x1.5	37.0	22.0	22	19	59
● GEV-12LMK 18x1,5	708.1103.333.20	250	18x1.5	37.0	22.0	22	19	77
● GEV-15LMK 18x1,5	708.1103.390.20	250	18x1.5	38.0	23.0	27	24	91
● GEV-18LMK 22x1,5	708.1103.460.20	160	22x1.5	42.0	25.5	32	27	156

Druckangaben gelten in Verbindung mit zylindrischem Innengewinde.

Pressure information applies in connection with parallel female thread.

Datos de presión válidos en combinación con roscas interiores cilíndricas.

Baumaße sind Ungefährmaße bei angezogener Überwurfmutter.

Sizes are approximate dimensions at tightened nut.

Las medidas son aproximadas con la tuerca de unión apretada.

## Gerade Einschraubstutzen NPT

### Straight male adaptor connectors NPT

### Cuerpos para roscar NPT rectos

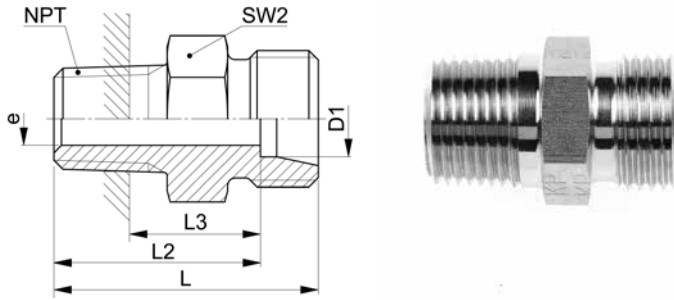

### XGEV-..LNPT

Type-D1 NPT	Mat.-Nr.	PN	NPT	L	L2	L3	SW2	e	g/Stk
NPT=Einschraubgewinde NPT		NPT=tapered male adaptor thread NPT			NPT=rosca de conexión cónica NPT				
XGEV-04LNPT 1.8	706.1102.060.10	100	1/8	22.0	18.0	11.0	11	3.0	8
XGEV-06LNPT 1.8	706.1102.100.10	100	1/8	22.0	16.5	9.5	11	4.5	8
XGEV-08LNPT 1.8	706.1102.160.10	100	1/8	24.0	18.5	11.5	12	6.0	8
XGEV-06LNPT 1.8	706.1102.100.20	500	1/8	24.0	17.0	10.0	12	4.0	12
XGEV-06LNPT 1.4	706.1102.110.20	500	1/4	30.0	23.0	13.0	17	4.0	26
XGEV-06LNPT 3.8	706.1102.120.20	500	3/8	31.0	24.0	14.0	19	4.0	40
XGEV-06LNPT 1.2	706.1102.125.20	500	1/2	36.0	29.0	15.0	22	4.0	70
XGEV-08LNPT 1.8	706.1102.160.20	500	1/8	25.0	18.0	11.0	14	4.5	14
XGEV-08LNPT 1.4	706.1102.170.20	500	1/4	30.0	23.0	13.0	17	6.0	26
XGEV-08LNPT 3.8	706.1102.180.20	500	3/8	31.0	24.0	14.0	19	6.0	38
XGEV-08LNPT 1.2	706.1102.185.20	500	1/2	36.0	29.0	15.0	22	6.0	68
XGEV-10LNPT 1.8	706.1102.265.20	500	1/8	26.0	19.0	12.0	17	4.5	20
XGEV-10LNPT 1.4	706.1102.270.20	500	1/4	31.0	24.0	14.0	17	7.0	26
XGEV-10LNPT 3.8	706.1102.280.20	500	3/8	32.0	25.0	15.0	19	8.0	38
XGEV-10LNPT 1.2	706.1102.285.20	500	1/2	37.0	30.0	16.0	22	8.0	66
XGEV-10LNPT 3.4	706.1102.290.20	500	3/4	38.0	31.0	17.0	27	8.0	93
XGEV-12LNPT 1.8	706.1102.375.20	400	1/8	27.0	20.0	13.0	19	4.5	28
XGEV-12LNPT 1.4	706.1102.380.20	400	1/4	32.0	25.0	15.0	19	7.0	32
XGEV-12LNPT 3.8	706.1102.390.20	400	3/8	32.0	25.0	15.0	19	9.0	37
XGEV-12LNPT 1.2	706.1102.400.20	400	1/2	37.0	30.0	16.0	22	10.0	70
XGEV-12LNPT 3.4	706.1102.405.20	400	3/4	38.0	31.0	17.0	27	10.0	106
XGEV-15LNPT 1.4	706.1102.528.20	400	1/4	33.0	26.0	16.0	24	7.0	46
XGEV-15LNPT 3.8	706.1102.532.20	400	3/8	33.0	26.0	16.0	24	10.0	52
XGEV-15LNPT 1.2	706.1102.534.20	400	1/2	38.0	31.0	17.0	24	12.0	66
XGEV-15LNPT 3.4	706.1102.536.20	400	3/4	39.0	32.0	18.0	27	12.0	106
XGEV-15LNPT 1.1	706.1102.541.20	400	1	45.0	38.0	20.0	36	12.0	158
XGEV-18LNPT 3.8	706.1102.644.20	400	3/8	34.0	26.5	16.5	27	10.0	70
XGEV-18LNPT 1.2	706.1102.646.20	400	1/2	39.0	31.5	17.5	27	14.0	72
XGEV-18LNPT 3.4	706.1102.648.20	400	3/4	39.0	31.5	17.5	27	14.0	102
XGEV-18LNPT 1.1	706.1102.652.20	400	1	45.0	37.5	19.5	36	15.0	194
XGEV-22LNPT 3.8	706.1102.763.20	250	3/8	36.0	28.5	18.5	32	10.0	96
XGEV-22LNPT 1.2	706.1102.764.20	250	1/2	41.0	33.5	19.5	32	14.0	106
XGEV-22LNPT 3.4	706.1102.768.20	250	3/4	41.0	33.5	19.5	32	18.0	104
XGEV-22LNPT 1.1	706.1102.770.20	250	1	47.0	39.5	21.5	36	18.0	194

Fortsetzung auf nächster linker Seite

To be continued on next left page

Continuación próxima página izquierda

**Gerade Einschraubverschraubungen NPT**  
**Straight male adaptor fittings NPT**  
**Racores para roscar rectos NPT**

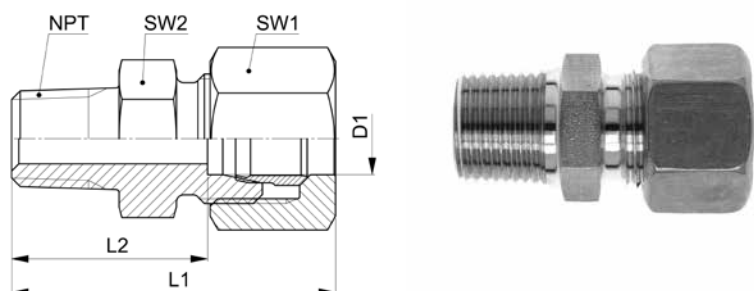

10

**GEV-..LNPT**

Type-D1 NPT	Mat.-Nr.	PN	NPT	L1	L2	SW1	SW2	g/Stk
NPT=Einschraubgewinde NPT		NPT=tapered male adaptor thread NPT			NPT=rosca de conexión cónica NPT			
GEV-04LLNPT 1.8	708.1102.060.10	100	1/8	28.0	18.0	10	11	14
GEV-06LLNPT 1.8	708.1102.100.10	100	1/8	28.0	16.5	12	11	16
GEV-08LLNPT 1.8	708.1102.160.10	100	1/8	30.0	18.5	14	12	19
GEV-06LNPT 1.8	708.1102.100.20	500	1/8	32.0	17.0	14	12	25
GEV-06LNPT 1.4	708.1102.110.20	500	1/4	38.0	23.0	14	17	42
GEV-06LNPT 3.8	708.1102.120.20	500	3/8	39.0	24.0	14	19	51
GEV-06LNPT 1.2	708.1102.125.20	500	1/2	44.0	29.0	14	22	82
GEV-08LNPT 1.8	708.1102.160.20	500	1/8	33.0	18.0	17	14	37
GEV-08LNPT 1.4	708.1102.170.20	500	1/4	38.0	23.0	17	17	43
GEV-08LNPT 3.8	708.1102.180.20	500	3/8	39.0	24.0	17	19	60
GEV-08LNPT 1.2	708.1102.185.20	500	1/2	44.0	29.0	17	22	85
GEV-10LNPT 1.8	708.1102.265.20	500	1/8	34.0	19.0	19	17	40
GEV-10LNPT 1.4	708.1102.270.20	500	1/4	39.0	24.0	19	17	55
GEV-10LNPT 3.8	708.1102.280.20	500	3/8	40.0	25.0	19	19	65
GEV-10LNPT 1.2	708.1102.285.20	500	1/2	45.0	30.0	19	22	85
GEV-10LNPT 3.4	708.1102.290.20	500	3/4	46.0	31.0	19	27	120
GEV-12LNPT 1.8	708.1102.375.20	400	1/8	35.0	20.0	22	19	56
GEV-12LNPT 1.4	708.1102.380.20	400	1/4	40.0	25.0	22	19	59
GEV-12LNPT 3.8	708.1102.390.20	400	3/8	40.0	25.0	22	19	66
GEV-12LNPT 1.2	708.1102.400.20	400	1/2	45.0	30.0	22	22	89
GEV-12LNPT 3.4	708.1102.405.20	400	3/4	46.0	31.0	22	27	134
GEV-15LNPT 1.4	708.1102.528.20	400	1/4	41.0	26.0	27	24	90
GEV-15LNPT 3.8	708.1102.532.20	400	3/8	41.0	26.0	27	24	96
GEV-15LNPT 1.2	708.1102.534.20	400	1/2	46.0	31.0	27	24	115
GEV-15LNPT 3.4	708.1102.536.20	400	3/4	47.0	32.0	27	27	154
GEV-15LNPT 1.1	708.1102.541.20	400	1	53.0	38.0	27	36	178
GEV-18LNPT 3.8	708.1102.644.20	400	3/8	43.0	26.5	32	27	138
GEV-18LNPT 1.2	708.1102.646.20	400	1/2	48.0	31.5	32	27	135
GEV-18LNPT 3.4	708.1102.648.20	400	3/4	48.0	31.5	32	27	170
GEV-18LNPT 1.1	708.1102.652.20	400	1	54.0	37.5	32	36	262
GEV-22LNPT 3.8	708.1102.763.20	250	3/8	45.0	28.5	36	32	200
GEV-22LNPT 1.2	708.1102.764.20	250	1/2	50.0	33.5	36	32	194
GEV-22LNPT 3.4	708.1102.768.20	250	3/4	50.0	33.5	36	32	196
GEV-22LNPT 1.1	708.1102.770.20	250	1	56.0	39.5	36	36	282

Fortsetzung auf nächster rechter Seite

To be continued on next right page

Continuación próxima página derecha

**Gerade Einschraubstutzen NPT**  
**Straight male adaptor connectors NPT**  
**Cuerpos para roscar NPT rectos**

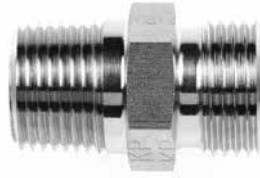
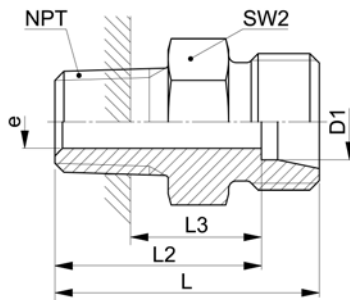

**XGEV-..LNPT**

Type-D1 NPT	Mat.-Nr.	PN	NPT	L	L2	L3	SW2	e	g/Stk
NPT=Einschraubgewinde NPT		NPT=tapered male adaptor thread NPT				NPT=rosca de conexión cónica NPT			
XGEV-28LNPT 3.4	706.1102.845.20	250	3/4	42.0	34.5	20.5	41	18.0	164
XGEV-28LNPT 1.1	706.1102.850.20	250	1	47.0	39.5	21.5	41	23.0	182
XGEV-28LNPT 5.4	706.1102.860.20	250	1 1/4	49.0	41.5	23.5	46	24.0	310
XGEV-35LNPT 1.1	706.1102.925.20	250	1	50.0	39.5	21.5	46	23.0	280
XGEV-35LNPT 5.4	706.1102.944.20	250	1 1/4	51.0	40.5	22.5	46	30.0	285
XGEV-42LNPT 5.4	706.1102.985.20	250	1 1/4	53.0	42.0	24.0	55	30.0	382
XGEV-42LNPT 3.2	706.1102.992.20	250	1 1/2	53.0	42.0	24.0	55	36.0	358

**Gerade Einschraubverschraubungen NPT**  
**Straight male adaptor fittings NPT**  
**Racores para roscar rectos NPT**

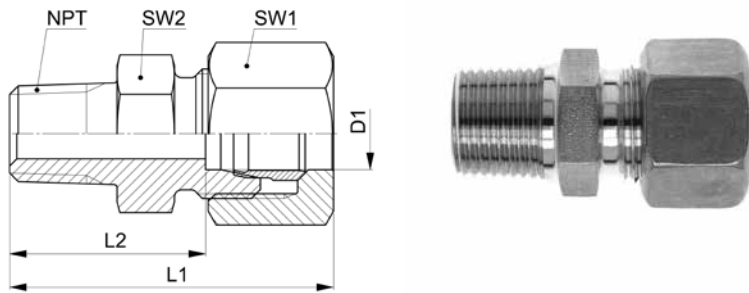

10

**GEV-..LNPT**

Type -D1 NPT	Mat.-Nr.	PN	NPT	L1	L2	SW1	SW2	g/Stk
NPT=Einschraubgewinde NPT		NPT=tapered male adaptor thread NPT			NPT=rosca de conexión cónica NPT			
GEV-28LNPT 3.4	708.1102.845.20	250	3/4	51.0	34.5	41	41	270
GEV-28LNPT 1.1	708.1102.850.20	250	1	56.0	39.5	41	41	285
GEV-28LNPT 5.4	708.1102.860.20	250	1 1/4	58.0	41.5	41	46	416
GEV-35LNPT 1.1	708.1102.925.20	250	1	61.0	39.5	50	46	410
GEV-35LNPT 5.4	708.1102.944.20	250	1 1/4	62.0	40.5	50	46	430
GEV-42LNPT 5.4	708.1102.985.20	250	1 1/4	65.0	42.0	60	55	640
GEV-42LNPT 3.2	708.1102.992.20	250	1 1/2	65.0	42.0	60	55	615

Baumaße sind Ungefährmaße bei angezogener Überwurfmutter.

Sizes are approximate dimensions at tightened nut.

Las medidas son aproximadas con la tuerca de unión apretada.

**Gerade Einschraubstutzen NPT**  
**Straight male adaptor connectors NPT**  
**Cuerpos para roscar NPT rectos**

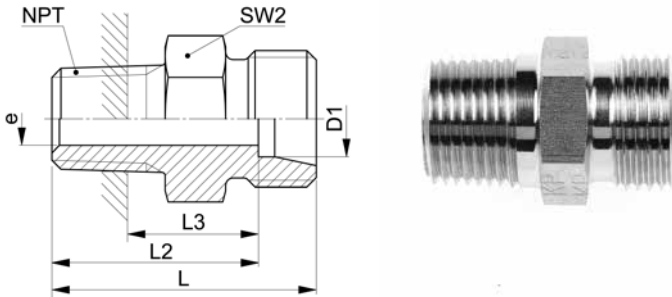

**XGEV-..SNPT**

Type-D1 NPT	Mat.-Nr.	PN	NPT	L	L2	L3	SW2	e	g/Stk
NPT=Einschraubgewinde NPT	NPT=tapered male adaptor thread NPT		NPT=rosca de conexión cónica NPT						
XGEV-06SNPT 1.8	706.1102.100.30	800	1/8	28.0	21.0	14.0	14	4.0	26
XGEV-06SNPT 1.4	706.1102.110.30	800	1/4	35.0	28.0	18.0	17	4.0	36
XGEV-06SNPT 3.8	706.1102.120.30	800	3/8	35.0	28.0	18.0	19	4.0	50
XGEV-06SNPT 1.2	706.1102.125.30	800	1/2	42.0	35.0	21.0	22	4.0	88
XGEV-08SNPT 1.8	706.1102.160.30	800	1/8	30.0	23.0	16.0	17	5.0	29
XGEV-08SNPT 1.4	706.1102.170.30	800	1/4	35.0	28.0	18.0	17	5.0	36
XGEV-08SNPT 3.8	706.1102.180.30	800	3/8	35.0	28.0	18.0	19	5.0	50
XGEV-08SNPT 1.2	706.1102.185.30	800	1/2	42.0	35.0	21.0	22	5.0	88
XGEV-10SNPT 1.4	706.1102.270.30	800	1/4	35.0	27.5	17.5	19	7.0	40
XGEV-10SNPT 3.8	706.1102.280.30	800	3/8	35.0	27.5	17.5	19	7.0	50
XGEV-10SNPT 1.2	706.1102.285.30	800	1/2	42.0	34.5	20.5	22	7.0	86
XGEV-10SNPT 3.4	706.1102.290.30	800	3/4	42.0	34.5	20.5	27	7.0	125
XGEV-12SNPT 1.4	706.1102.380.30	630	1/4	37.0	29.5	19.5	22	7.0	56
XGEV-12SNPT 3.8	706.1102.390.30	630	3/8	37.0	29.5	19.5	22	8.0	62
XGEV-12SNPT 1.2	706.1102.400.30	630	1/2	42.0	34.5	20.5	22	8.0	86
XGEV-12SNPT 3.4	706.1102.405.30	630	3/4	42.0	34.5	20.5	27	8.0	132
XGEV-14SNPT 3.8	706.1102.502.30	630	3/8	39.0	31.0	21.0	24	10.0	68
XGEV-14SNPT 1.2	706.1102.504.30	630	1/2	44.0	36.0	22.0	24	10.0	92
XGEV-14SNPT 3.4	706.1102.506.30	630	3/4	44.0	36.0	22.0	27	10.0	130
XGEV-14SNPT 1.1	706.1102.510.30	630	1	51.0	43.0	25.0	36	10.0	180
XGEV-16SNPT 3.8	706.1102.564.30	630	3/8	39.0	30.5	20.5	27	9.0	82
XGEV-16SNPT 1.2	706.1102.566.30	630	1/2	44.0	35.5	21.5	27	12.0	94
XGEV-16SNPT 3.4	706.1102.568.30	630	3/4	44.0	35.5	21.5	27	12.0	126
XGEV-16SNPT 1.1	706.1102.570.30	630	1	51.0	42.5	24.5	36	12.0	254
XGEV-20SNPT 1.2	706.1102.706.30	630	1/2	48.0	37.5	23.5	32	12.0	148
XGEV-20SNPT 3.4	706.1102.708.30	420	3/4	48.0	37.5	23.5	32	16.0	154
XGEV-20SNPT 1.1	706.1102.712.30	420	1	53.0	42.5	24.5	36	16.0	248
XGEV-25SNPT 1.2	706.1102.800.30	420	1/2	52.0	40.0	26.0	41	12.0	210
XGEV-25SNPT 3.4	706.1102.805.30	420	3/4	52.0	40.0	26.0	41	16.0	258
XGEV-25SNPT 1.1	706.1102.810.30	420	1	57.0	45.0	27.0	41	20.0	286
XGEV-25SNPT 5.4	706.1102.815.30	420	1 1/4	58.0	46.0	28.0	46	20.0	411
XGEV-25SNPT 3.2	706.1102.820.30	420	1 1/2	58.0	46.0	28.0	50	20.0	490

Fortsetzung auf nächster linker Seite

To be continued on next left page

Continuación próxima página izquierda

**Gerade Einschraubverschraubungen NPT**  
**Straight male adaptor fittings NPT**  
**Racores para roscar rectos NPT**

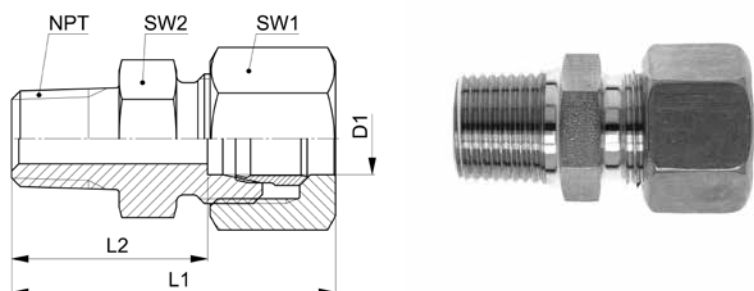

10

**GEV-..SNPT**

Type-D1 NPT	Mat.-Nr.	PN	NPT	L1	L2	SW1	SW2	g/Stk
NPT=Einschraubgewinde NPT		NPT=tapered male adaptor thread NPT			NPT=rosca de conexión cónica NPT			
GEV-06SNPT 1.8	708.1102.100.30	800	1/8	36.0	21.0	17	14	45
GEV-06SNPT 1.4	708.1102.110.30	800	1/4	43.0	28.0	17	17	55
GEV-06SNPT 3.8	708.1102.120.30	800	3/8	43.0	28.0	17	19	70
GEV-06SNPT 1.2	708.1102.125.30	800	1/2	50.0	35.0	17	22	93
GEV-08SNPT 1.8	708.1102.160.30	800	1/8	38.0	23.0	19	17	48
GEV-08SNPT 1.4	708.1102.170.30	800	1/4	43.0	28.0	19	17	60
GEV-08SNPT 3.8	708.1102.180.30	800	3/8	43.0	28.0	19	19	74
GEV-08SNPT 1.2	708.1102.185.30	800	1/2	50.0	35.0	19	22	108
GEV-10SNPT 1.4	708.1102.270.30	800	1/4	44.0	27.5	22	19	71
GEV-10SNPT 3.8	708.1102.280.30	800	3/8	44.0	27.5	22	19	86
GEV-10SNPT 1.2	708.1102.285.30	800	1/2	51.0	34.5	22	22	104
GEV-10SNPT 3.4	708.1102.290.30	800	3/4	51.0	34.5	22	27	154
GEV-12SNPT 1.4	708.1102.380.30	630	1/4	46.0	29.5	24	22	96
GEV-12SNPT 3.8	708.1102.390.30	630	3/8	46.0	29.5	24	22	100
GEV-12SNPT 1.2	708.1102.400.30	630	1/2	51.0	34.5	24	22	121
GEV-12SNPT 3.4	708.1102.405.30	630	3/4	51.0	34.5	24	27	170
GEV-14SNPT 3.8	708.1102.502.30	630	3/8	49.0	31.0	27	24	125
GEV-14SNPT 1.2	708.1102.504.30	630	1/2	54.0	36.0	27	24	160
GEV-14SNPT 3.4	708.1102.506.30	630	3/4	54.0	36.0	27	27	180
GEV-14SNPT 1.1	708.1102.510.30	630	1	61.0	43.0	27	36	230
GEV-16SNPT 3.8	708.1102.564.30	630	3/8	49.0	30.5	30	27	152
GEV-16SNPT 1.2	708.1102.566.30	630	1/2	54.0	35.5	30	27	170
GEV-16SNPT 3.4	708.1102.568.30	630	3/4	54.0	35.5	30	27	196
GEV-16SNPT 1.1	708.1102.570.30	630	1	61.0	42.5	30	36	324
GEV-20SNPT 1.2	708.1102.706.30	420	1/2	59.0	37.5	36	32	246
GEV-20SNPT 3.4	708.1102.708.30	420	3/4	59.0	37.5	36	32	268
GEV-20SNPT 1.1	708.1102.712.30	420	1	64.0	42.5	36	36	360
GEV-25SNPT 1.2	708.1102.800.30	420	1/2	64.0	40.0	46	41	421
GEV-25SNPT 3.4	708.1102.805.30	420	3/4	64.0	40.0	46	41	474
GEV-25SNPT 1.1	708.1102.810.30	420	1	69.0	45.0	46	41	503
GEV-25SNPT 5.4	708.1102.815.30	420	1 1/4	70.0	46.0	46	46	654
GEV-25SNPT 3.2	708.1102.820.30	420	1 1/2	70.0	46.0	46	50	714

Fortsetzung auf nächster rechter Seite

To be continued on next right page

Continuación próxima página derecha

**Gerade Einschraubstutzen NPT**  
**Straight male adaptor connectors NPT**  
**Cuerpos para roscar NPT rectos**

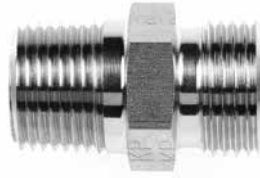
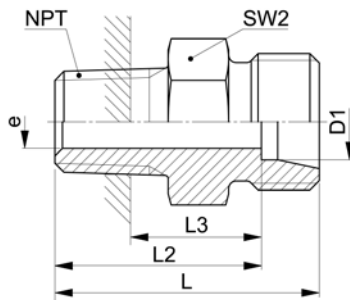

**XGEV-..SNPT**

Type -D1 NPT	Mat.-Nr.	PN	NPT	L	L2	L3	SW2	e	g/Stk
NPT=Einschraubgewinde NPT	NPT=tapered male adaptor thread NPT		NPT=rosca de conexión cónica NPT						
XGEV-30SNPT 3.4	706.1102.895.30	420	3/4	54.0	40.5	26.5	46	16.0	326
XGEV-30SNPT 1.1	706.1102.900.30	420	1	59.0	45.5	27.5	46	20.0	354
XGEV-30SNPT 5.4	706.1102.902.30	420	1 1/4	60.0	46.5	28.5	46	25.0	410
XGEV-30SNPT 3.2	706.1102.905.30	420	1 1/2	60.0	46.5	28.5	50	25.0	536
XGEV-38SNPT 1.1	706.1102.960.30	420	1	64.0	48.0	30.0	55	20.0	588
XGEV-38SNPT 5.4	706.1102.954.30	420	1 1/4	65.0	49.0	31.0	55	25.0	626
XGEV-38SNPT 3.2	706.1102.953.30	420	1 1/2	65.0	49.0	31.0	55	32.0	586

**Gerade Einschraubverschraubungen NPT**  
**Straight male adaptor fittings NPT**  
**Racores para roscar rectos NPT**

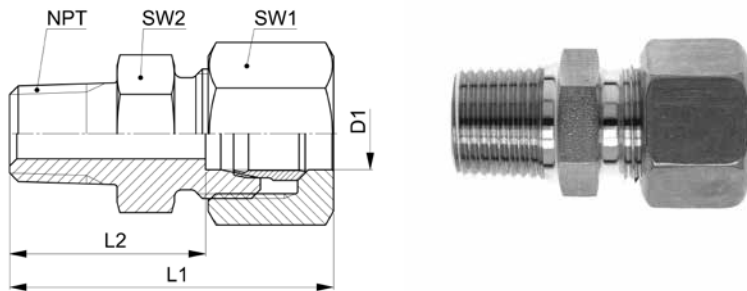

10

**GEV-..SNPT**

Type -D1 NPT	Mat.-Nr.	PN	NPT	L1	L2	SW1	SW2	g/Stk
NPT=Einschraubgewinde NPT		NPT=tapered male adaptor thread NPT				NPT=rosca de conexión cónica NPT		
GEV-30SNPT 3.4	708.1102.895.30	420	3/4	67.0	40.5	50	46	536
GEV-30SNPT 1.1	708.1102.900.30	420	1	72.0	45.5	50	46	590
GEV-30SNPT 5.4	708.1102.902.30	420	1 1/4	73.0	46.5	50	46	650
GEV-30SNPT 3.2	708.1102.905.30	420	1 1/2	73.0	46.5	50	50	786
GEV-38SNPT 1.1	708.1102.960.30	420	1	79.0	48.0	60	55	955
GEV-38SNPT 5.4	708.1102.954.30	420	1 1/4	80.0	49.0	60	55	955
GEV-38SNPT 3.2	708.1102.953.30	420	1 1/2	80.0	49.0	60	55	935

Baumaße sind Ungefährmaße bei angezogener Überwurfmutter.

Sizes are approximate dimensions at tightened nut.

Las medidas son aproximadas con la tuerca de unión apretada.

## Winkel-Einschraubstutzen

Abdichtung durch Dichtkante Form B nach DIN 3852-2

## Male adaptor elbow connectors

sealing edge form B acc. DIN 3852-2

## Cuerpos para roscar en codo

cierre hermético mediante borde de obturación forma B según DIN 3852-2

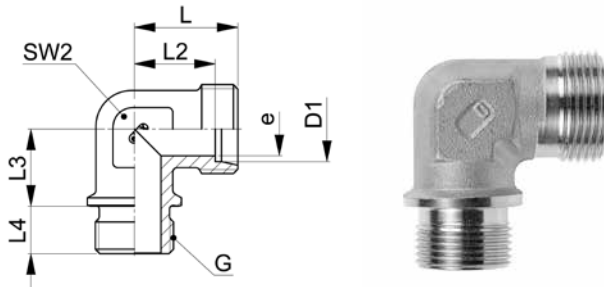

### XWEV-..LR/SR

Type-D1 G	Mat.-Nr.	G	PN	L	L2	L3	L4	SW2	e	g/Stk
G=Rohrgewinde (zylindrisch)		G=BSP thread (parallel)								
								G=rosca de conexión (cilíndrica)		
● XWEV-22LR 3.4	706.2406.768.20	3/4	250	35.0	27.5	26.0	16.0	27	18.0	190
● XWEV-28LR 1.1	706.2406.850.20	1	250	38.0	30.5	30.0	18.0	36	23.0	333
● XWEV-35LR 5.4	706.2406.944.20	1 1/4	250	45.0	34.5	34.0	20.0	41	30.0	498
● XWEV-42LR 3.2	706.2406.992.20	1 1/2	250	51.0	40.0	39.0	22.0	50	36.0	722
● XWEV-20SR 3.4	706.2406.704.30	3/4	420	37.0	26.5	26.0	16.0	27	16.0	228
● XWEV-25SR 1.1	706.2406.810.30	1	420	42.0	30.0	30.0	18.0	36	20.0	415
● XWEV-30SR 5.4	706.2406.902.30	1 1/4	420	49.0	35.5	34.0	20.0	41	25.0	670
● XWEV-38SR 3.2	706.2406.953.30	1 1/2	420	57.0	41.0	39.0	22.0	50	32.0	960

## Winkel-Einschraubverschraubungen

Abdichtung durch Dichtkante Form B nach DIN 3852-2

## Male adaptor elbow fittings

sealing edge form B acc. DIN 3852-2

## Racores para roscar en codo

cierre hermético mediante borde de obturación forma B según DIN 3852-2

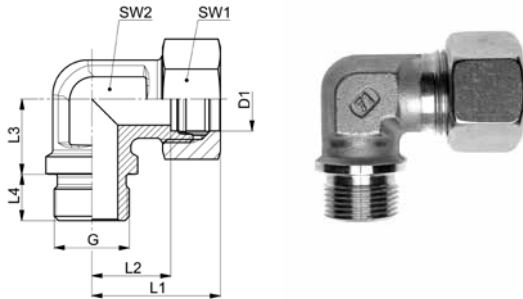

10

### WEV-..LR/SR

Type-D1 G	Mat.-Nr.	G	PN	L1	L2	L3	L4	SW1	SW2	g/Stk
G=Rohrgewinde (zylindrisch)		G=BSP thread (parallel)								
						G=rosca de conexión (cilíndrica)				
● WEV-22LR 3.4	708.2406.768.20	3/4	250	44.0	27.5	26.0	16.0	36	27	267
● WEV-28LR 1.1	708.2406.850.20	1	250	47.0	30.5	30.0	18.0	41	36	418
● WEV-35LR 5.4	708.2406.944.20	1 1/4	250	56.0	34.5	34.0	20.0	50	41	630
● WEV-42LR 3.2	708.2406.992.20	1 1/2	250	63.0	40.0	39.0	22.0	60	50	947
● WEV-20SR 3.4	708.2406.704.30	3/4	420	48.0	26.5	26.0	16.0	36	27	329
● WEV-25SR 1.1	708.2406.810.30	1	420	54.0	30.0	30.0	18.0	46	36	631
● WEV-30SR 5.4	708.2406.902.30	1 1/4	420	62.0	35.5	34.0	20.0	50	41	874
● WEV-38SR 3.2	708.2406.953.30	1 1/2	420	72.0	41.0	39.0	22.0	60	50	1225

Baumaße sind Ungefährmaße bei angezogener Überwurfmutter.

Sizes are approximate dimensions at tightened nut.

Las medidas son aproximadas con la tuerca de unión apretada.

**Winkel-Einschraubstutzen**

Abdichtung im Kegengewinde Form C nach DIN 3852-2

**Male adaptor elbow connectors**

taper thread sealing form C acc. DIN 3852-2

**Cuerpos para roscar en codo**

cierre hermético con rosca cónica forma C según DIN 3852-2

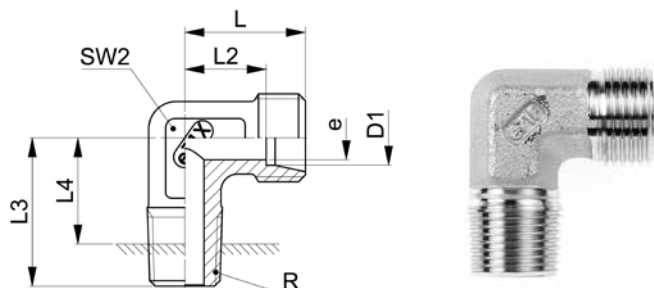

**XWEV-..LRK**

Type-D1 R	Mat.-Nr.	PN	R	L	L2	L3	L4	SW2	e	g/Stk
R=Rohrgewinde (kegelig)		R=BSP thread (tapered)				R=rosca para tubos (cónica)				
● XWEV-04LLRK 1.8	706.2401.060.10	100	1/8	15.0	11.0	15.0	10.0	9	3.0	11
● XWEV-06LLRK 1.8	706.2401.100.10	100	1/8	15.0	9.5	15.0	10.0	9	4.5	10
● XWEV-08LLRK 1.8	706.2401.160.10	100	1/8	17.0	11.5	20.0	15.0	12	6.0	16
● XWEV-06LRK 1.8	706.2401.100.20	250	1/8	19.0	12.0	20.0	15.0	12	4.0	23
XWEV-06LRK 1.4	706.2401.110.20	250	1/4	19.0	12.0	26.0	18.0	12	4.0	30
XWEV-06LRK 3.8	706.2401.120.20	250	3/8	21.0	14.0	28.0	20.0	14	4.0	56
XWEV-08LRK 1.8	706.2401.160.20	250	1/8	21.0	14.0	26.0	21.0	12	4.0	29
● XWEV-08LRK 1.4	706.2401.170.20	250	1/4	21.0	14.0	26.0	18.0	12	6.0	32
XWEV-08LRK 3.8	706.2401.180.20	250	3/8	22.0	15.0	27.0	19.0	14	6.0	44
XWEV-08LRK 1.2	706.2401.185.20	250	1/2	26.0	19.0	30.0	20.0	17	6.0	87
● XWEV-10LRK 1.8	706.2401.265.20	250	1/8	22.0	15.0	26.0	21.0	14	4.0	38
● XWEV-10LRK 1.4	706.2401.270.20	250	1/4	22.0	15.0	27.0	19.0	14	7.0	40
XWEV-10LRK 3.8	706.2401.280.20	250	3/8	22.0	15.0	27.0	19.0	14	8.0	47
XWEV-10LRK 1.2	706.2401.285.20	250	1/2	28.0	21.0	32.0	22.0	19	8.0	110
XWEV-12LRK 1.4	706.2401.380.20	250	1/4	24.0	17.0	28.0	20.0	17	6.0	55
● XWEV-12LRK 3.8	706.2401.390.20	250	3/8	24.0	17.0	28.0	20.0	17	9.0	57
XWEV-12LRK 1.2	706.2401.400.20	250	1/2	28.0	21.0	32.0	22.0	17	10.0	82
XWEV-15LRK 3.8	706.2401.532.20	250	3/8	28.0	21.0	28.0	20.0	19	9.0	86
● XWEV-15LRK 1.2	706.2401.534.20	250	1/2	28.0	21.0	34.0	24.0	19	11.0	102
● XWEV-18LRK 1.2	706.2401.646.20	160	1/2	31.0	23.5	36.0	26.0	24	14.0	124
XWEV-18LRK 3.4	706.2401.648.20	160	3/4	31.0	23.5	34.0	22.0	24	15.0	145
XWEV-22LRK 3.4	706.2401.768.20	100	3/4	35.0	27.5	42.0	30.0	27	18.0	188

Druckangaben gelten in Verbindung mit zylindrischem Innengewinde.

Pressure information applies in connection with parallel female thread.

Datos de presión válidos en combinación con roscas interiores cilíndricas.

Einbaumaß L4 ist abhängig von den Masstoleranzen des Gegenstückes.

Installation size L4 is dependent on the size tolerances of the counterpart.

Distancia de referencia L4 según las tolerancias dimensionales de la contrapieza.

## Winkel-Einschraubverschraubungen

Abdichtung im Kegelgewinde Form C nach DIN 3852-2

## Male adaptor elbow fittings

taper thread sealing form C acc. DIN 3852-2

## Racores para roscar en codo

cierre hermético con rosca cónica forma C según DIN 3852-2

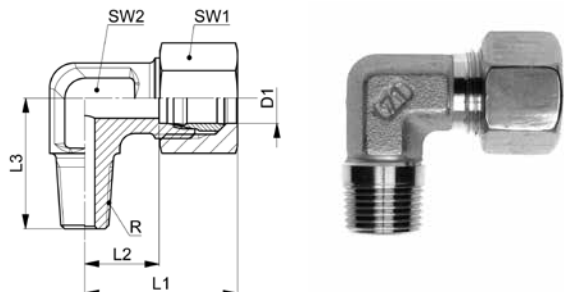

### WEV-..LRK

Type-D1 R	Mat.-Nr.	PN	R	L1	L2	L3	SW1	SW2	g/Stk
R=Rohrgewinde (kegelig)		R=BSP thread (tapered)				R=rosca para tubos (cónica)			
● WEV-04LLRK 1.8	708.2401.060.10	100	1/8	21.0	11.0	15.0	10	9	21
● WEV-06LLRK 1.8	708.2401.100.10	100	1/8	21.0	9.5	15.0	12	9	27
● WEV-08LLRK 1.8	708.2401.160.10	100	1/8	23.5	11.5	20.0	14	12	32
● WEV-06LRK 1.8	708.2401.100.20	250	1/8	27.0	12.0	20.0	14	12	34
WEV-06LRK 1.4	708.2401.110.20	250	1/4	27.0	12.0	26.0	14	12	57
WEV-06LRK 3.8	708.2401.120.20	250	3/8	29.0	14.0	28.0	14	14	58
WEV-08LRK 1.8	708.2401.160.20	250	1/8	29.0	14.0	26.0	17	12	53
● WEV-08LRK 1.4	708.2401.170.20	250	1/4	29.0	14.0	26.0	17	12	60
WEV-08LRK 3.8	708.2401.180.20	250	3/8	30.0	15.0	27.0	17	14	82
WEV-08LRK 1.2	708.2401.185.20	250	1/2	34.0	19.0	30.0	17	17	95
WEV-10LRK 1.8	708.2401.265.20	250	1/8	30.5	15.0	26.0	19	14	64
● WEV-10LRK 1.4	708.2401.270.20	250	1/4	30.5	15.0	27.0	19	14	66
WEV-10LRK 3.8	708.2401.280.20	250	3/8	30.5	15.0	27.0	19	14	70
WEV-10LRK 1.2	708.2401.285.20	250	1/2	36.5	21.0	32.0	19	19	90
WEV-12LRK 1.4	708.2401.380.20	250	1/4	32.5	17.0	28.0	22	17	74
● WEV-12LRK 3.8	708.2401.390.20	250	3/8	32.5	17.0	28.0	22	17	75
WEV-12LRK 1.2	708.2401.400.20	250	1/2	36.5	21.0	32.0	22	17	110
WEV-15LRK 3.8	708.2401.532.20	250	3/8	37.0	21.0	28.0	27	19	134
● WEV-15LRK 1.2	708.2401.534.20	250	1/2	37.5	21.0	34.0	27	19	216
● WEV-18LRK 1.2	708.2401.646.20	160	1/2	40.5	23.5	36.0	32	24	273
WEV-18LRK 3.4	708.2401.648.20	160	3/4	40.5	23.5	34.0	32	24	233
WEV-22LRK 3.4	708.2401.768.20	100	3/4	44.5	27.5	42.0	36	27	295

Druckangaben gelten in Verbindung mit zylindrischem Innengewinde.

Pressure information applies in connection with parallel female thread.

Datos de presión válidos en combinación con roscas interiores cilíndricas.

Baumaße sind Ungefährmaße bei angezogener Überwurfmutter.

Sizes are approximate dimensions at tightened nut.

Las medidas son aproximadas con la tuerca de unión apretada.

**Winkel-Einschraubstutzen**

Abdichtung im Kegengewinde Form C nach DIN 3852-2

**Male adaptor elbow connectors**

taper thread sealing form C acc. DIN 3852-2

**Cuerpos para roscar en codo**

cierre hermético con rosca cónica forma C según DIN 3852-2

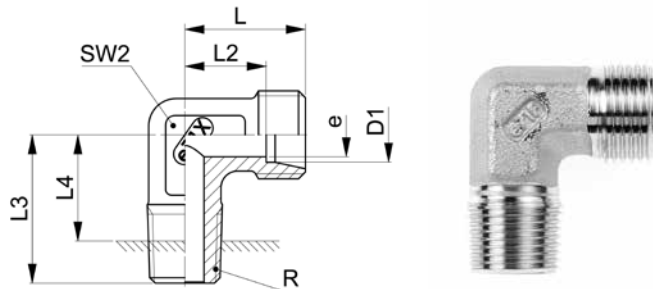

**XWEV-..SRK**

Type-D1 R	Mat.-Nr.	PN	R	L	L2	L3	L4	SW2	e	g/Stk
R=Rohrgewinde (kegelig)		R=BSP thread (tapered)				R=rosca para tubos (cónica)				
XWEV-06SRK 1.8	706.2401.100.30	400	1/8	23.0	16.0	26.0	21.0	12	4.0	35
● XWEV-06SRK 1.4	706.2401.110.30	400	1/4	23.0	16.0	26.0	18.0	12	4.0	37
XWEV-06SRK 3.8	706.2401.120.30	400	3/8	23.0	16.0	28.0	20.0	14	4.0	55
XWEV-06SRK 1.2	706.2401.125.30	400	1/2	23.0	16.0	29.0	19.0	17	4.0	78
● XWEV-08SRK 1.4	706.2401.170.30	400	1/4	24.0	17.0	27.0	19.0	14	5.0	53
XWEV-08SRK 3.8	706.2401.180.30	400	3/8	24.0	17.0	27.0	19.0	14	5.0	58
XWEV-08SRK 1.2	706.2401.185.30	400	1/2	26.0	19.0	30.0	20.0	17	6.0	91
XWEV-10SRK 1.4	706.2401.270.30	400	1/4	25.0	17.5	27.0	19.0	17	6.0	63
● XWEV-10SRK 3.8	706.2401.280.30	400	3/8	25.0	17.5	28.0	20.0	17	7.0	71
XWEV-10SRK 1.2	706.2401.285.30	400	1/2	25.0	17.5	32.0	22.0	19	7.0	110
● XWEV-12SRK 3.8	706.2401.390.30	400	3/8	29.0	21.5	28.0	20.0	17	8.0	83
XWEV-12SRK 1.2	706.2401.400.30	400	1/2	29.0	21.5	32.0	22.0	17	8.0	96
XWEV-14SRK 3.8	706.2401.502.30	400	3/8	30.0	22.0	32.0	24.0	19	10.0	99
XWEV-14SRK 1.2	706.2401.504.30	400	1/2	30.0	22.0	32.0	22.0	19	10.0	113
● XWEV-16SRK 1.2	706.2401.566.30	400	1/2	33.0	24.5	32.0	22.0	24	12.0	131

Druckangaben gelten in Verbindung mit zylindrischem Innengewinde.

Pressure information applies in connection with parallel female thread.

Datos de presión válidos en combinación con roscas interiores cilíndricas.

Einbaumaß L4 ist abhängig von den Masstoleranzen des Gegenstückes.

Installation size L4 is dependent on the size tolerances of the counterpart.

Distancia de referencia L4 según las tolerancias dimensionales de la contrapieza.

## Winkel-Einschraubverschraubungen

Abdichtung im Kegelgewinde Form C nach DIN 3852-2

## Male adaptor elbow fittings

taper thread sealing form C acc. DIN 3852-2

## Racores para roscar en codo

cierre hermético con rosca cónica forma C según DIN 3852-2

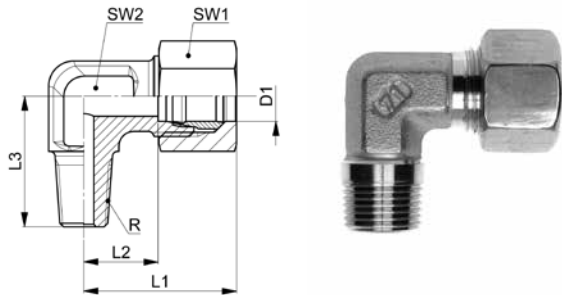

10

### WEV-..SRK

Type-D1 R	Mat.-Nr.	PN	R	L1	L2	L3	SW1	SW2	g/Stk
R=Rohrgewinde (kegelig)		R=BSP thread (tapered)				R=rosca para tubos (cónica)			
WEV-06SRK 1.8	708.2401.100.30	400	1/8	31.0	16.0	26.0	17	12	59
● WEV-06SRK 1.4	708.2401.110.30	400	1/4	31.0	16.0	26.0	17	12	61
WEV-06SRK 3.8	708.2401.120.30	400	3/8	31.0	16.0	28.0	17	14	80
WEV-06SRK 1.2	708.2401.125.30	400	1/2	31.0	16.0	29.0	17	17	101
● WEV-08SRK 1.4	708.2401.170.30	400	1/4	32.0	17.0	27.0	19	14	79
WEV-08SRK 3.8	708.2401.180.30	400	3/8	32.0	17.0	27.0	19	14	85
WEV-08SRK 1.2	708.2401.185.30	400	1/2	34.0	19.0	30.0	19	17	102
WEV-10SRK 1.4	708.2401.270.30	400	1/4	34.5	17.5	27.0	22	17	92
● WEV-10SRK 3.8	708.2401.280.30	400	3/8	34.5	17.5	28.0	22	17	95
WEV-10SRK 1.2	708.2401.285.30	400	1/2	34.5	17.5	32.0	22	17	131
● WEV-12SRK 3.8	708.2401.390.30	400	3/8	38.5	21.5	28.0	24	17	115
WEV-12SRK 1.2	708.2401.400.30	400	1/2	38.5	21.5	32.0	24	17	130
WEV-14SRK 3.8	708.2401.502.30	400	3/8	40.5	22.0	32.0	27	19	147
WEV-14SRK 1.2	708.2401.504.30	400	1/2	40.5	22.0	32.0	27	19	158
● WEV-16SRK 1.2	708.2401.566.30	400	1/2	44.0	24.5	32.0	30	24	200

Druckangaben gelten in Verbindung mit zylindrischem Innengewinde.

Pressure information applies in connection with parallel female thread.

Datos de presión válidos en combinación con roscas interiores cilíndricas.

Baumaße sind Ungefährmaße bei angezogener Überwurfmutter.

Sizes are approximate dimensions at tightened nut.

Las medidas son aproximadas con la tuerca de unión apretada.

**Winkel-Einschraubstutzen**

Abdichtung im Kegengewinde Form C nach DIN 3852-2

**Male adaptor elbow connectors**

taper thread sealing form C acc. DIN 3852-2

**Cuerpos para roscar en codo**

cierre hermético con rosca cónica forma C según DIN 3852-2

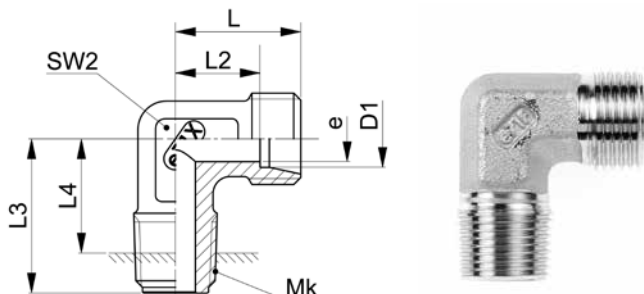

**XWEV-..LMK/SMK**

Type-D1 Mk	Mat.-Nr.	PN	Mk	L	L2	L3	L4	SW2	e	g/Stk
Mk=metrisches Gewinde (kegelig)	Mk=metric thread (tapered)	Mk=rosca métrica (cónica)								
● XWEV-04LLMK 08x1,0	706.2403.090.10	100	08x1.0	15.0	11.0	17.0	11.5	9	3.0	12
XWEV-06LLMK 08x1,0	706.2403.170.10	100	08x1.0	15.0	9.5	17.0	11.5	9	3.5	11
● XWEV-06LLMK 10x1,0	706.2403.180.10	100	10x1.0	15.0	9.5	17.0	11.5	9	4.5	12
XWEV-08LLMK 08x1,0	706.2403.225.10	100	08x1.0	17.0	11.5	17.0	11.5	12	3.5	16
● XWEV-08LLMK 10x1,0	706.2403.230.10	250	10x1.0	17.0	11.5	20.0	14.5	12	6.0	17
● XWEV-06LMK 10x1,0	706.2403.180.20	250	10x1.0	19.0	12.0	20.0	14.5	12	4.0	24
● XWEV-08LMK 12x1,5	706.2403.240.20	250	12x1.5	21.0	14.0	26.0	17.5	12	6.0	29
● XWEV-10LMK 14x1,5	706.2403.278.20	250	14x1.5	22.0	15.0	27.0	18.5	14	7.0	42
● XWEV-12LMK 16x1,5	706.2403.330.20	250	16x1.5	24.0	17.0	28.0	19.5	17	9.0	55
● XWEV-15LMK 18x1,5	706.2403.390.20	250	18x1.5	28.0	21.0	32.0	23.5	19	10.0	92
● XWEV-18LMK 22x1,5	706.2403.460.20	160	22x1.5	31.0	23.5	36.0	27.5	24	14.0	131
● XWEV-06SMK 12x1,5	706.2403.190.30	400	12x1.5	23.0	16.0	26.0	17.5	12	4.0	38
● XWEV-08SMK 14x1,5	706.2403.245.30	400	14x1.5	24.0	17.0	27.0	18.5	14	5.0	54
● XWEV-10SMK 16x1,5	706.2403.285.30	400	16x1.5	25.0	17.5	28.0	19.5	17	7.0	69
● XWEV-12SMK 18x1,5	706.2403.333.30	400	18x1.5	29.0	21.5	28.0	19.5	17	8.0	86
XWEV-14SMK 20x1,5	706.2403.382.30	400	20x1.5	30.0	22.0	32.0	23.5	19	10.0	110

Druckangaben gelten in Verbindung mit zylindrischem Innengewinde.

Pressure information applies in connection with parallel female thread.

Datos de presión válidos en combinación con roscas interiores cilíndricas.

Einbaumaß L4 ist abhängig von den Masstoleranzen des Gegenstückes.

Installation size L4 is dependent on the size tolerances of the counterpart.

Distancia de referencia L4 según las tolerancias dimensionales de la contrapieza.

## Winkel-Einschraubverschraubungen

Abdichtung im Kegelgewinde Form C nach DIN 3852-2

## Male adaptor elbow fittings

taper thread sealing form C acc. DIN 3852-2

## Racores para roscar en codo

cierre hermético con rosca cónica forma C según DIN 3852-2

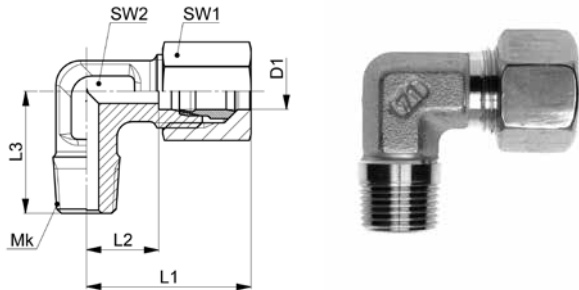

10

### WEV-..LMK/SMK

Type-D1 Mk	Mat.-Nr.	PN	Mk	L1	L2	L3	SW1	SW2	g/Stk
Mk=metrisches Gewinde (kegelig)	Mk=metric thread (tapered)								
						Mk=rosca métrica (cónica)			
● WEV-04LLMK 08x1,0	708.2403.090.10	100	08x1.0	21.0	11.0	17.0	10	9	17
WEV-06LLMK 08x1,0	708.2403.170.10	100	08x1.0	21.0	9.5	17.0	12	9	18
● WEV-06LLMK 10x1,0	708.2403.180.10	100	10x1.0	21.0	9.5	17.0	12	9	20
WEV-08LLMK 08x1,0	708.2403.225.10	100	08x1.0	23.5	11.5	17.0	14	12	22
● WEV-08LLMK 10x1,0	708.2403.230.10	100	10x1.0	23.5	11.5	20.0	14	12	24
● WEV-06LMK 10x1,0	708.2403.180.20	250	10x1.0	27.0	12.0	20.0	14	12	32
● WEV-08LMK 12x1,5	708.2403.240.20	250	12x1.5	29.0	14.0	26.0	17	12	43
● WEV-10LMK 14x1,5	708.2403.278.20	250	14x1.5	30.5	15.0	27.0	19	14	61
● WEV-12LMK 16x1,5	708.2403.330.20	250	16x1.5	32.5	17.0	28.0	22	17	80
● WEV-15LMK 18x1,5	708.2403.390.20	250	18x1.5	37.0	21.0	32.0	27	19	136
● WEV-18LMK 22x1,5	708.2403.460.20	160	22x1.5	40.5	23.5	36.0	32	24	188
● WEV-06SMK 12x1,5	708.2403.190.30	400	12x1.5	31.0	16.0	26.0	17	12	55
● WEV-08SMK 14x1,5	708.2403.245.30	400	14x1.5	32.0	17.0	27.0	19	14	70
● WEV-10SMK 16x1,5	708.2403.285.30	400	16x1.5	34.5	17.5	28.0	22	17	98
● WEV-12SMK 18x1,5	708.2403.333.30	400	18x1.5	38.5	21.5	28.0	24	17	118
WEV-14SMK 20x1,5	708.2403.382.30	400	20x1.5	40.5	22.0	32.0	27	19	154

Druckangaben gelten in Verbindung mit zylindrischem Innengewinde.

Pressure information applies in connection with parallel female thread.

Datos de presión válidos en combinación con roscas interiores cilíndricas.

Baumaße sind Ungefährmaße bei angezogener Überwurfmutter.

Sizes are approximate dimensions at tightened nut.

Las medidas son aproximadas con la tuerca de unión apretada.

**Winkel-Einschraubstutzen NPT**

**Male adaptor elbow connectors NPT**

**Cuerpos para roscar en codo NPT**

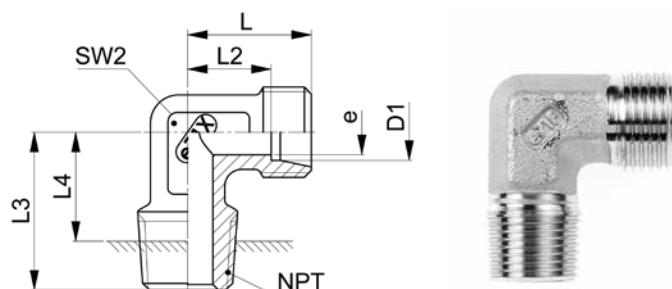

**XWEV-..LNPT**

Type-D1 NPT	Mat.-Nr.	PN	NPT	L	L2	L3	L4	SW2	e	g/Stk
NPT=Einschraubgewinde NPT		NPT=tapered male adaptor thread NPT			NPT=rosca de conexión cónica NPT					
XWEV-04LNPT 1.8	706.2402.060.10	100	1/8	15.0	11.0	17.0	8.0	9	3.0	13
XWEV-06LNPT 1.8	706.2402.100.10	100	1/8	15.0	9.5	17.0	8.0	9	4.5	12
XWEV-08LNPT 1.8	706.2402.160.10	100	1/8	17.0	11.5	20.0	10.0	12	6.0	17
XWEV-06LNPT 1.8	706.2402.100.20	500	1/8	19.0	12.0	20.0	12.0	12	4.0	22
XWEV-06LNPT 1.4	706.2402.110.20	500	1/4	17.0	10.0	25.5	7.0	12	4.0	26
XWEV-06LNPT 3.8	706.2402.120.20	500	3/8	21.0	14.0	28.0	11.0	14	4.0	44
XWEV-08LNPT 1.8	706.2402.160.20	500	1/8	21.0	14.0	24.0	14.0	12	4.0	28
XWEV-08LNPT 1.4	706.2402.170.20	500	1/4	21.0	14.0	26.0	11.0	12	6.0	32
XWEV-08LNPT 3.8	706.2402.180.20	500	3/8	22.0	15.0	28.0	12.0	14	6.0	47
XWEV-08LNPT 1.2	706.2402.185.20	500	1/2	26.0	19.0	34.0	12.0	17	6.0	95
XWEV-10LNPT 1.4	706.2402.270.20	500	1/4	22.0	15.0	26.0	12.0	14	7.0	40
XWEV-10LNPT 3.8	706.2402.280.20	500	3/8	22.0	15.0	28.0	12.0	14	8.0	45
XWEV-10LNPT 1.2	706.2402.285.20	400	1/2	28.0	21.0	30.0	14.0	17	8.0	88
XWEV-12LNPT 1.4	706.2402.380.20	400	1/4	24.0	17.0	26.0	14.0	17	7.0	52
XWEV-12LNPT 3.8	706.2402.390.20	400	3/8	24.0	17.0	28.0	14.0	17	9.0	58
XWEV-12LNPT 1.2	706.2402.400.20	400	1/2	28.0	21.0	34.0	14.0	17	10.0	85
XWEV-15LNPT 1.2	706.2402.534.20	400	1/2	28.0	21.0	34.0	14.0	19	10.0	106
XWEV-18LNPT 1.2	706.2402.646.20	400	1/2	31.0	23.5	36.0	17.0	24	14.0	124
XWEV-18LNPT 3.4	706.2402.648.20	250	3/4	31.0	23.5	36.0	17.0	24	15.0	146
XWEV-22LNPT 3.4	706.2402.768.20	250	3/4	35.0	27.5	42.0	21.0	27	18.0	186
XWEV-28LNPT 1.1	706.2402.850.20	250	1	38.0	30.5	48.0	20.0	36	23.0	334
XWEV-35LNPT 5.4	706.2402.944.20	250	1 1/4	45.0	34.5	54.0	27.0	41	30.0	474
XWEV-42LNPT 3.2	706.2402.992.20	250	1 1/2	51.0	40.0	61.0	33.0	50	36.0	704

**Winkel-Einschraubverschraubungen NPT**  
**Male adaptor elbow fittings NPT**  
**Racores para roscar en codo NPT**

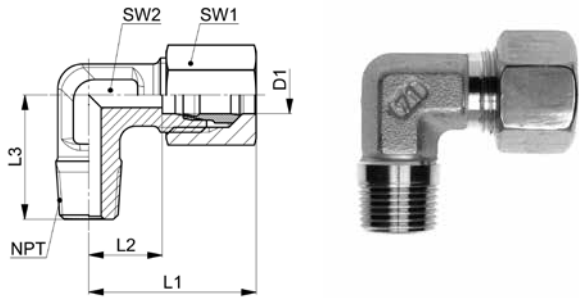

10

**WEV-..LNPT**

Type-D1 NPT	Mat.-Nr.	PN	NPT	L1	L2	L3	SW1	SW2	g/Stk
NPT=Einschraubgewinde NPT      NPT=tapered male adaptor thread NPT      NPT=rosca de conexión cónica NPT									
WEV-04LLNPT 1.8	708.2402.060.10	100	1/8	21.0	11.0	17.0	10	9	17
WEV-06LLNPT 1.8	708.2402.100.10	100	1/8	21.0	9.5	17.0	12	9	18
WEV-08LLNPT 1.8	708.2402.160.10	100	1/8	23.0	11.5	20.0	14	12	24
WEV-06LNPT 1.8	708.2402.100.20	500	1/8	27.0	12.0	20.0	14	12	32
WEV-06LNPT 1.4	708.2402.110.20	500	1/4	25.0	10.0	25.5	14	12	36
WEV-06LNPT 3.8	708.2402.120.20	500	3/8	29.0	14.0	28.0	14	14	52
WEV-08LNPT 1.8	708.2402.160.20	500	1/8	29.0	14.0	24.0	17	12	42
WEV-08LNPT 1.4	708.2402.170.20	500	1/4	29.0	14.0	26.0	17	12	44
WEV-08LNPT 3.8	708.2402.180.20	500	3/8	30.0	15.0	28.0	17	14	71
WEV-08LNPT 1.2	708.2402.185.20	500	1/2	34.0	19.0	34.0	17	17	104
WEV-10LNPT 1.4	708.2402.270.20	500	1/4	30.0	15.0	26.0	19	14	56
WEV-10LNPT 3.8	708.2402.280.20	500	3/8	30.0	15.0	28.0	19	14	60
WEV-10LNPT 1.2	708.2402.285.20	500	1/2	36.5	21.0	30.0	19	17	100
WEV-12LNPT 1.4	708.2402.380.20	400	1/4	32.0	17.0	26.0	22	17	76
WEV-12LNPT 3.8	708.2402.390.20	400	3/8	32.0	17.0	28.0	22	17	76
WEV-12LNPT 1.2	708.2402.400.20	400	1/2	36.5	21.0	34.0	22	17	118
WEV-15LNPT 1.2	708.2402.534.20	400	1/2	36.0	21.0	34.0	27	19	138
WEV-18LNPT 1.2	708.2402.646.20	400	1/2	40.0	23.5	36.0	32	24	184
WEV-18LNPT 3.4	708.2402.648.20	400	3/4	40.0	23.5	36.0	32	24	200
WEV-22LNPT 3.4	708.2402.768.20	250	3/4	44.5	27.5	42.0	36	27	252
WEV-28LNPT 1.1	708.2402.850.20	250	1	47.0	30.5	48.0	41	36	420
WEV-35LNPT 5.4	708.2402.944.20	250	1 1/4	56.0	34.5	54.0	50	41	587
WEV-42LNPT 3.2	708.2402.992.20	250	1 1/2	63.0	40.0	61.0	60	50	845

Baum Maße sind Ungefährmaße bei angezogener Überwurfmutter.

Sizes are approximate dimensions at tightened nut.

Las medidas son aproximadas con la tuerca de unión apretada.

**Winkel-Einschraubstutzen NPT**

**Male adaptor elbow connectors NPT**

**Cuerpos para roscar en codo NPT**

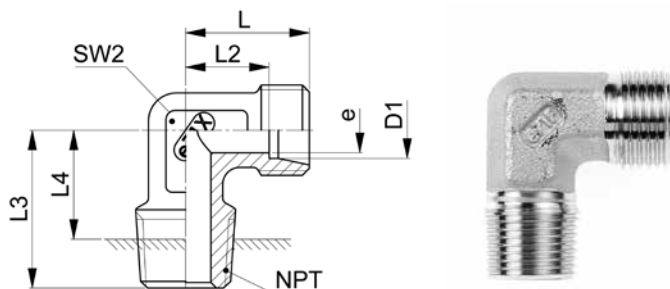

**XWEV-..SNPT**

Type-D1 NPT	Mat.-Nr.	PN	NPT	L	L2	L3	L4	SW2	e	g/Stk
NPT=Einschraubgewinde NPT		NPT=tapered male adaptor thread NPT			NPT=rosca de conexión cónica NPT					
XWEV-06SNPT 1.4	706.2402.110.30	800	1/4	23.0	16.0	26.0	15.0	12	4.0	40
XWEV-06SNPT 3.8	706.2402.120.30	800	3/8	23.0	16.0	28.0	15.0	14	4.0	56
XWEV-06SNPT 1.2	706.2402.125.30	800	1/2	23.0	16.0	33.0	13.0	17	4.0	93
XWEV-08SNPT 1.4	706.2402.170.30	800	1/4	24.0	17.0	26.0	16.0	14	5.0	52
XWEV-08SNPT 3.8	706.2402.180.30	800	3/8	25.0	18.0	28.0	17.0	17	5.0	71
XWEV-08SNPT 1.2	706.2402.185.30	800	1/2	28.0	21.0	34.0	18.0	17	6.0	103
XWEV-10SNPT 1.4	706.2402.270.30	800	1/4	25.0	17.5	26.0	17.0	17	7.0	61
XWEV-10SNPT 3.8	706.2402.280.30	800	3/8	25.0	17.5	28.0	17.0	17	7.0	72
XWEV-12SNPT 1.4	706.2402.380.30	630	1/4	29.0	21.5	27.0	21.0	17	7.0	75
XWEV-12SNPT 3.8	706.2402.390.30	630	3/8	29.0	21.5	28.0	21.0	17	8.0	83
XWEV-12SNPT 1.2	706.2402.400.30	630	1/2	29.0	21.5	33.0	19.0	17	8.0	104
XWEV-14SNPT 3.8	706.2402.502.30	630	3/8	30.0	22.0	28.0	22.0	19	8.0	99
XWEV-14SNPT 1.2	706.2402.504.30	630	1/2	30.0	22.0	34.0	20.0	19	10.0	117
XWEV-16SNPT 1.2	706.2402.655.30	630	1/2	33.0	24.5	36.0	13.0	24	12.0	149
XWEV-20SNPT 3.4	706.2402.708.30	420	3/4	37.0	26.5	42.0	25.0	27	16.0	223
XWEV-25SNPT 1.1	706.2402.810.30	420	1	42.0	30.0	48.0	28.0	36	20.0	403
XWEV-30SNPT 5.4	706.2402.902.30	420	1 1/4	49.0	35.5	54.0	35.0	41	25.0	645
XWEV-38SNPT 3.2	706.2402.953.30	420	1 1/2	57.0	41.0	61.0	43.0	50	32.0	941

**Winkel-Einschraubverschraubungen NPT**  
**Male adaptor elbow fittings NPT**  
**Racores para roscar en codo NPT**

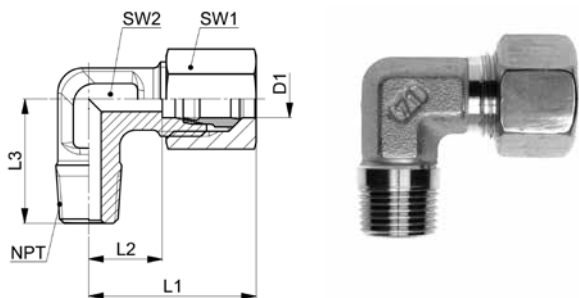

10

**WEV-..SNPT**

Type-D1 NPT	Mat.-Nr.	PN	NPT	L1	L2	L3	SW1	SW2	g/Stk
NPT=Einschraubgewinde NPT	NPT=tapered male adaptor thread NPT		NPT=rosca de conexión cónica NPT						
WEV-06SNPT 1.4	708.2402.110.30	800	1/4	31.0	16.3	26.0	17	12	54
WEV-06SNPT 3.8	708.2402.120.30	800	3/8	31.0	16.0	28.0	17	14	70
WEV-06SNPT 1.2	708.2402.125.30	800	1/2	31.0	16.0	33.0	17	17	99
WEV-08SNPT 1.4	708.2402.170.30	800	1/4	32.5	17.0	26.0	19	14	68
WEV-08SNPT 3.8	708.2402.180.30	800	3/8	33.0	18.0	28.0	19	17	76
WEV-08SNPT 1.2	708.2402.185.30	800	1/2	36.0	21.0	34.0	19	17	133
WEV-10SNPT 1.4	708.2402.270.30	800	1/4	34.5	17.5	26.0	22	17	88
WEV-10SNPT 3.8	708.2402.280.30	800	3/8	34.5	17.5	28.0	22	17	98
WEV-12SNPT 1.4	708.2402.380.30	630	1/4	38.0	21.5	27.0	24	17	104
WEV-12SNPT 3.8	708.2402.390.30	630	3/8	38.0	21.5	28.0	24	17	112
WEV-12SNPT 1.2	708.2402.400.30	630	1/2	39.0	21.5	33.0	24	17	132
WEV-14SNPT 3.8	708.2402.502.30	630	3/8	40.5	22.0	28.0	27	19	148
WEV-14SNPT 1.2	708.2402.504.30	630	1/2	40.0	22.0	34.0	27	19	158
WEV-16SNPT 1.2	708.2402.655.30	630	1/2	43.0	24.5	36.0	30	24	206
WEV-20SNPT 3.4	708.2402.708.30	420	3/4	49.5	26.5	42.0	36	27	318
WEV-25SNPT 1.1	708.2402.810.30	420	1	55.5	30.0	48.0	46	36	616
WEV-30SNPT 5.4	708.2402.902.30	420	1 1/4	63.5	35.5	54.0	50	41	829
WEV-38SNPT 3.2	708.2402.953.30	420	1 1/2	74.0	41.0	61.0	60	50	1175

Baumaße sind Ungefähрмаße bei angezogener Überwurfmutter.

Sizes are approximate dimensions at tightened nut.

Las medidas son aproximadas con la tuerca de unión apretada.

**T-Einschraubstutzen**

Abdichtung durch Dichtkante Form B nach DIN 3852-2

**Male adaptor T connectors**

sealing edge form B acc. DIN 3852-2

**Cuerpos para roscar T**

cierre hermético mediante borde de obturación forma B según DIN 3852-2

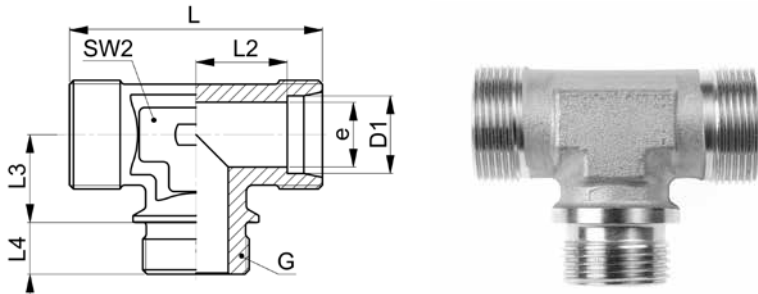

**XTEV-..LR/SR**

Type-D1 G	Mat.-Nr.	PN	G	L	L2	L3	L4	SW2	e	g/Stk
G=Rohrgewinde (zylindrisch)		G=BSP thread (parallel)				G=rosca de conexión (cilíndrica)				
● XTEV-22LR 3.4	706.3702.768.20	250	3/4	70.0	27.5	26.0	16.0	27	18.0	233
● XTEV-28LR 1.1	706.3702.850.20	250	1	76.0	30.5	30.0	18.0	36	23.0	400
● XTEV-42LR 3.2	706.3702.992.20	250	1 1/2	102.0	40.0	39.0	22.0	50	36.0	872
● XTEV-20SR 3.4	706.3702.704.30	420	3/4	74.0	26.5	26.0	16.0	27	16.0	298
● XTEV-25SR 1.1	706.3702.810.30	420	1	84.0	30.0	30.0	18.0	36	20.0	538
● XTEV-38SR 3.2	706.3702.953.30	420	1 1/2	114.0	41.0	39.0	22.0	50	32.0	1218

**T-Einschraubverschraubungen**

Abdichtung durch Dichtkante Form B nach DIN 3852-2

**Male adaptor T fittings**

sealing edge form B acc. DIN 3852-2

**Racores para roscar T**

cierre hermético mediante borde de obturación forma B según DIN 3852-2

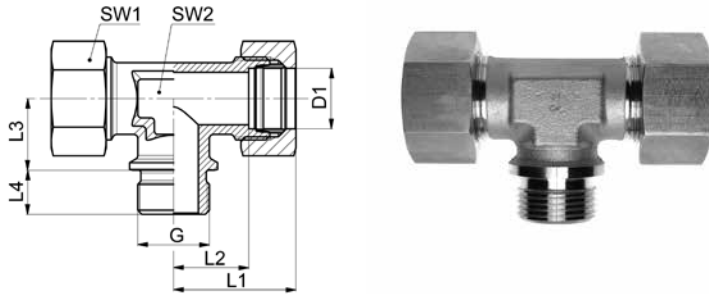

10

**TEV-..LR/SR**

Type-D1 G	Mat.-Nr.	PN	G	L1	L2	L3	L4	SW1	SW2	g/Stk
G=Rohrgewinde (zylindrisch)		G=BSP thread (parallel)				G=rosca de conexión (cilíndrica)				
● TEV-22LR 3.4	708.3702.768.20	250	3/4	44.5	27.5	26.0	16.0	36	27	381
● TEV-28LR 1.1	708.3702.850.20	250	1	47.5	30.5	30.0	18.0	41	36	544
● TEV-42LR 3.2	708.3702.992.20	250	1 1/2	63.5	40.0	39.0	22.0	60	50	1408
● TEV-20SR 3.4	708.3702.704.30	420	3/4	49.5	26.5	26.0	16.0	36	27	499
● TEV-25SR 1.1	708.3702.810.30	420	1	55.5	30.0	30.0	18.0	46	36	921
● TEV-38SR 3.2	708.3702.953.30	420	1 1/2	74.0	41.0	39.0	22.0	60	50	1722

Baumaße sind Ungefährmaße bei angezogener Überwurfmutter.

Sizes are approximate dimensions at tightened nut.

Las medidas son aproximadas con la tuerca de unión apretada.

**T-Einschraubstutzen**

Abdichtung im Kegengewinde Form C nach DIN 3852-2

**Male adaptor T connectors**

taper thread sealing form C acc. DIN 3852-2

**Cuerpos para roscar T**

cierre hermético con rosca cónica forma C según DIN 3852-2

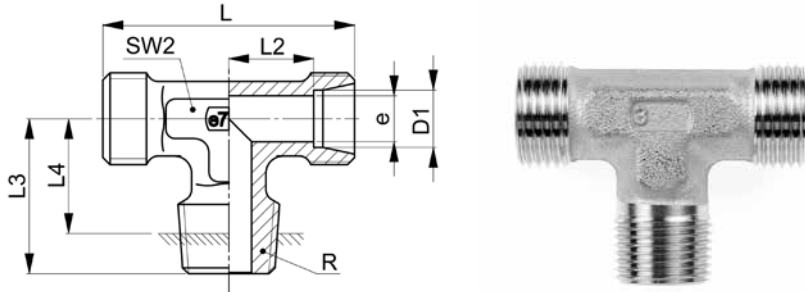

**XTEV-..LRK/SRK**

Type-D1 R	Mat.-Nr.	PN	R	L	L2	L3	L4	SW2	e	g/Stk
R=Rohrgewinde (kegelig)		R=BSP thread (tapered)				R=rosca para tubos (cónica)				
● XTEV-06LRK 1.8	706.3701.100.20	250	1/8	38.0	12.0	20.0	15.0	12	4.0	32
XTEV-06LRK 1.4	706.3701.110.20	250	1/4	38.0	12.0	20.0	12.0	12	4.0	43
● XTEV-08LRK 1.4	706.3701.170.20	250	1/4	42.0	14.0	26.0	18.0	12	6.0	44
● XTEV-10LRK 1.4	706.3701.270.20	250	1/4	44.0	15.0	27.0	19.0	14	8.0	52
XTEV-10LRK 3.8	706.3701.280.20	250	3/8	44.0	15.0	27.0	19.0	14	8.0	60
● XTEV-12LRK 3.8	706.3701.390.20	250	3/8	48.0	17.0	28.0	20.0	17	10.0	71
XTEV-12LRK 1.2	706.3701.400.20	250	1/2	56.0	21.0	28.0	18.0	17	10.0	107
● XTEV-15LRK 1.2	706.3701.534.20	250	1/2	56.0	21.0	34.0	24.0	19	12.0	132
● XTEV-18LRK 1.2	706.3701.646.20	160	1/2	62.0	23.5	36.0	26.0	24	15.0	194
● XTEV-06SRK 1.4	706.3701.110.30	400	1/4	46.0	16.0	26.0	18.0	12	4.0	58
● XTEV-08SRK 1.4	706.3701.170.30	400	1/4	48.0	17.0	27.0	19.0	14	5.0	72
● XTEV-10SRK 3.8	706.3701.280.30	400	3/8	50.0	17.5	28.0	20.0	17	7.0	94
● XTEV-12SRK 3.8	706.3701.390.30	400	3/8	58.0	21.5	28.0	20.0	17	8.0	118
XTEV-14SRK 1.2	706.3701.504.30	400	1/2	60.0	22.0	32.0	22.0	19	10.0	153
● XTEV-16SRK 1.2	706.3701.566.30	400	1/2	66.0	24.5	32.0	22.0	24	12.0	193

Druckangaben gelten in Verbindung mit zylindrischem Innengewinde.

Pressure information applies in connection with parallel female thread.

Datos de presión válidos en combinación con roscas interiores cilíndricas.

Einbaumaß L4 ist abhängig von den Masstoleranzen des Gegenstückes.

Installation size L4 is dependent on the size tolerances of the counterpart.

Distancia de referencia L4 según las tolerancias dimensionales de la contrapieza.

## T-Einschraubverschraubungen

Abdichtung im Kegelgewinde Form C nach DIN 3852-2

## Male adaptor T fittings

taper thread sealing form C acc. DIN 3852-2

## Racores para roscar T

cierre hermético con rosca cónica forma C según DIN 3852-2

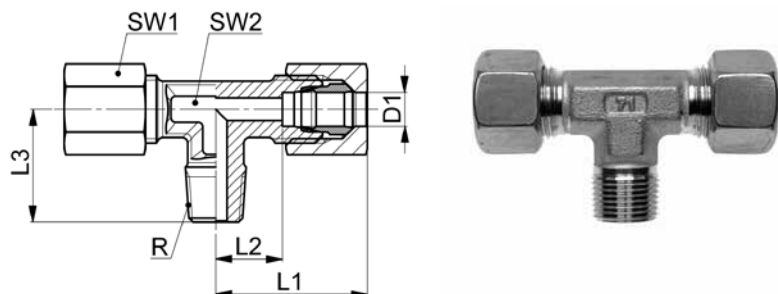

10

### TEV-..LRK/SRK

Type-D1 R	Mat.-Nr.	PN	R	L1	L2	L3	SW1	SW2	g/Stk
R=Rohrgewinde (kegelig)		R=BSP thread (tapered)				R=rosca para tubos (cónica)			
● TEV-06LRK 1.8	708.3701.100.20	250	1/8	27.0	12.0	20.0	14	12	52
TEV-06LRK 1.4	708.3701.110.20	250	1/4	27.0	12.0	20.0	14	12	56
● TEV-08LRK 1.4	708.3701.170.20	250	1/4	29.0	14.0	26.0	17	12	72
● TEV-10LRK 1.4	708.3701.270.20	250	1/4	30.5	15.0	27.0	19	14	76
TEV-10LRK 3.8	708.3701.280.20	250	3/8	30.5	15.0	27.0	19	14	82
● TEV-12LRK 3.8	708.3701.390.20	250	3/8	32.5	17.0	28.0	22	17	102
TEV-12LRK 1.2	708.3701.400.20	250	1/2	37.0	21.0	28.0	22	17	138
● TEV-15LRK 1.2	708.3701.534.20	250	1/2	37.0	21.0	34.0	27	19	201
● TEV-18LRK 1.2	708.3701.646.20	160	1/2	40.5	23.5	36.0	32	24	296
● TEV-06SRK 1.4	708.3701.110.30	400	1/4	31.0	16.0	26.0	17	12	100
● TEV-08SRK 1.4	708.3701.170.30	400	1/4	32.0	17.0	27.0	19	14	113
● TEV-10SRK 3.8	708.3701.280.30	400	3/8	34.5	17.5	28.0	22	17	135
● TEV-12SRK 3.8	708.3701.390.30	400	3/8	38.5	21.5	28.0	24	17	159
TEV-14SRK 1.2	708.3701.504.30	400	1/2	40.5	22.0	32.0	27	19	238
● TEV-16SRK 1.2	708.3701.566.30	400	1/2	44.0	24.5	32.0	30	24	339

Druckangaben gelten in Verbindung mit zylindrischem Innengewinde.

Pressure information applies in connection with parallel female thread.

Datos de presión válidos en combinación con roscas interiores cilíndricas.

Baumaße sind Ungefährmaße bei angezogener Überwurfmutter.

Sizes are approximate dimensions at tightened nut.

Las medidas son aproximadas con la tuerca de unión apretada.

**T-Einschraubstutzen NPT**

**Male adaptor T connectors NPT**

**Cuerpos para roscar T NPT**

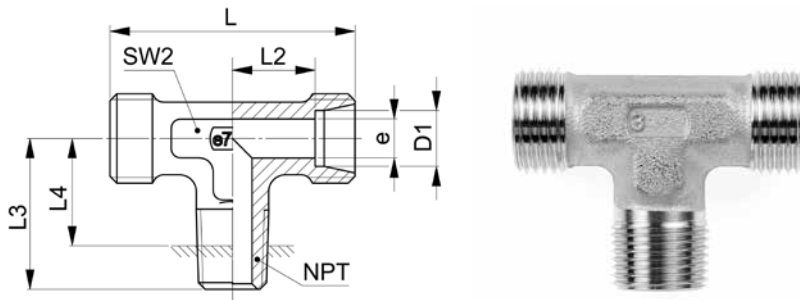

**XTEV-..LNPT/SNPT**

Type -D1 NPT	Mat.-Nr.	PN	NPT	L	L2	L3	L4	SW2	e	g/Stk
NPT=Einschraubgewinde NPT		NPT=tapered male adaptor thread NPT			NPT=rosca de conexión cónica NPT					
XTEV-06LNPT 1.8	706.3704.100.20	500	1/8	38.0	12.0	20.0	13.5	12	4.0	32
XTEV-10LNPT 1.4	706.3704.270.20	500	1/4	44.0	15.0	27.0	17.0	14	7.0	52
XTEV-12LNPT 3.8	706.3704.390.20	400	3/8	48.0	17.0	28.0	18.0	17	9.0	69
XTEV-15LNPT 1.2	706.3704.534.20	400	1/2	56.0	21.0	34.0	20.0	19	12.0	121
XTEV-18LNPT 1.2	706.3704.646.20	400	1/2	62.0	23.5	36.0	22.0	24	14.0	151
XTEV-22LNPT 3.4	706.3704.768.20	250	3/4	70.0	27.5	42.0	28.0	27	18.0	235
XTEV-06SNPT 1.4	706.3704.110.30	800	1/4	46.0	16.0	26.0	16.0	12	4.0	55
XTEV-12SNPT 3.8	706.3704.390.30	630	3/8	58.0	21.5	28.0	18.0	17	8.0	115
XTEV-16SNPT 1.2	706.3704.566.30	630	1/2	66.0	24.5	36.0	22.0	24	12.0	187

**T-Einschraubverschraubungen NPT**  
**Male adaptor T fittings NPT**  
**Racores para roscar T NPT**

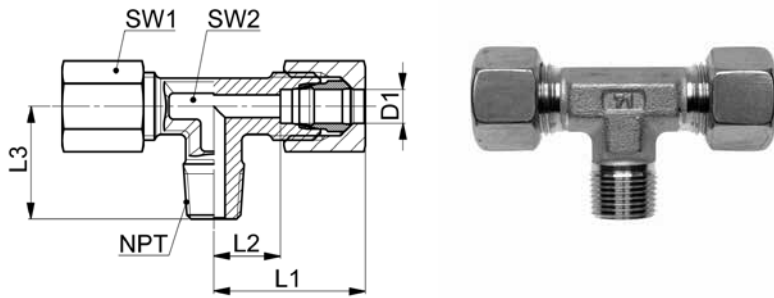

10

**TEV-..LNPT/SNPT**

Type-D1 NPT	Mat.-Nr.	PN	NPT	L1	L2	L3	SW1	SW2	g/Stk
NPT=Einschraubgewinde NPT	NPT=tapered male adaptor thread NPT		NPT=rosca de conexión cónica NPT						
TEV-06LNPT 1.8	708.3704.100.20	500	1/8	27.0	12.0	20.0	14	12	50
TEV-10LNPT 1.4	708.3704.270.20	500	1/4	30.5	15.0	27.0	19	14	90
TEV-12LNPT 3.8	708.3704.390.20	400	3/8	32.5	17.0	28.0	22	17	129
TEV-15LNPT 1.2	708.3704.534.20	400	1/2	37.0	21.0	34.0	27	19	215
TEV-18LNPT 1.2	708.3704.646.20	400	1/2	40.5	23.5	36.0	32	24	295
TEV-22LNPT 3.4	708.3704.768.20	250	3/4	44.5	27.5	42.0	36	27	433
TEV-06SNPT 1.4	708.3704.110.30	800	1/4	31.0	16.0	26.0	17	12	94
TEV-12SNPT 3.8	708.3704.390.30	630	3/8	38.5	21.5	28.0	24	17	184
TEV-16SNPT 1.2	708.3704.566.30	630	1/2	44.0	24.5	36.0	30	24	327

Baumaße sind Ungefährmaße bei angezogener Überwurfmutter.

Sizes are approximate dimensions at tightened nut.

Las medidas son aproximadas con la tuerca de unión apretada.

**L-Einschraubstutzen**

Abdichtung durch Dichtkante Form B nach DIN 3852-2

**Male adaptor L connectors**

sealing edge form B acc. DIN 3852-2

**Cuerpos para roscar L**

cierre hermético mediante borde de obturación forma B según DIN 3852-2

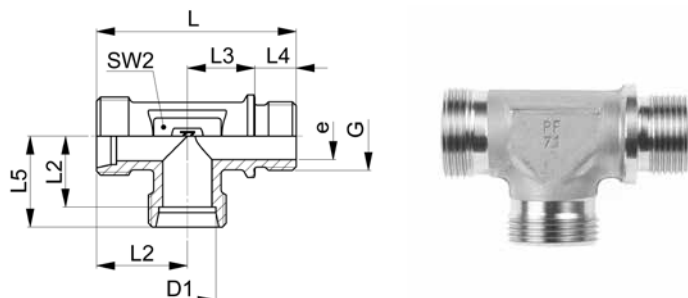

**XLEV-..LR**

Type-D1 G	Mat.-Nr.	PN	G	L	L2	L3	L4	L5	SW2	e	g/Stk
G=Rohrgewinde (zylindrisch)		G=BSP thread (parallel)									
											G=rosca de conexión (cilíndrica)
● XLEV-22LR 3.4	706.3712.708.20	250	3/4	77.0	27.5	26.0	16.0	35.0	27	18.0	235
● XLEV-28LR 1.1	706.3712.850.20	250	1	86.0	30.5	30.0	18.0	38.0	36	23.0	405
● XLEV-42LR 3.2	706.3712.992.20	250	1 1/2	112.0	40.0	39.0	22.0	51.0	50	36.0	877

**L-Einschraubverschraubungen**

Abdichtung durch Dichtkante Form B nach DIN 3852-2

**Male adaptor L fittings**

sealing edge form B acc. DIN 3852-2

**Racores para roscar L**

cierre hermético mediante borde de obturación forma B según DIN 3852-2

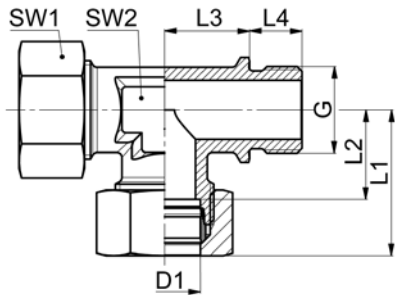

10

**LEV-..LR**

Type-D1 G	Mat.-Nr.	PN	G	L1	L2	L3	L4	SW1	SW2	g/Stk
G=Rohrgewinde (zylindrisch)		G=BSP thread (parallel)				G=rosca de conexión (cilíndrica)				
● LEV-22LR 3.4	708.3712.708.20	250	3/4	44.0	27.5	26.0	16.0	36	27	371
● LEV-28LR 1.1	708.3712.850.20	250	1	47.0	30.5	30.0	18.0	41	36	544
● LEV-42LR 3.2	708.3712.992.20	250	1 1/2	63.0	40.0	39.0	22.0	60	50	1240

Baumaße sind Ungefährmaße bei angezogener Überwurfmutter.

Sizes are approximate dimensions at tightened nut.

Las medidas son aproximadas con la tuerca de unión apretada.

**L-Einschraubstutzen**

Abdichtung im Kegengewinde Form C nach DIN 3852-2

**Male adaptor L connectors**

taper thread sealing form C acc. DIN 3852-2

**Cuerpos para roscar L**

cierre hermético con rosca cónica forma C según DIN 3852-2

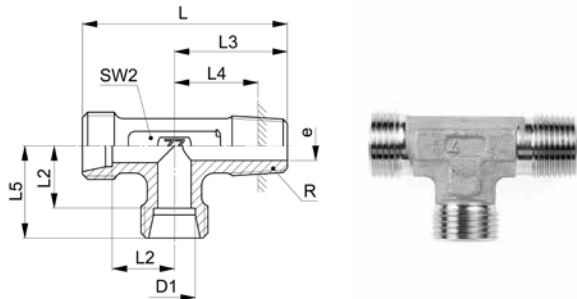

**XLEV-..LRK/SRK**

Type-D1 R	Mat.-Nr.	PN	R	L	L2	L3	L4	L5	SW2	e	g/Stk
R=Rohrgewinde (kegelig)		R=BSP thread (tapered)									
											R=rosca para tubos (cónica)
● XLEV-06LRK 1.8	706.3711.100.20	250	1/8	39.0	12.0	20.0	15.0	19.0	12	4.0	32
● XLEV-08LRK 1.4	706.3711.170.20	250	1/4	47.0	14.0	26.0	18.0	21.0	12	6.0	44
● XLEV-10LRK 1.4	706.3711.270.20	250	1/4	49.0	15.0	27.0	19.0	22.0	14	7.0	52
● XLEV-12LRK 3.8	706.3711.390.20	250	3/8	52.0	17.0	28.0	20.0	24.0	17	9.0	72
● XLEV-15LRK 1.2	706.3711.534.20	250	1/2	62.0	21.0	34.0	24.0	28.0	19	11.0	134
● XLEV-18LRK 1.2	706.3711.646.20	160	1/2	67.0	23.5	36.0	26.0	31.0	24	14.0	173
● XLEV-06SRK 1.4	706.3711.111.30	400	1/4	49.0	16.0	26.0	18.0	23.0	12	4.0	58
● XLEV-08SRK 1.4	706.3711.170.30	400	1/4	51.0	17.0	27.0	19.0	24.0	14	5.0	73
● XLEV-10SRK 3.8	706.3711.280.30	400	3/8	53.0	17.5	28.0	20.0	25.0	17	7.0	91
● XLEV-12SRK 3.8	706.3711.390.30	400	3/8	57.0	21.5	28.0	20.0	29.0	17	8.0	119
● XLEV-14SRK 1.2	706.3711.504.30	400	1/2	62.0	22.0	32.0	22.0	30.0	19	10.0	155
● XLEV-16SRK 1.2	706.3711.566.30	400	1/2	65.0	24.5	32.0	22.0	33.0	24	12.0	195

Druckangaben gelten in Verbindung mit zylindrischem Innengewinde.

Pressure information applies in connection with parallel female thread.

Datos de presión válidos en combinación con roscas interiores cilíndricas.

Einbaumaß L4 ist abhängig von den Masstoleranzen des Gegenstückes.

Installation size L4 is dependent on the size tolerances of the counterpart.

Distancia de referencia L4 según las tolerancias dimensionales de la contrapieza.

### L-Einschraubverschraubungen

Abdichtung im Kegengewinde Form C nach DIN 3852-2

### Male adaptor L fittings

taper thread sealing form C acc. DIN 3852-2

### Racores para roscar L

cierre hermético con rosca cónica forma C según DIN 3852-2

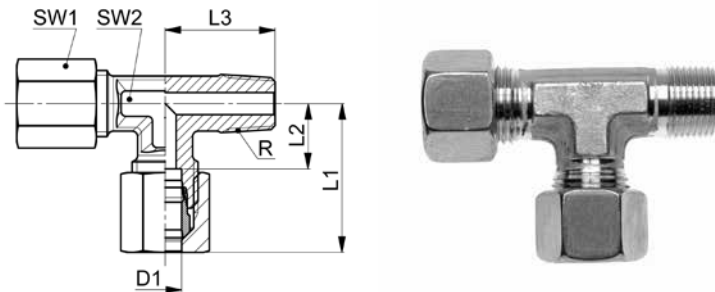

10

## LEV-..LRK/SRK

Type-D1 R	Mat.-Nr.	PN	R	L1	L2	L3	SW1	SW2	g/Stk
R=Rohrgewinde (kegelig)		R=BSP thread (tapered)				R=rosca para tubos (cónica)			
● LEV-06LRK 1.8	708.3711.100.20	250	1/8	27.0	12.0	20.0	14	12	53
● LEV-08LRK 1.4	708.3711.170.20	250	1/4	29.0	14.0	26.0	17	12	73
● LEV-10LRK 1.4	708.3711.270.20	250	1/4	30.0	15.0	27.0	19	14	100
● LEV-12LRK 3.8	708.3711.390.20	250	3/8	32.0	17.0	28.0	22	17	120
● LEV-15LRK 1.2	708.3711.534.20	250	1/2	36.0	21.0	34.0	27	19	167
● LEV-18LRK 1.2	708.3711.646.20	160	1/2	40.0	23.5	36.0	32	24	296
● LEV-06SRK 1.4	708.3711.111.30	400	1/4	31.0	16.0	26.0	17	12	97
● LEV-08SRK 1.4	708.3711.170.30	400	1/4	32.0	17.0	27.0	19	14	128
● LEV-10SRK 3.8	708.3711.280.30	400	3/8	34.0	17.5	28.0	22	17	172
● LEV-12SRK 3.8	708.3711.390.30	400	3/8	38.0	21.5	28.0	24	17	244
● LEV-14SRK 1.2	708.3711.504.30	400	1/2	41.0	22.0	32.0	27	19	245
● LEV-16SRK 1.2	708.3711.566.30	400	1/2	43.0	24.5	32.0	30	24	320

Druckangaben gelten in Verbindung mit zylindrischem Innengewinde.

Pressure information applies in connection with parallel female thread.

Datos de presión válidos en combinación con roscas interiores cilíndricas.

Baumäße sind Ungefährmaße bei angezogener Überwurfmutter.

Sizes are approximate dimensions at tightened nut.

Las medidas son aproximadas con la tuerca de unión apretada.

**L-Einschraubstutzen NPT**

**Male adaptor L connectors NPT**

**Cuerpos para roscar L NPT**

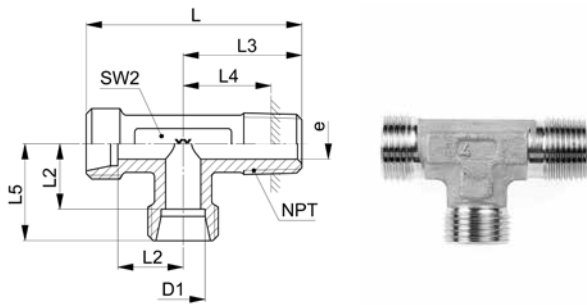

**XLEV-..LNPT/SNPT**

Type -D1 NPT	Mat.-Nr.	PN	NPT	L	L2	L3	L4	L5	SW2	e	g/Stk
NPT=Einschraubgewinde NPT		NPT=tapered male adaptor thread NPT			NPT=rosca de conexión cónica NPT						
XLEV-08LNPT 1.4	706.3755.170.20	500	1/4	47.0	14.0	26.0	16.0	21.0	12	6.0	44
XLEV-15LNPT 1.2	706.3755.534.20	400	1/2	62.0	21.0	34.0	20.0	28.0	19	12.0	126
XLEV-22LNPT 3.4	706.3755.768.20	250	3/4	77.0	27.5	42.0	28.0	35.0	27	18.0	246
XLEV-06SNPT 1.4	706.3755.110.30	800	1/4	49.0	16.0	26.0	16.0	23.0	12	4.0	58
XLEV-08SNPT 1.4	706.3755.170.30	800	1/4	51.0	17.0	27.0	17.0	24.0	14	5.0	73
XLEV-16SNPT 1.2	706.3755.566.30	630	1/2	65.0	24.5	32.0	18.0	33.0	24	12.0	188

**L-Einschraubverschraubungen NPT**  
**Male adaptor L fittings NPT**  
**Racores para roscar L NPT**

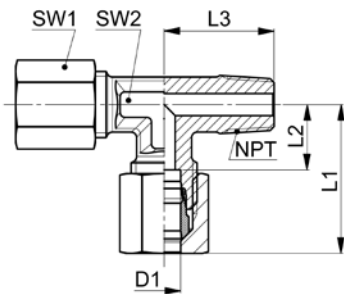

10

**LEV-..LNPT/SNPT**

Type -D1 NPT	Mat.-Nr.	PN	NPT	L1	L2	L3	SW1	SW2	g/Stk
NPT=Einschraubgewinde NPT		NPT=tapered male adaptor thread NPT			NPT=rosca de conexión cónica NPT				
LEV-08LNPT 1.4	708.3755.170.20	500	1/4	29.0	14.0	26.0	17	12	77
LEV-15LNPT 1.2	708.3755.534.20	400	1/2	36.0	21.0	34.0	27	19	191
LEV-22LNPT 3.4	708.3755.768.20	250	3/4	44.0	27.5	42.0	36	27	347
LEV-06SNPT 1.4	708.3755.110.30	800	1/4	31.0	16.0	26.0	17	12	103
LEV-08SNPT 1.4	708.3755.170.30	800	1/4	32.0	17.0	27.0	19	14	133
LEV-16SNPT 1.2	708.3755.566.30	630	1/2	43.0	24.5	32.0	30	24	320

Baumaße sind Ungefährmaße bei angezogener Überwurfmutter.

Sizes are approximate dimensions at tightened nut.

Las medidas son aproximadas con la tuerca de unión apretada.

**Gerade Thermoelementstutzen**

Abdichtung durch Dichtkante Form B nach DIN 3852-2

**Straight connectors for temperature sensors**

sealing edge form B acc. DIN 3852-2

**Cuerpos para roscar rectos de termosonda**

cierre hermético mediante borde de obturación forma B según DIN 3852-2

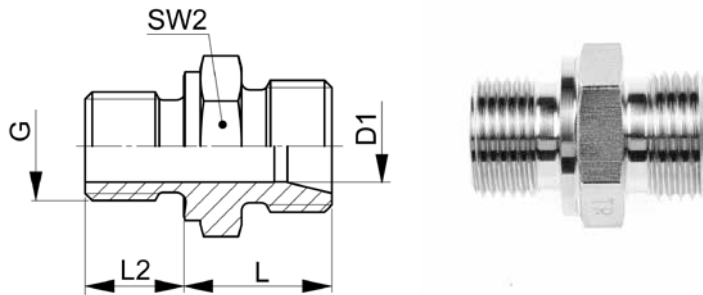

**XGEV-..LR D**

Type-D1 G	Mat.-Nr.	PN	G	L	L2	SW2	g/Stk
G=Rohrgewinde (zylindrisch)	G=BSP thread (parallel)				G=rosca de conexión (cilíndrica)		
XGEV-06LR 1.4 D	706.1151.110.20	500	1/4	17.0	12.0	19	27
XGEV-08LR 3.8 D	706.1151.180.20	500	3/8	19.5	12.0	22	46
XGEV-10LR 1.2 D	706.1151.285.20	500	1/2	21.0	14.0	27	74
XGEV-12LR 1.2 D	706.1151.400.20	400	1/2	20.0	14.0	27	64
XGEV-12LR 3.4 D	706.1151.405.20	400	3/4	21.0	16.0	32	115

**Gerade Thermoelementverschraubungen**

Schneidringanschluss, Abdichtung durch Dichtkante Form B nach DIN 3852-2

**Straight fittings for temperature sensors**

cutting ring connection, sealing edge form B acc. DIN 3852-2

**Racores de termosonda**

conexión de anillo cortante, cierre hermético mediante borde de obturación forma B según DIN 3852-2

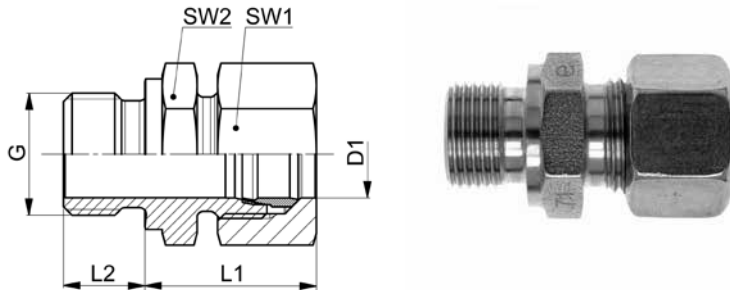

10

**GEV-..LR D**

Type-D1 G	Mat.-Nr.	PN	G	L1	L2	SW1	SW2	g/Stk
G=Rohrgewinde (zylindrisch)		G=BSP thread (parallel)			G=rosca de conexión (cilíndrica)			
GEV-06LR 1.4 D	708.1151.110.20	500	1/4	25.0	12.0	14	19	37
GEV-08LR 3.8 D	708.1151.180.20	500	3/8	27.5	12.0	17	22	58
GEV-10LR 1.2 D	708.1151.285.20	500	1/2	29.0	14.0	19	27	90
GEV-12LR 1.2 D	708.1151.400.20	400	1/2	28.0	14.0	22	27	87
GEV-12LR 3.4 D	708.1151.405.20	400	3/4	29.0	16.0	22	32	138

Baumaße sind Ungefährmaße bei angezogener Überwurfmutter.

Sizes are approximate dimensions at tightened nut.

Las medidas son aproximadas con la tuerca de unión apretada.

Auf Anfrage auch mit PTFE Klemmring möglich.

Available also with PTFE clamping ring on request.

También disponible, bajo demanda, con anillo de apriete de PTFE.

**PTFE-Klemmringe für Thermoelementverschraubungen**

**PTFE sealing rings for straight fittings for temperature sensors**

**Anillos de apriete de PTFE para racores de termosonda**

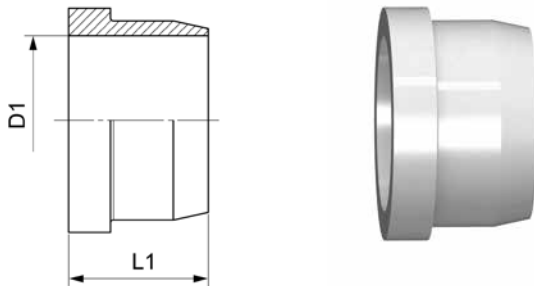

**PTFE-KLEMMRING**

Type -D1	Mat.-Nr.	PN	L1	g/Stk
PTFE-R-06 L/S	706.0016.060.13	10	9.0	1
PTFE-R-08 L/S	706.0016.080.13	10	9.0	1
PTFE-R-10 L/S	706.0016.100.13	10	10.0	1
PTFE-R-12 L/S	706.0016.120.13	10	10.0	1

## Gerade Einschraubstutzen mit Dichtkegel und O-Ring

Abdichtung durch Profildichtring Form E nach ISO 1179-2

## Straight male adaptor unions with taper and O-ring

profile sealing ring form E acc. ISO 1179-2

## Racores para roscar rectos con junta cónica y junta tórica

cierre hermético mediante junta con perfil forma E según ISO 1179-2

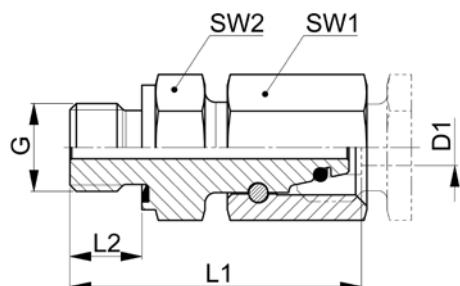

10

### EGKO-..LR WD/SR WD

Type-D1 G	Mat.-Nr.	PN	G	L1	L2	SW1	SW2	g/Stk
G=Rohrgewinde (zylindrisch)		G=BSP thread (parallel)			G=rosca de conexión (cilíndrica)			
EGKO-06LR 1.8 WD	708.1670.100.21	315	1/8	32.5	8.0	14	14	36
EGKO-08LR 1.4 WD	708.1670.170.21	315	1/4	41.5	12.0	17	19	57
EGKO-10LR 1.4 WD	708.1670.270.21	315	1/4	39.5	12.0	19	19	58
EGKO-10LR 3.8 WD	708.1670.280.21	315	3/8	41.0	12.0	19	22	78
EGKO-12LR 1.4 WD	708.1670.380.21	315	1/4	39.5	12.0	22	19	68
EGKO-12LR 3.8 WD	708.1670.390.21	315	3/8	46.0	12.0	22	22	95
EGKO-12LR 1.2 WD	708.1670.400.21	315	1/2	43.5	14.0	22	27	110
EGKO-15LR 1.2 WD	708.1670.534.21	315	1/2	46.0	14.0	27	27	144
EGKO-18LR 1.2 WD	708.1670.646.21	315	1/2	45.5	14.0	32	27	152
EGKO-22LR 1.2 WD	708.1670.764.21	160	1/2	48.5	14.0	36	27	206
EGKO-22LR 3.4 WD	708.1670.768.21	160	3/4	48.5	16.0	36	32	202
EGKO-28LR 1.1 WD	708.1670.850.21	160	1	53.0	18.0	46	41	356
EGKO-35LR 5.4 WD	708.1670.944.21	160	1 1/4	62.5	20.0	50	50	507
EGKO-42LR 3.2 WD	708.1670.992.21	160	1 1/2	68.5	22.0	60	55	664
EGKO-06SR 1.4 WD	708.1670.110.31	630	1/4	39.0	12.0	17	19	56
EGKO-08SR 1.4 WD	708.1670.170.31	630	1/4	41.5	12.0	19	19	62
EGKO-10SR 1.4 WD	708.1670.270.31	630	1/4	38.0	12.0	22	19	68
EGKO-10SR 3.8 WD	708.1670.280.31	630	3/8	44.0	12.0	22	22	92
EGKO-12SR 3.8 WD	708.1670.390.31	630	3/8	46.0	12.0	24	22	110
EGKO-12SR 1.2 WD	708.1670.400.31	630	1/2	49.0	14.0	24	27	153
EGKO-14SR 1.2 WD	708.1670.504.31	630	1/2	50.5	14.0	27	27	170
EGKO-16SR 1.2 WD	708.1670.566.31	400	1/2	51.0	14.0	30	27	230
EGKO-20SR 1.2 WD	708.1670.706.31	400	1/2	49.0	14.0	36	27	242
EGKO-20SR 3.4 WD	708.1670.704.31	400	3/4	59.0	16.0	36	32	286
EGKO-25SR 1.1 WD	708.1670.810.31	400	1	66.0	18.0	46	41	494
EGKO-30SR 5.4 WD	708.1670.902.31	400	1 1/4	70.5	20.0	50	50	674
EGKO-38SR 3.2 WD	708.1670.953.31	315	1 1/2	81.5	22.0	60	55	931

Baumaße sind Ungefährmaße bei angezogener Überwurfmutter.

Sizes are approximate dimensions at tightened nut.

Las medidas son aproximadas con la tuerca de unión apretada.

Dichtungsmaterial: FKM

Sealing material: FKM

Material de junta tórica: FKM.

ISO 8434-1-SWOSDS

## Gerade Einschraubstutzen mit Dichtkegel und O-Ring

Abdichtung durch Profildichtring Form E nach ISO 1179-2

## Straight male adaptor unions with taper and O-ring

profile sealing ring form E acc. ISO 1179-2

## Racores para roscar rectos con junta cónica y junta tórica

cierre hermético mediante junta con perfil forma E según ISO 1179-2

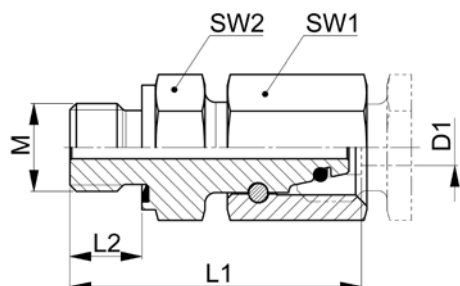

### EGKO-..LM WD/SM WD

Type-D1 M	Mat.-Nr.	PN	M	L1	L2	SW1	SW2	g/Stk
M=metrisches Gewinde (zylindrisch)	M=metric thread (parallel)	M=rosca métrica (cilíndrica)						
EGKO-06LM 10x1,0 WD	708.1671.180.21	315	10x1.0	32.5	8.0	14	14	36
EGKO-08LM 12x1,5 WD	708.1671.240.21	315	12x1.5	38.5	12.0	17	17	57
EGKO-10LM 14x1,5 WD	708.1671.280.21	315	14x1.5	39.5	12.0	19	19	58
EGKO-12LM 16x1,5 WD	708.1671.330.21	315	16x1.5	42.5	12.0	22	22	75
EGKO-15LM 18x1,5 WD	708.1671.390.21	315	18x1.5	43.5	12.0	27	24	144
EGKO-18LM 22x1,5 WD	708.1671.460.21	315	22x1.5	45.5	14.0	32	27	152
EGKO-22LM 26x1,5 WD	708.1671.535.21	160	26x1.5	48.5	16.0	36	32	202
EGKO-28LM 33x2,0 WD	708.1671.570.21	160	33x2.0	53.0	18.0	46	41	356
EGKO-35LM 42x2,0 WD	708.1671.600.21	160	42x2.0	62.5	20.0	50	50	507
EGKO-42LM 48x2,0 WD	708.1671.992.21	160	48x2.0	68.5	22.0	60	55	664
EGKO-06SM 12x1,5 WD	708.1671.195.31	630	12x1.5	39.0	12.0	17	17	56
EGKO-08SM 14x1,5 WD	708.1671.245.31	630	14x1.5	41.5	12.0	19	19	62
EGKO-10SM 16x1,5 WD	708.1671.285.31	630	16x1.5	44.0	12.0	22	22	92
EGKO-12SM 18x1,5 WD	708.1671.333.31	630	18x1.5	46.0	12.0	24	24	110
EGKO-14SM 20x1,5 WD	708.1671.382.31	630	20x1.5	50.5	14.0	27	27	170
EGKO-16SM 22x1,5 WD	708.1671.410.31	400	22x1.5	51.0	14.0	30	27	230
EGKO-20SM 27x2,0 WD	708.1671.506.31	400	27x2.0	59.0	16.0	36	32	286
EGKO-25SM 33x2,0 WD	708.1671.550.31	400	33x2.0	66.0	18.0	46	41	494
EGKO-30SM 42x2,0 WD	708.1671.590.31	400	42x2.0	70.5	20.0	50	50	674
EGKO-38SM 48x2,0 WD	708.1671.954.31	315	48x2.0	81.5	22.0	60	55	931

Baumaße sind Ungefährmaße bei angezogener Überwurfmutter.

Sizes are approximate dimensions at tightened nut.

Las medidas son aproximadas con la tuerca de unión apretada.

Dichtungsmaterial: FKM

Sealing material: FKM

Material de junta tórica: FKM.

**ISO 8434-1-SWOSDS**

**Gerade Einschraubstutzen NPT mit Dichtkegel und O-Ring**  
**Straight male adaptor unions NPT with taper and O-ring**  
**Racores para roscar NPT rectos con junta cónica y junta tórica**

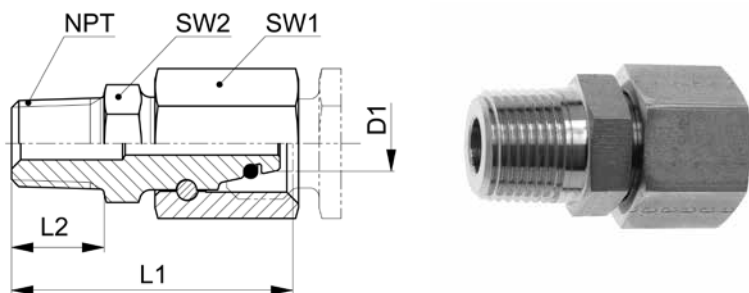

10

**EGKO-..LNPT/SNPT**

Type-D1 NPT	Mat.-Nr.	PN	NPT	L1	L2	SW1	SW2	g/Stk
NPT=Einschraubgewinde NPT		NPT=tapered male adaptor thread NPT			NPT=rosca de conexión cónica NPT			
EGKO-06LNPT 1.8	708.1672.100.21	315	1/8	30.5	10.0	17	11	37
EGKO-08LNPT 1.4	708.1672.170.21	315	1/4	37.5	14.0	17	14	69
EGKO-10LNPT 1.4	708.1672.270.21	315	1/4	38.0	14.0	19	14	59
EGKO-12LNPT 3.8	708.1672.390.21	315	3/8	40.0	17.0	22	19	102
EGKO-12LNPT 1.2	708.1672.400.21	315	1/2	45.0	19.0	22	22	118
EGKO-15LNPT 1.2	708.1672.534.21	315	1/2	49.5	19.0	27	22	159
EGKO-18LNPT 1.2	708.1672.646.21	315	1/2	49.0	26.0	32	27	158
EGKO-22LNPT 3.4	708.1672.768.21	160	3/4	52.0	20.0	36	27	216
EGKO-28LNPT 1.1	708.1672.850.21	160	1	61.0	25.0	46	36	383
EGKO-35LNPT 5.4	708.1672.944.21	160	1 1/4	65.5	26.0	50	46	505
EGKO-42LNPT 3.2	708.1672.992.21	160	1 1/2	68.5	26.0	60	50	770
EGKO-06SNPT 1.4	708.1672.110.31	630	1/4	37.5	14.0	17	14	61
EGKO-08SNPT 1.4	708.1672.170.31	630	1/4	38.0	14.0	19	17	62
EGKO-10SNPT 3.8	708.1672.280.31	630	3/8	40.5	26.0	22	19	90
EGKO-12SNPT 3.8	708.1672.390.31	630	3/8	42.0	14.0	24	19	95
EGKO-14SNPT 1.2	708.1672.504.31	630	1/2	50.5	19.0	27	22	177
EGKO-16SNPT 1.2	708.1672.566.31	400	1/2	51.0	19.0	30	24	236
EGKO-20SNPT 3.4	708.1672.708.31	400	3/4	54.0	26.0	36	27	283
EGKO-25SNPT 1.1	708.1672.810.31	400	1	63.5	25.0	46	36	504
EGKO-30SNPT 5.4	708.1672.902.31	400	1 1/4	70.0	26.0	50	46	650
EGKO-38SNPT 3.2	708.1672.953.31	315	1 1/2	73.0	26.0	60	50	932

Baumaße sind Ungefährmaße bei angezogener Überwurfmutter.

Sizes are approximate dimensions at tightened nut.

Las medidas son aproximadas con la tuerca de unión apretada.

Dichtungsmaterial: FKM

Sealing material: FKM

Material de junta tórica: FKM.

**Einschraubstutzen mit Schaft**

Abdichtung durch Dichtkante Form B nach DIN 3852-2

**Male adaptor standpipe connectors**

sealing edge form B acc. DIN 3852-2

**Cuerpos para roscar con vástago**

cierre hermético con borde de obturación forma B según DIN 3852-2

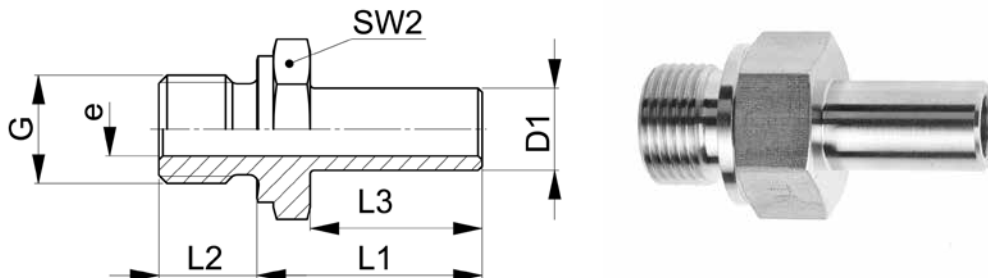

**XESS-..LR/SR**

Type-D1 G	Mat.-Nr.	PN	G	L1	L2	L3	SW2	e	g/Stk
G=Rohrgewinde (zylindrisch)		G=BSP thread (parallel)			G=rosca de conexión (cilíndrica)				
XESS-08LR/SR 1.4	706.1623.170.13	500	1/4	29.5	12.0	21.0	19	5.0	34
XESS-10LR/SR 1.4	706.1623.270.13	500	1/4	27.5	12.0	22.0	19	6.5	27
XESS-10LR/SR 3.8	706.1623.280.13	500	3/8	32.0	12.0	22.0	22	6.5	52
XESS-12LR/SR 1.4	706.1623.380.13	400	1/4	28.5	12.0	22.5	19	7.5	31
XESS-12LR/SR 3.8	706.1623.390.13	400	3/8	34.0	12.0	22.5	22	7.5	59
XESS-12LR/SR 1.2	706.1623.400.13	400	1/2	34.5	14.0	22.5	27	7.5	93
XESS-06LR 1.8	706.1623.100.20	500	1/8	24.5	8.0	19.5	14	3.0	13
XESS-15LR 3.8	706.1623.532.20	400	3/8	32.0	12.0	22.0	22	10.0	55
XESS-15LR 1.2	706.1623.534.20	400	1/2	32.0	14.0	22.0	27	10.0	84
XESS-18LR 1.2	706.1623.646.20	400	1/2	31.5	14.0	23.0	27	13.0	73
XESS-22LR 3.4	706.1623.768.20	250	3/4	32.5	16.0	24.5	32	16.0	115
XESS-28LR 3.4	706.1623.845.20	250	3/4	35.0	16.0	25.0	32	22.0	118
XESS-28LR 1.1	706.1623.850.20	250	1	35.0	18.0	25.0	41	22.0	186
XESS-35LR 5.4	706.1623.944.20	250	1 1/4	42.5	20.0	30.0	50	28.0	338
XESS-42LR 3.2	706.1623.992.20	250	1 1/2	46.5	22.0	30.5	55	34.0	468
XESS-06SR 1.4	706.1623.110.30	800	1/4	27.0	12.0	20.0	19	3.0	30
XESS-14SR 1.2	706.1623.504.30	630	1/2	37.0	14.0	24.0	27	9.0	101
XESS-16SR 1.2	706.1623.566.30	630	1/2	37.0	14.0	25.0	27	10.5	97
XESS-16SR 3.4	706.1623.568.30	630	3/4	35.0	16.0	25.0	32	10.5	138
XESS-20SR 3.4	706.1623.704.30	420	3/4	43.0	16.0	30.0	32	14.0	157
XESS-25SR 1.1	706.1623.810.30	420	1	48.0	18.0	33.0	41	17.0	291
XESS-30SR 1.1	706.1623.900.30	420	1	53.0	18.0	35.5	41	22.0	290
XESS-30SR 5.4	706.1623.902.30	420	1 1/4	51.0	20.0	35.5	50	22.0	451
XESS-38SR 3.2	706.1623.953.30	420	1 1/2	60.0	22.0	40.0	55	28.0	650

**Einschraubstutzen mit Schaft**

schaftseitig vormontiert, Abdichtung durch Dichtkante Form B nach DIN 3852-2

**Male adaptor standpipe unions**

pre-assembled on standpipe side, sealing edge form B acc. DIN 3852-2

**Racores para roscar con vástago**

premontado en lado de vástago, cierre hermético con junta de obturación forma B según DIN 3852-2

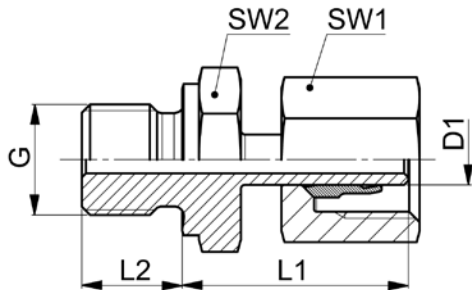

10

**ESS-..LR/SR**

Type-D1 G	Mat.-Nr.	PN	G	L1	L2	SW1	SW2	g/Stk
G=Rohrgewinde (zylindrisch)		G=BSP thread (parallel)			G=rosca de conexión (cilíndrica)			
ESS-06LR 1.8	708.1623.100.20	500	1/8	24.5	8.0	14	14	25
ESS-08LR 1.4	708.1623.170.20	500	1/4	29.5	12.0	17	19	47
ESS-10LR 1.4	708.1623.270.20	500	1/4	27.5	12.0	19	19	49
ESS-10LR 3.8	708.1623.280.20	500	3/8	27.5	12.0	19	22	64
ESS-12LR 1.4	708.1623.380.20	400	1/4	34.0	12.0	22	19	72
ESS-12LR 3.8	708.1623.390.20	400	3/8	34.0	12.0	22	22	74
ESS-12LR 1.2	708.1623.400.20	400	1/2	34.0	14.0	22	27	124
ESS-15LR 3.8	708.1623.532.20	400	3/8	32.0	12.0	27	22	100
ESS-15LR 1.2	708.1623.534.20	400	1/2	32.0	14.0	27	27	107
ESS-18LR 1.2	708.1623.646.20	400	1/2	31.5	14.0	32	27	140
ESS-22LR 3.4	708.1623.768.20	250	3/4	32.5	16.0	36	32	188
ESS-28LR 3.4	708.1623.845.20	250	3/4	35.0	16.0	41	32	217
ESS-28LR 1.1	708.1623.850.20	250	1	35.0	18.0	41	41	264
ESS-35LR 5.4	708.1623.944.20	250	1 1/4	42.5	20.0	50	50	438
ESS-42LR 3.2	708.1623.992.20	250	1 1/2	46.5	22.0	60	55	630
ESS-06SR 1.4	708.1623.110.30	800	1/4	27.0	12.0	17	19	42
ESS-08SR 1.4	708.1623.170.30	800	1/4	29.5	12.0	19	19	58
ESS-10SR 1.4	708.1623.270.30	800	1/4	29.5	12.0	22	19	66
ESS-10SR 3.8	708.1623.280.30	800	3/8	32.0	12.0	22	22	81
ESS-12SR 1.4	708.1623.380.30	630	1/4	34.0	12.0	24	19	72
ESS-12SR 3.8	708.1623.390.30	630	3/8	34.0	12.0	24	22	110
ESS-12SR 1.2	708.1623.400.30	630	1/2	32.0	14.0	24	27	127
ESS-14SR 1.2	708.1623.504.30	630	1/2	37.0	14.0	27	27	142
ESS-16SR 1.2	708.1623.566.30	630	1/2	37.0	14.0	30	27	160
ESS-16SR 3.4	708.1623.568.30	630	3/4	35.0	16.0	30	32	211
ESS-20SR 3.4	708.1623.704.30	420	3/4	43.0	16.0	36	32	261
ESS-25SR 1.1	708.1623.810.30	420	1	48.0	18.0	46	41	480
ESS-30SR 1.1	708.1623.900.30	420	1	53.0	18.0	50	41	533
ESS-30SR 5.4	708.1623.902.30	420	1 1/4	51.0	20.0	50	50	675
ESS-38SR 3.2	708.1623.953.30	420	1 1/2	60.0	22.0	60	55	1013

Achtung: Endmontage des vormontierten Schaftes wird erst nach 1/4 Umdrehung der Überwurfmutter über den Punkt des deutlich fühlbaren Kraftanstiegs erreicht.

Attention: Final standpipe assembly, the nut will be tightened at least by 1/4 of a turn beyond the point of a noticeable increase in force.

Atención: El montaje del vástago premontado se completa girando 1/4 vuelta la tuerca de unión a partir del punto en que aumenta claramente la resistencia.

**Einschraubstutzen mit Schaft**

Abdichtung durch Profildichtring Form E nach ISO 1179-2

**Male adaptor standpipe connectors**

profile sealing ring form E acc. ISO 1179-2

**Cuerpos para roscar con vástago**

cierre hermético mediante junta con perfil forma E según ISO 1179-2

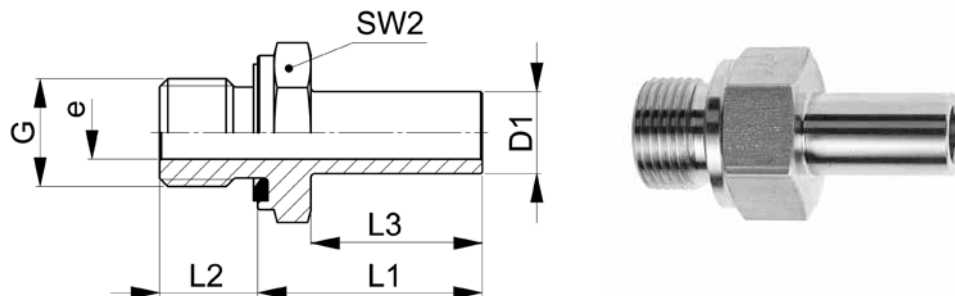

**XESS-..LR WD/SR WD**

Type-D1 G	Mat.-Nr.	PN	G	L1	L2	L3	SW2	e	g/Stk
G=Rohrgewinde (zylindrisch)		G=BSP thread (parallel)			G=rosca de conexión (cilíndrica)				
XESS-08LR/SR 1.4 WD	707.1624.170.13	500	1/4	29.5	12.0	21.0	19	5.0	33
XESS-10LR/SR 1.4 WD	707.1624.270.13	500	1/4	27.5	12.0	22.0	19	6.5	26
XESS-10LR/SR 3.8 WD	707.1624.280.13	500	3/8	32.0	12.0	22.0	22	6.5	51
XESS-12LR/SR 1.4 WD	707.1624.380.13	400	1/4	28.5	12.0	22.5	19	7.5	30
XESS-12LR/SR 3.8 WD	707.1624.390.13	400	3/8	34.0	12.0	22.5	22	7.5	58
XESS-12LR/SR 1.2 WD	707.1624.400.13	400	1/2	34.5	14.0	22.5	27	7.5	93
XESS-06LR 1.8 WD	707.1624.100.20	500	1/8	24.5	8.0	19.5	14	3.0	13
XESS-15LR 3.8 WD	707.1624.532.20	400	3/8	32.0	12.0	22.0	22	10.0	54
XESS-15LR 1.2 WD	707.1624.534.20	400	1/2	32.0	14.0	22.0	27	10.0	84
XESS-18LR 1.2 WD	707.1624.646.20	400	1/2	31.5	14.0	23.0	27	13.0	73
XESS-22LR 3.4 WD	707.1624.768.20	250	3/4	32.5	16.0	24.5	32	16.0	113
XESS-22LR 1.1 WD	707.1624.770.20	250	1	37.5	18.0	24.5	41	16.0	235
XESS-28LR 3.4 WD	707.1624.845.20	250	3/4	35.0	16.0	25.0	32	19.0	116
XESS-28LR 1.1 WD	707.1624.850.20	250	1	35.0	18.0	25.0	41	22.0	183
XESS-35LR 5.4 WD	707.1624.944.20	250	1 1/4	42.5	20.0	30.0	50	28.0	334
XESS-42LR 3.2 WD	707.1624.992.20	250	1 1/2	46.5	22.0	30.5	55	34.0	462
XESS-06SR 1.4 WD	707.1624.110.30	800	1/4	27.0	12.0	20.0	19	3.0	29
XESS-14SR 1.2 WD	707.1624.504.30	630	1/2	37.0	14.0	24.0	27	9.0	100
XESS-16SR 1.2 WD	707.1624.566.30	630	1/2	37.0	14.0	25.0	27	10.5	96
XESS-16SR 3.4 WD	707.1624.568.30	630	3/4	35.0	16.0	25.0	32	10.5	136
XESS-20SR 3.4 WD	707.1624.704.30	420	3/4	43.0	16.0	30.0	32	14.0	155
XESS-25SR 1.1 WD	707.1624.810.30	420	1	48.0	18.0	33.0	41	17.0	288
XESS-30SR 5.4 WD	707.1624.902.30	420	1 1/4	51.0	20.0	35.5	50	22.0	447
XESS-38SR 3.2 WD	707.1624.953.30	420	1 1/2	60.0	22.0	40.0	55	28.0	663

Dichtungsmaterial: FKM

Sealing material: FKM

Material de junta tórica: FKM

**Einschraubstutzen mit Schaft**

schaftseitig vormontiert, Abdichtung durch Profildichtring Form E nach ISO 1179-2

**Male adaptor standpipe unions**

pre-assembled on standpipe side, profile sealing ring form E acc. ISO 1179-2

**Racores para roscar con vástago**

premontado en lado de vástago, junta con anillo perfilado elástico forma E según ISO 1179-2

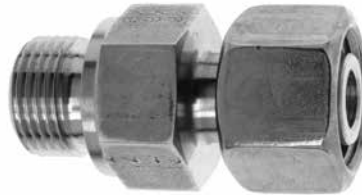
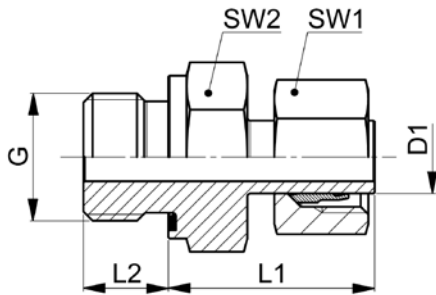

10

**ESS-..LR WD/SR WD**

Type-D1 G	Mat.-Nr.	PN	G	L1	L2	SW1	SW2	g/Stk
G=Rohrgewinde (zylindrisch)		G=BSP thread (parallel)			G=rosca de conexión (cilíndrica)			
ESS-06LR 1.8 WD	708.1624.100.20	500	1/8	24.5	8.0	14	14	25
ESS-08LR 1.4 WD	708.1624.170.20	500	1/4	29.5	12.0	17	19	47
ESS-10LR 1.4 WD	708.1624.270.20	500	1/4	27.5	12.0	19	19	49
ESS-10LR 3.8 WD	708.1624.280.20	500	3/8	27.5	12.0	19	22	62
ESS-12LR 1.4 WD	708.1624.380.20	400	1/4	34.0	12.0	22	19	58
ESS-12LR 3.8 WD	708.1624.390.20	400	3/8	34.0	12.0	22	22	74
ESS-12LR 1.2 WD	708.1624.400.20	400	1/2	34.0	14.0	22	27	108
ESS-15LR 3.8 WD	708.1624.532.20	400	3/8	32.0	12.0	27	22	90
ESS-15LR 1.2 WD	708.1624.534.20	400	1/2	32.0	14.0	27	27	107
ESS-18LR 1.2 WD	708.1624.646.20	400	1/2	31.5	14.0	32	27	140
ESS-22LR 3.4 WD	708.1624.768.20	250	3/4	32.5	16.0	36	32	188
ESS-22LR 1.1 WD	708.1624.770.20	250	1	37.5	18.0	36	41	322
ESS-28LR 3.4 WD	708.1624.845.20	250	3/4	35.0	16.0	41	32	232
ESS-28LR 1.1 WD	708.1624.850.20	250	1	35.0	18.0	41	41	264
ESS-35LR 5.4 WD	708.1624.944.20	250	1 1/4	42.5	20.0	50	50	438
ESS-42LR 3.2 WD	708.1624.992.20	250	1 1/2	46.5	22.0	60	55	630
ESS-06SR 1.4 WD	708.1624.110.30	800	1/4	27.0	12.0	17	19	42
ESS-08SR 1.4 WD	708.1624.170.30	800	1/4	29.5	12.0	19	19	58
ESS-10SR 1.4 WD	708.1624.270.30	800	1/4	32.0	12.0	22	19	50
ESS-10SR 3.8 WD	708.1624.280.30	800	3/8	32.0	12.0	22	22	81
ESS-12SR 1.4 WD	708.1624.380.30	630	1/4	34.0	12.0	24	19	78
ESS-12SR 3.8 WD	708.1624.390.30	630	3/8	34.0	12.0	24	22	110
ESS-12SR 1.2 WD	708.1624.400.30	630	1/2	32.0	14.0	24	27	127
ESS-14SR 1.2 WD	708.1624.504.30	630	1/2	37.0	14.0	27	27	142
ESS-16SR 1.2 WD	708.1624.566.30	630	1/2	37.0	14.0	30	27	160
ESS-16SR 3.4 WD	708.1624.568.30	630	3/4	35.0	16.0	30	32	211
ESS-20SR 3.4 WD	708.1624.704.30	420	3/4	43.0	16.0	36	32	261
ESS-25SR 1.1 WD	708.1624.810.30	420	1	48.0	18.0	46	41	480
ESS-30SR 5.4 WD	708.1624.902.30	420	1 1/4	51.0	20.0	50	50	675
ESS-38SR 3.2 WD	708.1624.953.30	420	1 1/2	60.0	22.0	60	55	899

Achtung: Endmontage des vormontierten Schaftes wird erst nach 1/4 Umdrehung der Überwurfmutter über den Punkt des deutlich fühlbaren Kraftanstiegs erreicht.

Attention: Final standpipe assembly, the nut will be tightened at least by 1/4 of a turn beyond the point of a noticeable increase in force.

Atención: El montaje del vástago premontado se completa girando 1/4 vuelta la tuerca de unión a partir del punto en que aumenta claramente la resistencia.

Dichtungsmaterial: FKM

Sealing material: FKM

Material de junta tórica: FKM

**Einschraubstutzen mit Schaft**

Abdichtung durch Dichtkante Form B nach DIN 3852-2

**Male adaptor standpipe connectors**

sealing edge form B acc. DIN 3852-2

**Cuerpos para roscar con vástago**

cierre hermético con borde de obturación forma B según DIN 3852-2

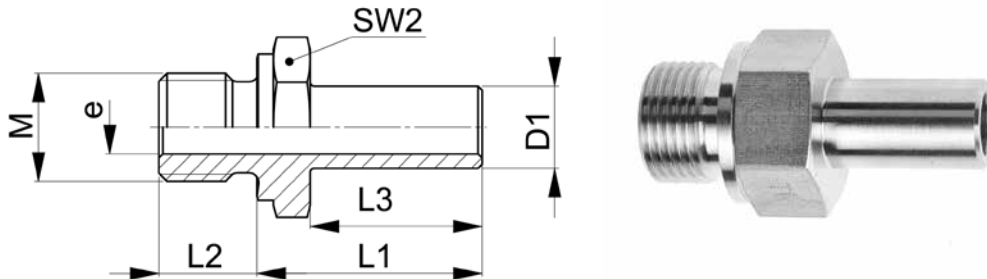

**XESS-..LM/SM**

Type-D1 M	Mat.-Nr.	PN	M	L1	L2	L3	SW2	e	g/Stk
M=metrisches Gewinde (zylindrisch)		M=metric thread (parallel)				M=rosca métrica (cilíndrica)			
XESS-06LM 10x1,0	706.1622.180.20	500	10x1.0	24.5	8.0	19.5	14	3.2	13
XESS-08LM 12x1,5	706.1622.240.20	500	12x1.5	29.5	12.0	21.0	17	5.0	28
XESS-10LM 14x1,5	706.1622.278.20	500	14x1.5	27.5	12.0	21.0	19	6.5	31
XESS-12LM 16x1,5	706.1622.330.20	400	16x1.5	34.0	12.0	21.0	22	8.0	60
XESS-15LM 18x1,5	706.1622.390.20	400	18x1.5	34.0	12.0	22.0	24	10.0	70
XESS-18LM 22x1,5	706.1622.460.20	400	22x1.5	31.5	14.0	23.0	27	13.0	79
XESS-22LM 26x1,5	706.1622.535.20	250	26x1.5	32.5	16.0	24.5	32	16.0	114
XESS-06SM 12x1,5	706.1622.190.30	800	12x1.5	27.0	12.0	20.0	17	3.2	25
XESS-12SM 18x1,5	706.1622.333.30	630	18x1.5	34.0	12.0	22.5	24	7.0	71
XESS-16SM 22x1,5	706.1622.410.30	630	22x1.5	37.0	14.0	25.0	27	10.5	103
XESS-25SM 33x2,0	706.1622.550.30	420	33x2.0	48.0	18.0	33.0	41	17.0	292

**Einschraubstutzen mit Schaft**

schaftseitig vormontiert, Abdichtung durch Dichtkante Form B nach DIN 3852-2

**Male adaptor standpipe unions**

pre-assembled on standpipe side, sealing edge form B acc. DIN 3852-2

**Racores para roscar con vástago**

premontado en lado de vástago, cierre hermético mediante borde de obturación forma B según DIN 3852-2

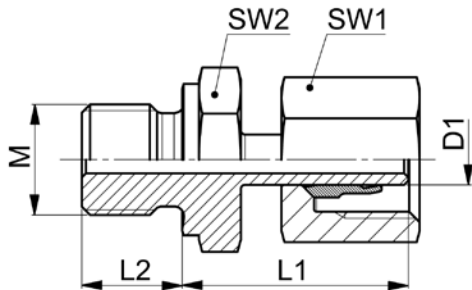

10

**ESS-..LM/SM**

Type-D1 M	Mat.-Nr.	PN	M	L1	L2	SW1	SW2	g/Stk
M=metrisches Gewinde (zylindrisch)	M=metric thread (parallel)	M=rosca métrica (cilíndrica)						
ESS-06LM 10x1,0	708.1622.180.20	500	10x1.0	24.5	8.0	14	14	29
ESS-08LM 12x1,5	708.1622.240.20	500	12x1.5	29.5	12.0	17	17	38
ESS-10LM 14x1,5	708.1622.278.20	500	14x1.5	27.5	12.0	19	19	50
ESS-12LM 16x1,5	708.1622.330.20	400	16x1.5	34.0	12.0	22	22	65
ESS-15LM 18x1,5	708.1622.390.20	400	18x1.5	34.0	12.0	27	24	100
ESS-18LM 22x1,5	708.1622.460.20	400	22x1.5	31.5	14.0	32	27	140
ESS-22LM 26x1,5	708.1622.535.20	250	26x1.5	32.5	16.0	36	32	188
ESS-06SM 12x1,5	708.1622.190.30	800	12x1.5	27.0	12.0	17	17	40
ESS-12SM 18x1,5	708.1622.333.30	630	18x1.5	34.0	12.0	24	24	111
ESS-16SM 22x1,5	708.1622.410.30	630	22x1.5	37.0	14.0	30	27	168
ESS-25SM 33x2,0	708.1622.550.30	420	33x2.0	48.0	18.0	46	41	480

Achtung: Endmontage des vormontierten Schaftes wird erst nach 1/4 Umdrehung der Überwurfmutter über den Punkt des deutlich fühlbaren Kraftanstiegs erreicht.

Attention: Final standpipe assembly, the nut will be tightened at least by 1/4 of a turn beyond the point of a noticeable increase in force.

Atención: El montaje del vástago premontado se completa girando 1/4 vuelta la tuerca de unión a partir del punto en que aumenta claramente la resistencia.

**Einschraubstutzen mit Schaft**

Abdichtung durch Profildichtring Form E nach ISO 1179-2

**Male adaptor standpipe connectors**

profile sealing ring form E acc. ISO 1179-2

**Cuerpos para roscar con vástago**

cierre hermético mediante junta con perfil forma E según ISO 1179-2

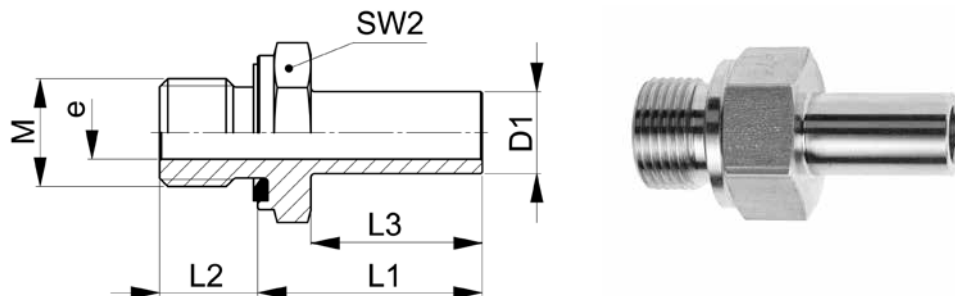

**XESS-..LM WD / SM WD**

Type-D1 M	Mat.-Nr.	PN	M	L1	L2	L3	SW2	e	g/Stk
M=metrisches Gewinde (zylindrisch)	M=metric thread (parallel)					M=rosca métrica (cilíndrica)			
XESS-06LM 10x1,0 WD	707.1625.180.20	500	10x1.0	24.5	8.0	19.5	14	3.2	13
XESS-10LM 14x1,5 WD	707.1625.278.20	500	14x1.5	27.5	12.0	21.0	19	6.5	30
XESS-12LM 16x1,5 WD	707.1625.330.20	400	16x1.5	34.0	12.0	21.0	22	8.0	59
XESS-15LM 18x1,5 WD	707.1625.390.20	400	18x1.5	34.0	12.0	22.0	24	10.0	69
XESS-18LM 22x1,5 WD	707.1625.460.20	400	22x1.5	31.5	14.0	23.0	27	13.0	78
XESS-22LM 26x1,5 WD	707.1625.535.20	250	26x1.5	32.5	16.0	24.5	32	16.0	113
XESS-28LM 33x2,0 WD	707.1625.570.20	250	33x2.0	35.0	18.0	25.0	41	22.0	176
XESS-35LM 42x2,0 WD	707.1625.600.20	250	42x2.0	42.5	20.0	30.0	50	28.0	338
XESS-42LM 48x2,0 WD	707.1625.992.20	250	48x2.0	46.5	22.0	30.5	55	34.0	467
XESS-06SM 12x1,5 WD	707.1625.190.30	800	12x1.5	27.0	12.0	20.0	17	3.2	24
XESS-08SM 14x1,5 WD	707.1625.245.30	800	14x1.5	29.5	12.0	21.0	19	4.3	36
XESS-10SM 16x1,5 WD	707.1625.285.30	800	16x1.5	32.0	12.0	22.0	22	6.0	52
XESS-12SM 18x1,5 WD	707.1625.333.30	630	18x1.5	34.0	12.0	22.5	24	7.0	71
XESS-14SM 20x1,5 WD	707.1625.382.30	630	20x1.5	37.0	14.0	24.0	27	9.0	98
XESS-16SM 22x1,5 WD	707.1625.410.30	630	22x1.5	37.0	14.0	25.0	27	10.5	102
XESS-20SM 27x2,0 WD	707.1625.506.30	420	27x2.0	43.0	16.0	30.0	32	14.0	157
XESS-25SM 33x2,0 WD	707.1625.550.30	420	33x2.0	48.0	18.0	33.0	41	17.0	289
XESS-30SM 42x2,0 WD	707.1625.590.30	420	42x2.0	51.0	20.0	35.5	50	22.0	450
XESS-38SM 48x2,0 WD	707.1625.954.30	420	48x2.0	60.0	22.0	40.0	55	28.0	668

Dichtungsmaterial: FKM

Sealing material: FKM

Material de junta tórica: FKM

**Einschraubstutzen mit Schaft**

schaftseitig vormontiert, Abdichtung durch Profildichtring Form E nach ISO 1179-2

**Male adaptor standpipe unions**

pre-assembled on standpipe side, profile sealing ring form E acc. ISO 1179-2

**Racores para roscar con vástago**

premontado en lado de vástago, cierre hermético mediante junta con perfil forma E según ISO 1179-2

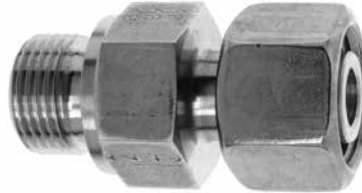
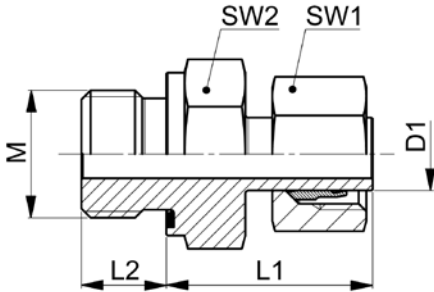

10

**ESS-..LM WD/SM WD**

Type-D1 M	Mat.-Nr.	PN	M	L1	L2	SW1	SW2	g/Stk
M=metrisches Gewinde (zylindrisch)	M=metric thread (parallel)	M=rosca métrica (cilindrica)						
ESS-06LM 10x1,0 WD	708.1625.180.20	500	10x1.0	24.5	8.0	14	14	29
ESS-10LM 14x1,5 WD	708.1625.278.20	500	14x1.5	27.5	12.0	19	19	50
ESS-12LM 16x1,5 WD	708.1625.330.20	400	16x1.5	34.0	12.0	22	22	65
ESS-15LM 18x1,5 WD	708.1625.390.20	400	18x1.5	34.0	12.0	27	24	100
ESS-18LM 22x1,5 WD	708.1625.460.20	400	22x1.5	31.5	14.0	32	27	140
ESS-22LM 26x1,5 WD	708.1625.535.20	250	26x1.5	32.5	16.0	36	32	188
ESS-28LM 33x2,0 WD	708.1625.570.20	250	33x2.0	35.0	18.0	41	41	264
ESS-35LM 42x2,0 WD	708.1625.600.20	250	42x2.0	42.5	20.0	50	50	466
ESS-42LM 48x2,0 WD	708.1625.992.20	250	48x2.0	46.5	22.0	60	55	628
ESS-06SM 12x1,5 WD	708.1625.190.30	800	12x1.5	27.0	12.0	17	17	40
ESS-08SM 14x1,5 WD	708.1625.245.30	800	14x1.5	29.5	12.0	19	19	58
ESS-10SM 16x1,5 WD	708.1625.285.30	800	16x1.5	32.0	12.0	22	22	80
ESS-12SM 18x1,5 WD	708.1625.333.30	630	18x1.5	34.0	12.0	24	24	111
ESS-14SM 20x1,5 WD	708.1625.382.30	630	20x1.5	37.0	14.0	27	27	140
ESS-16SM 22x1,5 WD	708.1625.410.30	630	22x1.5	37.0	14.0	30	27	168
ESS-20SM 27x2,0 WD	708.1625.506.30	420	27x2.0	43.0	16.0	36	32	261
ESS-25SM 33x2,0 WD	708.1625.550.30	420	33x2.0	48.0	18.0	46	41	480
ESS-30SM 42x2,0 WD	708.1625.590.30	420	42x2.0	51.0	20.0	50	50	671
ESS-38SM 48x2,0 WD	708.1625.954.30	420	48x2.0	60.0	22.0	60	55	867

Achtung: Endmontage des vormontierten Schaftes wird erst nach 1/4 Umdrehung der Überwurfmutter über den Punkt des deutlich fühlbaren Kraftanstiegs erreicht.

Attention: Final standpipe assembly, the nut will be tightened at least by 1/4 of a turn beyond the point of a noticeable increase in force.

Atención: El montaje del vástago premontado se completa girando 1/4 vuelta la tuerca de unión a partir del punto en que aumenta claramente la resistencia.

Dichtungsmaterial: FKM

Sealing material: FKM

Material de junta tórica: FKM

**Einschraubstutzen NPT mit Schaft**  
**Male adaptor NPT standpipe connectors**  
**Cuerpos para roscar con vástago NPT**

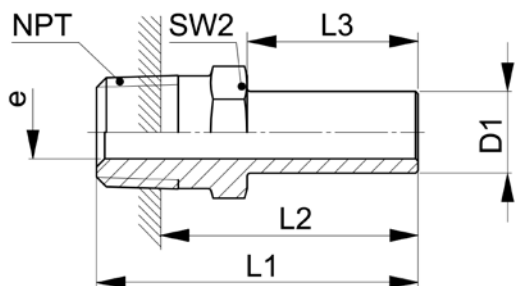

**XESS-..LNPT/SNPT**

Type-D1 NPT	Mat.-Nr.	PN	L1	L2	L3	SW2	e	g/Stk
NPT=Einschraubgewinde NPT		NPT=tapered male adaptor thread NPT				NPT=rosca de conexión cónica NPT		
XESS-08LNPT/SNPT 1.4	706.1602.170.13	500	40.5	30.5	21.0	14	5.0	26
XESS-10LNPT/SNPT 1.4	706.1602.270.13	500	40.5	30.5	22.0	14	6.5	25
XESS-12LNPT/SNPT 1.4	706.1602.380.13	400	45.0	35.0	22.5	14	7.5	30
XESS-12LNPT/SNPT 3.8	706.1602.390.13	400	45.0	35.0	22.5	19	7.5	44
XESS-12LNPT/SNPT 1.2	706.1602.400.13	400	48.0	34.0	22.5	22	7.5	73
XESS-06LNPT 1.8	706.1602.100.20	500	33.0	26.0	20.0	11	3.5	11
XESS-15LNPT 3.8	706.1602.532.20	400	45.0	35.0	22.0	19	10.0	51
XESS-15LNPT 1.2	706.1602.534.20	400	47.0	33.0	22.0	22	10.0	76
XESS-18LNPT 1.2	706.1602.646.20	400	49.0	35.0	23.0	22	13.0	72
XESS-22LNPT 3.4	706.1602.768.20	250	50.0	36.0	24.5	27	16.0	105
XESS-28LNPT 1.1	706.1602.850.20	250	60.0	42.0	25.0	36	22.0	200
XESS-35LNPT 5.4	706.1602.944.20	250	68.0	50.0	30.0	46	28.0	357
XESS-42LNPT 3.2	706.1602.992.20	250	68.5	50.5	30.5	50	34.0	420
XESS-10SNPT 3.8	706.1602.280.30	800	43.0	33.0	22.0	19	6.0	47
XESS-14SNPT 1.2	706.1602.504.30	630	50.0	36.0	24.0	22	9.0	80
XESS-16SNPT 1.2	706.1602.566.30	630	50.0	36.0	25.0	22	10.5	78
XESS-20SNPT 3.4	706.1602.704.30	420	59.0	45.0	30.0	27	14.0	132
XESS-25SNPT 1.1	706.1602.810.30	420	66.0	48.0	33.0	36	17.0	250
XESS-30SNPT 5.4	706.1602.902.30	420	71.0	53.0	35.5	46	22.0	408
XESS-38SNPT 3.2	706.1602.953.30	420	82.0	64.0	40.0	50	28.0	607

### Einschraubstutzen NPT mit Schaft

schaftseitig vormontiert

### Male adaptor NPT standpipe unions

pre-assembled on standpipe side

### Racores para roscar NPT con vástago

premontado en lado de vástago

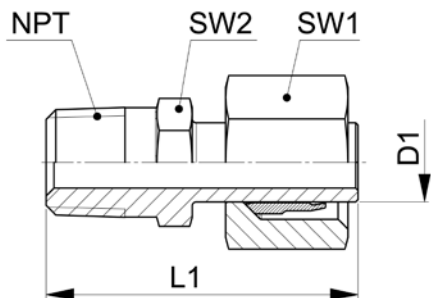

10

### ESS..LNPT/SNPT

Type-D1 NPT	Mat.-Nr.	PN	NPT	L1	SW1	SW2	g/Stk
NPT=Einschraubgewinde NPT		NPT=tapered male adaptor thread NPT		NPT=rosca de conexión cónica NPT			
ESS-06LNPT 1.8	708.1602.100.20	500	1/8	33.0	14	11	26
ESS-08LNPT 1.4	708.1602.170.20	500	1/4	40.5	17	14	54
ESS-10LNPT 1.4	708.1602.270.20	500	1/4	40.5	19	14	47
ESS-12LNPT 1.4	708.1602.380.20	400	1/4	45.0	22	14	52
ESS-12LNPT 3.8	708.1602.390.20	400	3/8	45.0	22	19	70
ESS-12LNPT 1.2	708.1602.400.20	400	1/2	48.0	22	22	114
ESS-15LNPT 3.8	708.1602.532.20	400	3/8	45.0	27	19	95
ESS-15LNPT 1.2	708.1602.534.20	400	1/2	47.0	27	22	109
ESS-18LNPT 1.2	708.1602.646.20	400	1/2	49.0	32	22	130
ESS-22LNPT 3.4	708.1602.768.20	250	3/4	50.0	36	27	185
ESS-28LNPT 1.1	708.1602.850.20	250	1	60.0	41	36	299
ESS-35LNPT 5.4	708.1602.944.20	250	1 1/4	68.0	50	46	405
ESS-42LNPT 3.2	708.1602.992.20	250	1 1/2	68.5	60	50	570
ESS-08SNPT 1.4	708.1602.170.30	800	1/4	40.5	19	14	56
ESS-10SNPT 1.4	708.1602.270.30	800	1/4	43.0	22	14	58
ESS-10SNPT 3.8	708.1602.280.30	800	3/8	43.0	22	19	80
ESS-12SNPT 1.4	708.1602.380.30	630	1/4	45.0	24	14	64
ESS-12SNPT 3.8	708.1602.390.30	630	3/8	45.0	24	19	80
ESS-12SNPT 1.2	708.1602.400.30	630	1/2	49.0	24	22	116
ESS-14SNPT 1.2	708.1602.504.30	630	1/2	50.0	27	22	145
ESS-16SNPT 1.2	708.1602.566.30	630	1/2	50.0	30	22	150
ESS-20SNPT 3.4	708.1602.704.30	420	3/4	59.0	36	27	255
ESS-25SNPT 1.1	708.1602.810.30	420	1	66.0	46	36	500
ESS-30SNPT 5.4	708.1602.902.30	420	1 1/4	71.0	50	46	620
ESS-38SNPT 3.2	708.1602.953.30	420	1 1/2	82.0	60	50	890

Achtung: Endmontage des vormontierten Schaftes wird erst nach 1/4 Umdrehung der Überwurfmutter über den Punkt des deutlich fühlbaren Kraftanstiegs erreicht.

Attention: Final standpipe assembly, the nut will be tightened at least by 1/4 of a turn beyond the point of a noticeable increase in force.

Atención: El montaje del vástago premontado se completa girando 1/4 vuelta la tuerca de unión a partir del punto en que aumenta claramente la resistencia.

**Einstellbare Winkelstutzen mit Dichtkegel und O-Ring**

dichtkegelseitig vormontiert

**Adjustable elbow connectors with taper and O-ring**

pre-assembled on tapered nipple side

**Cuerpos angulares ajustables con junta cónica y junta tórica**

premontado en lado de junta cónica

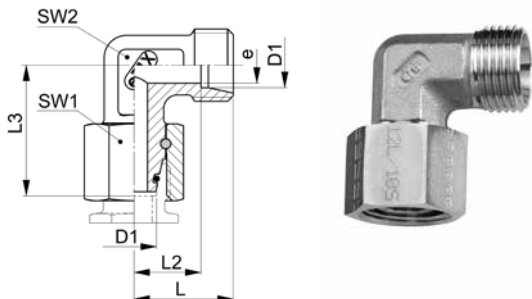

**XEWKO-..L/S M**

Type-D1	Mat.-Nr.	PN	L	L2	L3	SW1	SW2	e	g/Stk
XEWKO-06L M	707.2670.060.20	315	19.0	12.0	26.0	14	12	3.0	31
XEWKO-08L M	707.2670.080.20	315	21.0	14.0	27.5	17	12	4.0	42
XEWKO-10L M	707.2670.100.20	315	22.0	15.0	29.0	19	14	6.0	58
XEWKO-12L M	707.2670.120.20	315	24.0	17.0	29.5	22	17	8.0	77
XEWKO-15L M	707.2670.150.20	315	28.0	21.0	32.5	27	19	10.0	130
XEWKO-18L M	707.2670.180.20	315	31.0	23.5	35.5	32	24	13.0	180
XEWKO-22L M	707.2670.220.20	160	35.0	27.5	38.5	36	27	17.0	254
XEWKO-28L M	707.2670.280.20	160	38.0	30.5	41.5	41	36	22.0	371
XEWKO-35L M	707.2670.350.20	160	45.0	34.5	51.0	50	41	28.0	551
XEWKO-42L M	707.2670.420.20	160	51.0	40.0	56.0	60	50	34.0	868
XEWKO-06S M	707.2670.060.30	630	23.0	16.0	27.0	17	12	3.0	46
XEWKO-08S M	707.2670.080.30	630	24.0	17.0	27.5	19	14	4.0	65
XEWKO-10S M	707.2670.100.30	630	25.0	17.5	30.0	22	17	6.0	88
XEWKO-12S M	707.2670.120.30	630	29.0	21.5	31.0	24	17	8.0	106
XEWKO-14S M	707.2670.140.30	630	30.0	22.0	35.0	27	19	9.0	144
XEWKO-16S M	707.2670.160.30	400	33.0	24.5	36.5	30	24	11.0	196
XEWKO-20S M	707.2670.200.30	400	37.0	26.5	44.5	36	27	14.0	300
XEWKO-25S M	707.2670.250.30	400	42.0	30.0	50.0	46	36	18.0	539
XEWKO-30S M	707.2670.350.30	400	49.0	35.5	55.0	50	41	23.0	719
XEWKO-38S M	707.2670.380.30	315	57.0	41.0	63.0	60	50	30.0	1094

Dichtungsmaterial: FKM

Sealing material: FKM

Material de junta tórica: FKM

**ISO 8434-1-SWOE**

**Einstellbare Winkelverschraubungen mit Dichtkegel und O-Ring**  
**Adjustable elbow fittings with taper and O-ring**  
**Racores angulares ajustables con junta cónica y junta tórica**

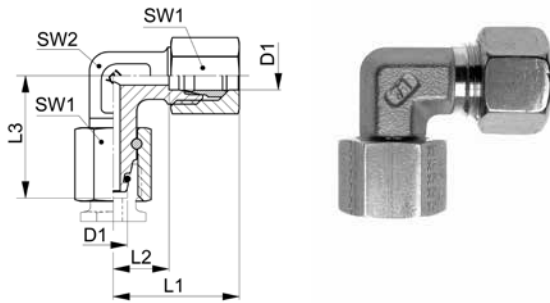

10

**EWKO-..L/S**

Type -D1	Mat.-Nr.	PN	L1	L2	L3	SW1	SW2	g/Stk
EWKO-06L	708.2670.060.20	315	27.0	12.0	26.0	14	12	43
EWKO-08L	708.2670.080.20	315	29.0	14.0	27.5	17	12	59
EWKO-10L	708.2670.100.20	315	30.5	15.0	29.0	19	14	80
EWKO-12L	708.2670.120.20	315	32.0	17.0	29.5	22	17	105
EWKO-15L	708.2670.150.20	315	36.0	21.0	32.5	27	19	175
EWKO-18L	708.2670.180.20	315	40.0	23.5	32.5	32	24	248
EWKO-22L	708.2670.220.20	160	44.0	27.5	38.5	36	27	344
EWKO-28L	708.2670.280.20	160	47.0	30.5	41.5	41	36	476
EWKO-35L	708.2670.350.20	160	56.0	34.5	51.0	50	41	715
EWKO-42L	708.2670.420.20	160	63.0	40.0	56.0	60	50	1121
EWKO-06S	708.2670.060.30	630	31.0	16.0	27.0	17	12	64
EWKO-08S	708.2670.080.30	630	32.0	17.0	27.5	19	14	86
EWKO-10S	708.2670.100.30	630	34.0	17.5	30.0	22	17	120
EWKO-12S	708.2670.120.30	630	38.0	21.5	31.0	24	17	143
EWKO-14S	708.2670.140.30	630	40.0	22.0	35.0	27	19	188
EWKO-16S	708.2670.160.30	400	43.0	24.5	36.5	30	24	265
EWKO-20S	708.2670.200.30	400	48.0	26.5	44.5	36	27	412
EWKO-25S	708.2670.250.30	400	54.0	30.0	50.0	46	36	763
EWKO-30S	708.2670.350.30	400	62.0	35.5	55.0	50	41	968
EWKO-38S	708.2670.380.30	315	72.0	41.0	63.0	60	50	1458

Baumaße sind Ungefährmaße bei angezogener Überwurfmutter.

Sizes are approximate dimensions at tightened nut.

Las medidas son aproximadas con la tuerca de unión apretada.

Dichtungsmaterial: FKM

Sealing material: FKM

Material de junta tórica: FKM.

**ISO 8434-1-SWOEC**

## Einstellbare Winkel-Einschraubverschraubungen mit Dichtkegel und O-Ring

mit Einschraubstutzen, Abdichtung durch Dichtkante Form B nach DIN 3852-2

## Adjustable male adaptor elbow fittings with taper and O-ring

with male adaptor connector, sealing edge form B acc. DIN 3852-2

## Racores para roscar en codo ajustables con junta cónica y junta tórica

con racor para roscar, cierre hermético mediante borde de obturación forma B según DIN 3852-2

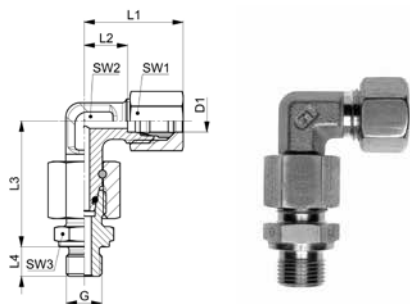

### EWKO-..LR/SR

Type-D1 G	Mat.-Nr.	PN	G	L1	L2	L3	L4	SW1	SW2	SW3	g/Stk	
G=Rohrgewinde (zylindrisch)		G=BSP thread (parallel)					G=rosca de conexión (cilíndrica)					
EWKO-06LR 1.8	708.2671.100.20	315	1/8	27.0	12.0	34.5	8.0	14	12	14	57	
EWKO-08LR 1.4	708.2671.170.20	315	1/4	29.0	14.0	37.0	12.0	17	12	19	87	
EWKO-10LR 1.4	708.2671.270.20	315	1/4	30.5	15.0	39.5	12.0	19	14	19	109	
EWKO-12LR 1.4	708.2671.380.20	315	1/4	32.0	17.0	41.5	12.0	22	17	19	137	
EWKO-12LR 3.8	708.2671.390.20	315	3/8	32.0	17.0	42.0	12.0	22	17	22	147	
EWKO-12LR 1.2	708.2671.400.20	315	1/2	32.0	17.0	42.5	14.0	22	17	27	175	
EWKO-15LR 1.2	708.2671.534.20	315	1/2	36.0	21.0	46.5	14.0	27	19	27	248	
EWKO-18LR 1.2	708.2671.646.20	315	1/2	40.0	23.5	50.0	14.0	32	24	27	320	
EWKO-22LR 3.4	708.2671.768.20	160	3/4	44.0	27.5	55.0	16.0	36	27	32	450	
EWKO-28LR 1.1	708.2671.850.20	160	1	47.0	30.5	59.0	18.0	41	36	41	349	
EWKO-35LR 5.4	708.2671.944.20	160	1 1/4	56.0	34.5	68.5	20.0	50	41	50	996	
EWKO-42LR 3.2	708.2671.992.20	160	1 1/2	63.0	40.0	75.0	22.0	60	50	60	1482	
EWKO-06SR 1.4	708.2671.110.30	630	1/4	31.0	16.0	40.0	12.0	17	12	19	98	
EWKO-08SR 1.4	708.2671.170.30	630	1/4	32.0	17.0	42.0	12.0	19	14	19	128	
EWKO-10SR 3.8	708.2671.280.30	630	3/8	34.0	17.5	45.0	12.0	22	17	22	178	
EWKO-12SR 3.8	708.2671.390.30	630	3/8	38.0	21.5	48.0	12.0	24	17	22	207	
EWKO-12SR 1.2	708.2671.400.30	630	1/2	38.0	21.5	48.5	14.0	24	17	27	242	
EWKO-14SR 1.2	708.2671.504.30	630	1/2	40.0	22.0	54.0	14.0	27	19	27	287	
EWKO-16SR 1.2	708.2671.566.30	400	1/2	43.0	24.5	55.0	14.0	30	24	27	359	
EWKO-20SR 3.4	708.2671.704.30	400	3/4	48.0	26.5	65.0	14.0	36	27	27	567	
EWKO-25SR 1.1	708.2671.810.30	400	1	54.0	30.0	73.0	18.0	46	36	41	1036	
EWKO-30SR 5.4	708.2671.902.30	400	1 1/4	62.0	35.5	78.5	20.0	50	41	50	1398	
EWKO-38SR 3.2	708.2671.953.30	315	1 1/2	72.0	41.0	89.0	22.0	60	50	55	2037	

Baumaße sind Ungefährmaße bei angezogener Überwurfmutter.

Sizes are approximate dimensions at tightened nut.

Las medidas son aproximadas con la tuerca de unión apretada.

Dichtungsmaterial: FKM

Sealing material: FKM

Material de junta tórica: FKM.

## Einstellbare Winkel-Einschraubverschraubungen mit Dichtkegel und O-Ring

mit Einschraubstutzen, Abdichtung durch Profildichtring Form E nach ISO 1179-2

## Adjustable male adaptor elbow fittings with taper and O-ring

with male adaptor connector, profile sealing ring form E acc. ISO 1179-2

## Racores para roscar en codo ajustables con junta cónica y junta tórica

con racor para roscar, cierre hermético mediante junta con perfil forma E según ISO 1179-2

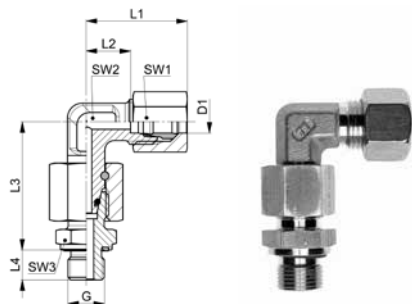

10

### EWKO-..LR WD/SR WD

Type-D1 G	Mat.-Nr.	PN	G	L1	L2	L3	L4	SW1	SW2	SW3	g/Stk	
G=Rohrgewinde (zylindrisch)		G=BSP thread (parallel)					G=rosca de conexión (cilíndrica)					
EWKO-06LR 1.8 WD	708.2672.100.20	315	1/8	27.0	12.0	34.0	8.0	14	12	14	57	
EWKO-08LR 1.4 WD	708.2672.170.20	315	1/4	29.0	14.0	37.0	12.0	17	12	19	86	
EWKO-10LR 1.4 WD	708.2672.270.20	315	1/4	30.5	15.0	40.0	12.0	19	14	19	108	
EWKO-12LR 1.4 WD	708.2672.380.20	315	1/4	32.0	17.0	41.5	12.0	22	17	19	134	
EWKO-12LR 3.8 WD	708.2672.390.20	315	3/8	32.0	17.0	42.0	12.0	22	17	22	147	
EWKO-12LR 1.2 WD	708.2672.400.20	315	1/2	32.0	17.0	42.5	14.0	22	17	27	175	
EWKO-15LR 1.2 WD	708.2672.534.20	315	1/2	36.0	21.0	43.5	14.0	27	19	27	248	
EWKO-18LR 1.2 WD	708.2672.646.20	315	1/2	40.0	23.5	50.0	14.0	32	24	27	320	
EWKO-22LR 3.4 WD	708.2672.768.20	160	3/4	44.0	27.5	55.0	16.0	36	27	32	448	
EWKO-28LR 1.1 WD	708.2672.850.20	160	1	47.0	30.5	59.0	18.0	41	36	41	645	
EWKO-35LR 5.4 WD	708.2672.944.20	160	1 1/4	56.0	34.5	68.0	20.0	50	41	50	995	
EWKO-42LR 3.2 WD	708.2672.992.20	160	1 1/2	63.0	40.0	75.5	22.0	60	50	55	1477	
EWKO-06SR 1.4 WD	708.2672.110.30	630	1/4	31.0	16.0	39.0	12.0	17	12	19	100	
EWKO-08SR 1.4 WD	708.2672.170.30	630	1/4	32.0	17.0	41.5	12.0	19	14	19	127	
EWKO-10SR 3.8 WD	708.2672.280.30	630	3/8	34.0	17.5	45.0	12.0	22	17	22	176	
EWKO-12SR 3.8 WD	708.2672.390.30	630	3/8	38.0	21.5	48.0	12.0	24	17	22	207	
EWKO-12SR 1.2 WD	708.2672.400.30	630	1/2	38.0	21.5	48.5	14.0	24	17	27	241	
EWKO-14SR 1.2 WD	708.2672.504.30	630	1/2	40.0	22.0	54.0	14.0	27	19	27	287	
EWKO-16SR 1.2 WD	708.2672.566.30	400	1/2	43.0	24.5	55.0	14.0	30	24	27	359	
EWKO-20SR 3.4 WD	708.2672.704.30	400	3/4	48.0	26.5	65.0	18.0	36	27	27	564	
EWKO-25SR 1.1 WD	708.2672.810.30	400	1	54.0	30.0	72.5	18.0	46	36	41	1033	
EWKO-30SR 5.4 WD	708.2672.944.30	400	1 1/4	62.0	35.5	78.5	18.0	50	41	50	1394	
EWKO-38SR 3.2 WD	708.2672.953.30	315	1 1/2	72.0	41.0	89.0	22.0	60	50	55	2033	

Baumaße sind Ungefährmaße bei angezogener Überwurfmutter.

Sizes are approximate dimensions at tightened nut.

Las medidas son aproximadas con la tuerca de unión apretada.

Dichtungsmaterial: FKM

Sealing material: FKM

Material de junta tórica: FKM.

**Einstellbare Winkelstutzen mit Schaft**

schaftseitig vormontiert

**Adjustable standpipe elbow connectors**

pre-assembled on standpipe side

**Cuerpos angulares ajustables con vástago**

premontado en lado de vástago

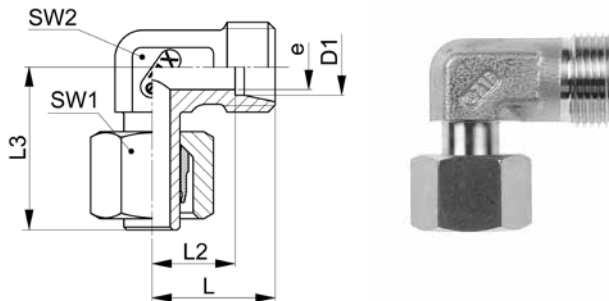

**XEWV-..L/S M**

Type-D1	Mat.-Nr.	PN	L	L2	L3	SW1	SW2	e	g/Stk
XEWV-06L M	707.2623.060.20	500	19.0	12.0	26.0	14	12	3.4	28
XEWV-08L M	707.2623.080.20	500	21.0	14.0	27.5	17	12	5.0	37
XEWV-10L M	707.2623.100.20	500	22.0	15.0	29.0	19	14	6.5	50
XEWV-12L M	707.2623.120.20	400	24.0	17.0	29.5	22	17	8.0	67
XEWV-15L M	707.2623.150.20	400	28.0	21.0	32.5	27	19	10.0	115
XEWV-18L M	707.2623.180.20	400	31.0	23.5	35.5	32	24	13.0	173
XEWV-22L M	707.2623.220.20	250	35.0	27.5	38.5	36	27	16.0	229
XEWV-28L M	707.2623.280.20	250	38.0	30.5	41.5	41	36	22.0	349
XEWV-35L M	707.2623.350.20	250	45.0	34.5	51.0	50	41	28.0	535
XEWV-42L M	707.2623.420.20	250	51.0	40.0	56.0	60	50	34.0	813
XEWV-06S M	707.2623.060.30	800	23.0	16.0	27.0	17	12	3.4	42
XEWV-08S M	707.2623.080.30	800	24.0	17.0	27.5	19	14	4.3	57
XEWV-10S M	707.2623.100.30	800	25.0	17.5	30.0	22	17	6.0	82
XEWV-12S M	707.2623.120.30	630	29.0	21.5	31.0	24	17	7.0	97
XEWV-14S M	707.2623.140.30	630	30.0	22.0	35.0	27	19	9.0	138
XEWV-16S M	707.2623.160.30	630	33.0	24.5	36.5	30	24	10.5	190
XEWV-20S M	707.2623.200.30	420	37.0	26.5	44.5	36	27	14.0	285
XEWV-25S M	707.2623.250.30	420	42.0	30.0	50.0	46	36	17.0	565
XEWV-30S M	707.2623.300.30	420	49.0	35.5	55.0	50	41	22.0	737
XEWV-38S M	707.2623.380.30	420	57.0	41.0	63.0	60	50	28.0	1155

Achtung: Endmontage des vormontierten Schaftes wird erst nach 1/4 Umdrehung der Überwurfmutter über den Punkt des deutlich fühlbaren Kraftanstiegs erreicht.

Attention: Final standpipe assembly, the nut will be tightened at least by 1/4 of a turn beyond the point of a noticeable increase in force.

Atención: El montaje del vástago premontado se completa girando 1/4 vuelta la tuerca de unión a partir del punto en que aumenta claramente la resistencia.

**Einstellbare Winkelverschraubungen mit Schaft**  
**Adjustable standpipe elbow fittings**  
**Racores angulares ajustables con vástago**

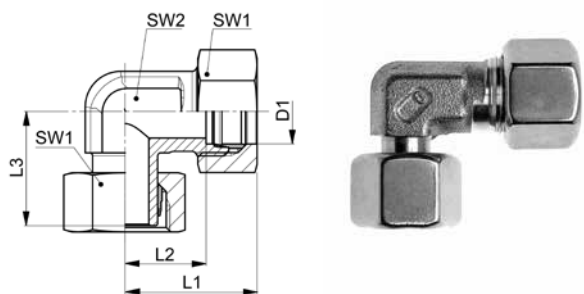

10

**EWV-..L/S**

Type -D1	Mat.-Nr.	PN	L1	L2	L3	SW1	SW2	g/Stk
EWV-06L	708.2620.060.20	500	27.0	12.0	26.0	14	12	35
EWV-08L	708.2620.080.20	500	29.0	14.0	27.5	17	12	54
EWV-10L	708.2620.100.20	500	30.0	15.0	29.0	19	14	68
EWV-12L	708.2620.120.20	400	32.0	17.0	29.5	22	17	95
EWV-15L	708.2620.150.20	400	36.0	21.0	32.5	27	19	170
EWV-18L	708.2620.180.20	400	40.0	23.5	35.5	32	24	250
EWV-22L	708.2620.220.20	250	44.0	27.5	38.5	36	27	335
EWV-28L	708.2620.280.20	250	47.0	30.5	41.5	41	36	475
EWV-35L	708.2620.350.20	250	56.0	34.5	51.0	50	41	700
EWV-42L	708.2620.420.20	250	63.0	40.0	56.0	60	50	1071
EWV-06S	708.2620.060.30	800	31.0	16.0	27.0	17	12	62
EWV-08S	708.2620.080.30	800	32.0	17.0	27.5	19	14	90
EWV-10S	708.2620.100.30	800	34.0	17.5	30.0	22	17	123
EWV-12S	708.2620.120.30	630	38.0	21.5	31.0	24	17	140
EWV-14S	708.2620.140.30	630	40.0	22.0	35.0	27	19	200
EWV-16S	708.2620.160.30	630	43.0	24.5	36.5	30	24	248
EWV-20S	708.2620.200.30	420	48.0	26.5	44.5	36	27	432
EWV-25S	708.2620.250.30	420	54.0	30.0	50.0	46	36	784
EWV-30S	708.2620.300.30	420	62.0	35.5	55.0	50	41	996
EWV-38S	708.2620.380.30	420	72.0	41.0	63.0	60	50	1530

Baumaße sind Ungefährmaße bei angezogener Überwurfmutter.

Sizes are approximate dimensions at tightened nut.

Las medidas son aproximadas con la tuerca de unión apretada.

Achtung: Endmontage des vormontierten Schaftes wird erst nach 1/4 Umdrehung der Überwurfmutter über den Punkt des deutlich fühlbaren Kraftanstiegs erreicht.

Attention: Final standpipe assembly, the nut will be tightened at least by 1/4 of a turn beyond the point of a noticeable increase in force.

Atención: El montaje del vástago premontado se completa girando 1/4 vuelta la tuerca de unión a partir del punto en que aumenta claramente la resistencia.

## Einstellbare Winkel-Einschraubverschraubungen mit Schaft

mit Einschraubstutzen, Abdichtung durch Dichtkante Form B nach DIN 3852-2

## Adjustable male adaptor standpipe elbow fittings

with male adaptor connector, sealing edge form B acc. DIN 3852-2

## Racores angulares para roscar ajustables con vástago

con racor para roscar, cierre hermético mediante borde de obturación forma B según DIN 3852-2

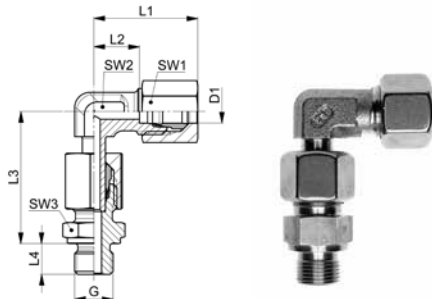

### EWV-..LR/SR

Type-D1 G	Mat.-Nr.	PN	G	L1	L2	L3	L4	SW1	SW2	SW3	g/Stk
G=Rohrgewinde (zylindrisch)		G=BSP thread (parallel)				G=rosca de conexión (cilíndrica)					
EWV-06LR 1.8	708.2621.100.20	500	1/8	27.0	12.0	34.5	8.0	14	12	14	57
EWV-08LR 1.4	708.2621.170.20	500	1/4	29.0	14.0	37.5	12.0	17	12	19	82
EWV-10LR 1.4	708.2621.270.20	500	1/4	30.0	15.0	40.0	12.0	19	14	19	96
EWV-12LR 1.4	708.2621.380.20	400	1/4	32.0	17.0	41.5	12.0	22	17	19	126
EWV-12LR 3.8	708.2621.390.20	400	3/8	32.0	17.0	42.0	12.0	22	17	22	134
EWV-12LR 1.2	708.2621.400.20	400	1/2	32.0	17.0	42.5	14.0	22	17	27	164
EWV-15LR 1.2	708.2621.534.20	400	1/2	36.0	21.0	46.5	14.0	27	19	27	229
EWV-18LR 1.2	708.2621.646.20	400	1/2	40.0	23.5	50.0	14.0	32	24	27	305
EWV-22LR 3.4	708.2621.768.20	250	3/4	44.0	27.5	55.0	16.0	36	27	32	415
EWV-28LR 1.1	708.2621.850.20	250	1	47.0	30.5	59.0	18.0	41	36	41	614
EWV-35LR 5.4	708.2621.944.20	250	1 1/4	56.0	34.5	68.5	20.0	50	41	50	984
EWV-42LR 3.2	708.2621.992.20	250	1 1/2	63.0	40.0	75.0	22.0	60	50	55	1417
EWV-06SR 1.4	708.2621.110.30	800	1/4	31.0	16.0	40.0	12.0	17	12	19	99
EWV-08SR 1.4	708.2621.170.30	800	1/4	32.0	17.0	42.5	12.0	19	14	19	121
EWV-10SR 3.8	708.2621.280.30	800	3/8	34.0	17.5	42.5	12.0	22	17	22	169
EWV-12SR 3.8	708.2621.390.30	630	3/8	38.0	21.5	48.5	12.0	24	17	22	222
EWV-12SR 1.2	708.2621.400.30	630	1/2	38.0	21.5	49.0	14.0	24	17	27	234
EWV-14SR 1.2	708.2621.504.30	630	1/2	40.0	22.0	49.0	14.0	27	19	27	287
EWV-16SR 1.2	708.2621.566.30	630	1/2	43.0	24.5	54.5	14.0	30	24	27	339
EWV-20SR 3.4	708.2621.708.30	420	3/4	48.0	26.5	65.0	16.0	36	27	32	551
EWV-25SR 1.1	708.2621.810.30	420	1	54.0	30.0	70.0	16.0	46	36	32	1054
EWV-30SR 5.4	708.2621.902.30	420	1 1/4	62.0	35.5	78.5	20.0	50	41	50	1398
EWV-38SR 3.2	708.2621.953.30	420	1 1/2	72.0	41.0	82.5	22.0	60	50	55	1987

Baumaße sind Ungefährmaße bei angezogener Überwurfmutter.

Sizes are approximate dimensions at tightened nut.

Las medidas son aproximadas con la tuerca de unión apretada.

Achtung: Endmontage des vormontierten Schaftes wird erst nach 1/4 Umdrehung der Überwurfmutter über den Punkt des deutlich fühlbaren Kraftanstiegs erreicht.

Attention: Final standpipe assembly, the nut will be tightened at least by 1/4 of a turn beyond the point of a noticeable increase in force.

Atención: El montaje del vástago premontado se completa girando 1/4 vuelta la tuerca de unión a partir del punto en que aumenta claramente la resistencia.

**Einstellbare Verschraubungen**

**Adjustable fittings**

**Racores ajustables**

**Einstellbare Winkel-Einschraubverschraubungen**

Für eine einstellbare Winkel-Einschraubverschraubung kombinieren wir die einstellbare Winkelverschraubung mit Schaft EWV...L/S bzw. die einstellbare Winkelverschraubung mit Dichtkegel EWKO...L/S mit einem geraden Einschraubstutzen.

EWV...L/S + XGEV...LR/SR = EWV...LR/SR  
EWKO...L/S + XGEV...LR/SR = EWKO...LR/SR

Weitere Kombinationen sind möglich:

**Adjustable male adaptor elbow fittings**

For an adjustable male adaptor elbow fitting we combine the adjustable standpipe elbow fitting EWV...L/S or the adjustable elbow fitting with taper EWKO...L/S with a straight male adaptor union.

EWV...L/S + XGEV...LR/SR = EWV...LR/SR  
EWKO...L/S + XGEV...LR/SR = EWKO...LR/SR

Other combinations are possible:

**Racores para roscar angulares ajustables**

Para obtener un racor para roscar angular ajustable combinamos el racor angular ajustable con vástago EWV...L/S o el racor angular ajustable con junta cónica EWKO...L/S con un racor para roscar recto.

EWV...L/S + XGEV...LR/SR = EWV...LR/SR  
EWKO...L/S + XGEV...LR/SR = EWKO...LR/SR

Son posibles otras combinaciones:

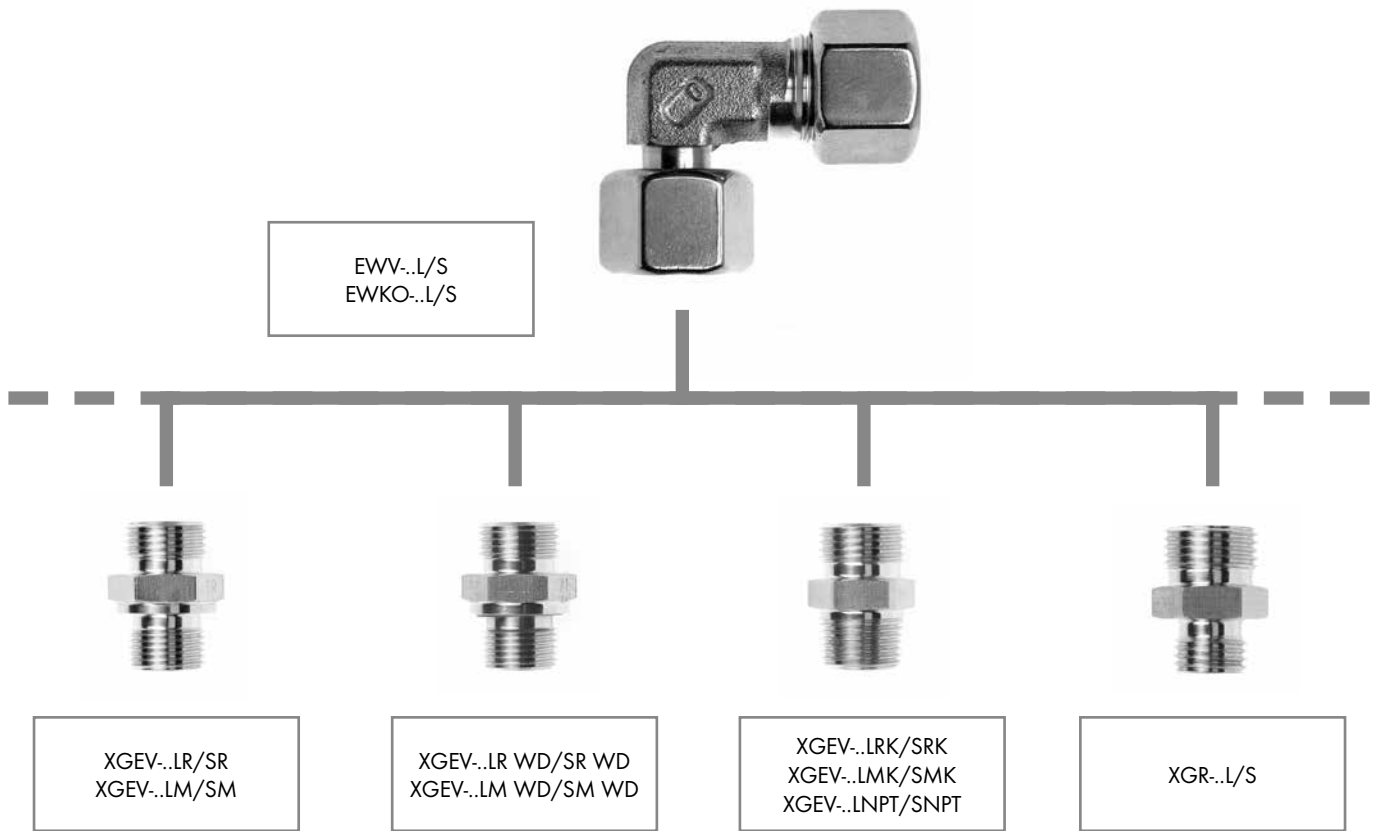

Kombination mit

- XGEV...LR/SR, XGEV...LM/SM für zylindrische Einschraubgewinde (zöllig bzw. metrisch) mit Abdichtung durch Dichtkante Form B nach DIN 3852-2
- XGEV...LR WD/SR WD, XGEV...LM WD/SM WD für zylindrische Einschraubgewinde (zöllig bzw. metrisch) mit Abdichtung durch Profildichtring Form E nach DIN 3852-11
- XGEV...LRK/SRK, XGEV...LMK/SMK, XGEV...LNPT/SNPT für konische Einschraubgewinde (zöllig bzw. metrisch) mit Abdichtung im Kegelfgewinde Form C nach DIN 3852-2
- XGR...L/S für den Übergang auf andere Anschlussgrößen

Combination with

- XGEV...LR/SR, XGEV...LM/SM for parallel male adaptor threads (English or metric) with sealing through seal edge form B acc. to DIN 3852-2
- XGEV...LR WD/SR WD, XGEV...LM WD/SM WD for parallel male adaptor threads (English or metric) with sealing through profile seal ring form E acc. to DIN 3852-11
- XGEV...LRK/SRK, XGEV...LMK/SMK, XGEV...LNPT/SNPT for tapered male adaptor threads (English or metric) with taper thread sealing form C acc. to DIN 3852-2
- XGR...L/S for transitioning to other connection sizes

Combinación con

- XGEV...LR/SR, XGEV...LM/SM para rosca de conexión cilíndrica (inglesa o métrica) con cierre hermético mediante junta de obturación según DIN 3852-2
- XGEV...LR WD/SR WD, XGEV...LM WD/SM WD para rosca de conexión cilíndrica (inglesa o métrica) con cierre hermético mediante junta anular de perfil, forma E según DIN 3852-11
- XGEV...LRK/SRK, XGEV...LMK/SMK, XGEV...LNPT/SNPT para rosca de conexión cónica (inglesa o métrica) con cierre hermético mediante rosca cónica, forma C según DIN 3852-2
- XGR...L/S para la transición a otros tamaños de conexión

## Einstellbare Winkel-Einschraubstutzen

mit Kontermutter, Abdichtung durch gekammerten O-Ring, ISO 1179-3

## Adjustable male adaptor elbow connectors

with counter nut, sealing with restraining O-ring, ISO 1179-3

## Cuerpos para roscar en codo ajustables

con contratuerca, cierre hermético mediante junta tórica protegida, ISO 1179-3

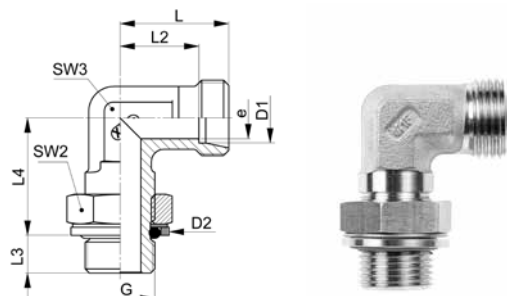

### XWEE-..LR

Type-D1 G	Mat.-Nr.	PN	G	D2	L	L2	L3	L4	SW2	SW3	e	g/Stk
G=Rohrgewinde (zylindrisch)		G=BSP thread (parallel)					G=rosca de conexión (cilíndrica)					
XWEE-06LR 1.8	707.2407.100.20	200	1/8	15.0	21.0	14.0	7.0	19.0	14	12	4.0	29
XWEE-08LR 1.4	707.2407.170.20	200	1/4	19.5	23.0	16.0	9.0	23.0	19	12	4.0	46
XWEE-10LR 1.4	707.2407.270.20	200	1/4	19.5	24.0	17.0	9.0	25.0	19	14	8.0	56
XWEE-12LR 3.8	707.2407.390.20	200	3/8	23.5	26.0	19.0	9.0	28.0	22	17	10.0	77
XWEE-15LR 1.2	707.2407.534.20	200	1/2	28.5	28.0	21.0	13.0	30.0	27	19	12.0	133
XWEE-18LR 1.2	707.2407.646.20	200	1/2	28.5	31.0	24.0	13.0	36.0	27	24	15.0	177
XWEE-22LR 3.4	707.2407.768.20	200	3/4	34.5	35.0	28.0	13.0	36.0	36	27	19.0	266
XWEE-28LR 1.1	707.2407.850.20	200	1	43.5	38.0	31.0	15.0	44.0	41	36	24.0	443
XWEE-35LR 5.4	707.2407.944.20	160	1 1/4	52.5	45.0	34.0	15.0	50.0	55	41	27.5	640
XWEE-42LR 3.2	707.2407.992.20	160	1 1/2	60.0	49.0	38.0	15.0	52.5	55	50	33.0	988

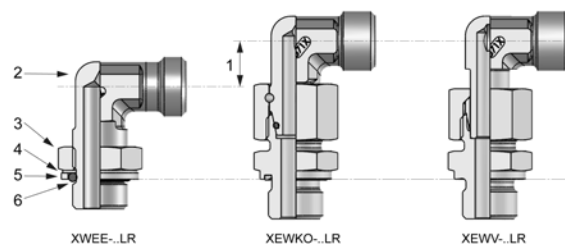

- 1 - Höhenunterschied
- 2 - Einschraubwinkel, 1.4571 / AISI 316 Ti
- 3 - Kontermutter, 1.4571 / AISI 316 Ti
- 4 - Konterscheibe, 1.4301 / AISI 304
- 5 - Kammerring, 1.4571 / AISI 316 Ti
- 6 - O-Ring, FKM

- 1 - Difference in height
- 2 - Male adaptor elbow, 1.4571 / AISI 316 Ti
- 3 - Counter nut, 1.4571 / AISI 316 Ti
- 4 - Locking washer, 1.4301 / AISI 304
- 5 - Restraining ring, 1.4571 / AISI 316 Ti
- 6 - O-ring, FKM

- 1 - Diferencia de altura
- 2 - Junta roscada en ángulo, 1.4571 / AISI 316 Ti
- 3 - Contratuerca, 1.4571 / AISI 316 Ti
- 4 - Arandela de sujeción, 1.4301 / AISI 304
- 5 - Anillo retentivo, 1.4571 / AISI 316 Ti
- 6 - O-ring, FKM

## Einstellbare Winkel-Einschraubverschraubungen

mit Kontermutter, Abdichtung durch gekammerten O-Ring, ISO 1179-3

## Adjustable male adaptor elbow fittings

with counter nut, sealing with restraining O-ring, ISO 1179-3

## Racores para roscar en codo ajustables

con contratueras, cierre hermético mediante junta tórica protegida, ISO 1179-3

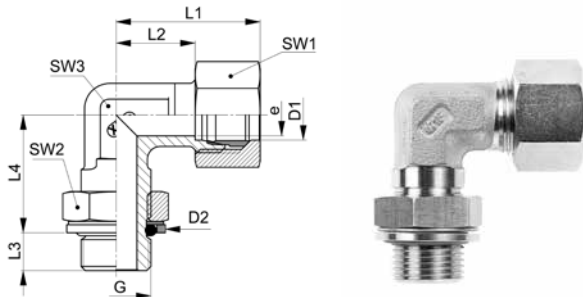

10

### WEE-..LR

Type-D1 G	Mat.-Nr.	PN	G	D2	L1	L2	L3	L4	SW1	SW2	SW3	g/Stk
G=Rohrgewinde (zylindrisch)		G=BSP thread (parallel)										
												G=rosca de conexión (cilíndrica)
WEE-06LR 1.8	708.2407.100.20	200	1/8	15.0	29.0	14.0	7.0	19.0	14	14	12	40
WEE-08LR 1.4	708.2407.170.20	200	1/4	19.5	31.0	16.0	9.0	23.0	17	19	12	63
WEE-10LR 1.4	708.2407.270.20	200	1/4	19.5	32.0	17.0	9.0	25.0	19	19	14	77
WEE-12LR 3.8	708.2407.390.20	200	3/8	23.5	34.0	19.0	9.0	28.0	22	22	17	106
WEE-15LR 1.2	708.2407.534.20	200	1/2	28.5	36.0	21.0	13.0	30.0	27	27	19	179
WEE-18LR 1.2	708.2407.646.20	200	1/2	28.5	40.0	24.0	13.0	36.0	32	27	24	246
WEE-22LR 3.4	708.2407.768.20	200	3/4	34.5	44.0	28.0	13.0	36.0	36	36	22	356
WEE-28LR 1.1	708.2407.850.20	200	1	43.5	47.0	31.0	15.0	44.0	41	41	36	550
WEE-35LR 5.4	708.2407.944.20	160	1 1/4	52.5	56.0	34.0	15.0	40.0	50	55	41	820
WEE-42LR 3.2	708.2407.992.20	160	1 1/2	60.0	61.0	38.0	15.0	52.5	60	55	50	1231

Baumaße sind Ungefährmaße bei angezogener Überwurfmutter.

Sizes are approximate dimensions at tightened nut.

Las medidas son aproximadas con la tuerca de unión apretada.

Dichtungsmaterial: FKM

Sealing material: FKM

Material de junta tórica: FKM.

Konterscheibe aus Edelstahl 1.4301 / AISI 304

Locking washer made of stainless steel 1.4301 / AISI 304

Arandela de sujeción hecho de acero inoxidable 1.4301 / AISI 304

### Montageanleitung

### Installation instruction

### Instrucción de montaje

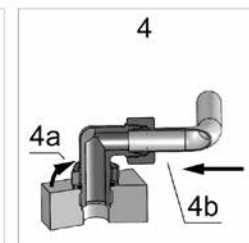
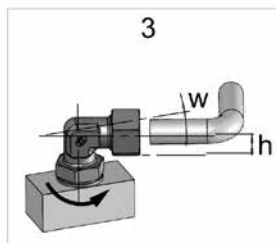
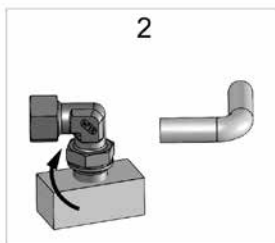
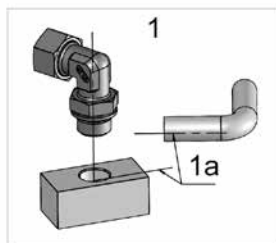

- 1 - Ausgangslage  
1a: abweichende Winkel
- 2 - Verschraubung bis zum Anschlag einschrauben
- 3 - Verschraubung ausrichten  
Höhe (h) +/- Gewindesteigung  
Winkel (w)
- 4 - Fertigmontage  
4a: Kontermutter anziehen  
4b: Rohr montieren

- 1 - Starting position  
1a: different angles
- 2 - Screw fitting until it stops
- 3 - Align fitting  
height (h) +/- thread pitch angle (w)
- 4 - Final assembly  
4a: Tighten counter nut  
4b: Install tube

- 1 - Situación inicial  
1a: ángulos diferentes
- 2 - Enroscar el racor hasta que se detenga
- 3 - Alinear el racor  
altura (h) +/- paso de rosca ángulo (w)
- 4 - Montaje final  
4a: Apriete contratuerca  
4b: Instalar tubo

**Einstellbare T-Stutzen mit Dichtkegel und O-Ring**

dichtkegelseitig vormontiert

**Adjustable T connectors with taper and O-ring**

pre-assembled on tapered nipple side

**Cuerpos T ajustables con junta cónica y junta tórica**

premontado en lado de junta cónica

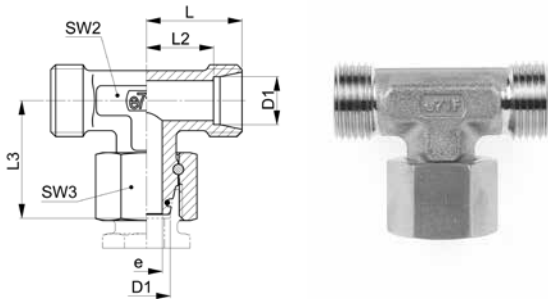

**XETKO-..L/S M**

Type-D1	Mat.-Nr.	PN	L	L2	L3	SW2	SW3	e	g/Stk
XETKO-06L M	707.3670.060.20	315	19.0	12.0	26.0	12	14	3.0	44
XETKO-08L M	707.3670.080.20	315	21.0	14.0	27.5	12	17	4.0	57
XETKO-10L M	707.3670.100.20	315	22.0	15.0	29.0	14	19	6.0	72
XETKO-12L M	707.3670.120.20	315	24.0	17.0	29.5	17	22	8.0	94
XETKO-15L M	707.3670.150.20	315	28.0	21.0	32.5	19	27	10.0	163
XETKO-18L M	707.3670.180.20	315	31.0	23.5	35.5	24	32	13.0	218
XETKO-22L M	707.3670.220.20	160	35.0	27.5	38.5	27	36	17.0	306
XETKO-28L M	707.3670.280.20	160	38.0	30.5	41.5	36	41	22.0	461
XETKO-35L M	707.3670.350.20	160	45.0	34.5	51.0	41	50	28.0	691
XETKO-42L M	707.3670.420.20	160	51.0	40.0	56.0	50	60	34.0	1052
XETKO-06S M	707.3670.060.30	630	23.0	16.0	27.0	12	17	3.0	67
XETKO-08S M	707.3670.080.30	630	24.0	17.0	27.5	14	19	4.0	88
XETKO-10S M	707.3670.100.30	630	25.0	17.5	30.0	17	22	6.0	115
XETKO-12S M	707.3670.120.30	630	29.0	21.5	31.0	17	24	8.0	147
XETKO-14S M	707.3670.140.30	630	30.0	22.0	35.0	19	27	9.0	190
XETKO-16S M	707.3670.160.30	400	33.0	24.5	36.5	24	30	11.0	244
XETKO-20S M	707.3670.200.30	400	37.0	26.5	44.5	27	36	14.0	383
XETKO-25S M	707.3670.250.30	400	42.0	30.0	50.0	36	46	18.0	685
XETKO-30S M	707.3670.300.30	400	49.0	35.5	55.0	41	50	23.0	916
XETKO-38S M	707.3670.380.30	315	57.0	41.0	63.0	50	60	30.0	1383

Dichtungsmaterial: FKM

Sealing material: FKM

Material de junta tórica: FKM

**ISO 8434-1-SWOBT**

**Einstellbare T-Verschraubungen mit Dichtkegel und O-Ring**  
**Adjustable T fittings with taper and O-ring**  
**Racores T ajustables con junta cónica y junta tórica**

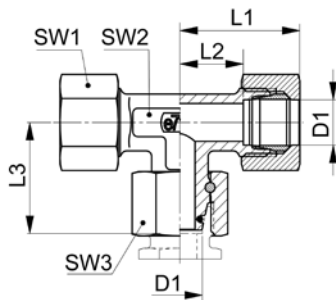

10

**ETKO-..L/S**

Type -D1	Mat.-Nr.	PN	L1	L2	L3	SW1	SW2	SW3	g/Stk
ETKO-06L	708.3670.060.20	315	27.0	12.0	26.0	14	12	14	54
ETKO-08L	708.3670.080.20	315	29.0	14.0	27.5	17	12	17	76
ETKO-10L	708.3670.100.20	315	30.5	15.0	29.0	19	14	19	107
ETKO-12L	708.3670.120.20	315	32.5	17.0	29.5	22	17	22	135
ETKO-15L	708.3670.150.20	315	37.0	21.0	32.5	27	19	27	223
ETKO-18L	708.3670.180.20	315	40.5	23.5	35.5	32	24	32	332
ETKO-22L	708.3670.220.20	160	44.5	27.5	38.5	36	27	36	439
ETKO-28L	708.3670.280.20	160	47.5	30.5	41.5	41	36	41	659
ETKO-35L	708.3670.350.20	160	57.0	34.5	51.0	50	41	50	915
ETKO-42L	708.3670.420.20	160	63.5	40.0	56.0	60	50	60	1536
ETKO-06S	708.3670.060.30	630	31.0	16.0	27.0	17	12	17	87
ETKO-08S	708.3670.080.30	630	32.0	17.0	27.5	19	14	19	109
ETKO-10S	708.3670.100.30	630	34.5	17.5	30.0	22	17	22	169
ETKO-12S	708.3670.120.30	630	38.5	21.5	31.0	24	17	24	212
ETKO-14S	708.3670.140.30	630	40.5	22.0	35.0	27	19	27	281
ETKO-16S	708.3670.160.30	400	44.0	24.5	36.5	30	24	30	382
ETKO-20S	708.3670.200.30	400	49.5	26.5	44.5	36	27	36	542
ETKO-25S	708.3670.250.30	400	55.5	30.0	50.0	46	36	46	1050
ETKO-30S	708.3670.300.30	400	63.5	35.5	55.0	50	41	50	1349
ETKO-38S	708.3670.380.30	315	74.0	41.0	63.0	60	50	60	2061

Baumaße sind Ungefährmaße bei angezogener Überwurfmutter.

Sizes are approximate dimensions at tightened nut.

Las medidas son aproximadas con la tuerca de unión apretada.

Dichtungsmaterial: FKM

Sealing material: FKM

Material de junta tórica: FKM.

**ISO 8434-1-SWOBTC**

**Einstellbare T-Stutzen mit Schaft**

schaftseitig vormontiert

**Adjustable standpipe T connectors**

pre-assembled on standpipe side

**Cuerpos T ajustables con vástago**

premontado en lado de vástago

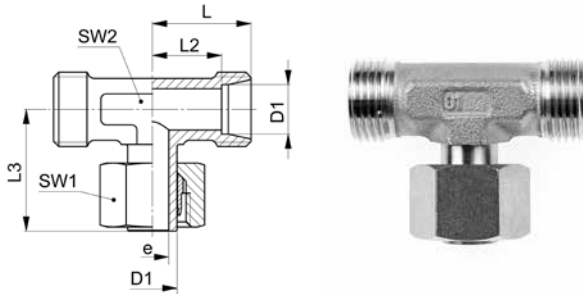

**XETV-..L/S M**

Type-D1	Mat.-Nr.	PN	L	L2	L3	SW1	SW2	e	g/Stk
XETV-06L M	707.3620.060.20	500	19.0	12.0	26.0	14	12	3.0	39
XETV-08L M	707.3620.080.20	500	21.0	14.0	27.5	17	12	5.0	50
XETV-10L M	707.3620.100.20	500	22.0	15.0	29.0	19	14	6.5	68
XETV-12L M	707.3620.120.20	400	24.0	17.0	29.5	22	17	8.0	87
XETV-15L M	707.3620.150.20	400	28.0	21.0	32.5	27	19	10.0	152
XETV-18L M	707.3620.180.20	400	31.0	23.5	35.5	32	24	13.0	213
XETV-22L M	707.3620.220.20	250	35.0	27.5	38.5	36	27	16.0	306
XETV-28L M	707.3620.280.20	250	38.0	30.5	41.5	41	36	22.0	455
XETV-35L M	707.3620.350.20	250	45.0	34.5	51.0	50	41	28.0	679
XETV-42L M	707.3620.420.20	250	51.0	40.0	56.0	60	50	34.0	1032
XETV-06S M	707.3620.060.30	800	23.0	16.0	27.0	17	12	3.0	62
XETV-08S M	707.3620.080.30	800	24.0	17.0	27.5	19	14	4.0	80
XETV-10S M	707.3620.100.30	800	25.0	17.5	30.0	22	17	6.0	109
XETV-12S M	707.3620.120.30	630	29.0	21.5	31.0	24	17	7.0	142
XETV-14S M	707.3620.140.30	630	30.0	22.0	35.0	27	19	9.0	184
XETV-16S M	707.3620.160.30	630	33.0	24.5	36.5	30	24	10.5	241
XETV-20S M	707.3620.200.30	420	37.0	26.5	44.5	36	27	14.0	376
XETV-25S M	707.3620.250.30	420	42.0	30.0	50.0	46	36	17.0	699
XETV-30S M	707.3620.300.30	420	49.0	35.5	55.0	50	41	22.0	937
XETV-38S M	707.3620.380.30	420	57.0	41.0	63.0	60	50	27.0	1005

Achtung: Endmontage des vormontierten Schaftes wird erst nach 1/4 Umdrehung der Überwurfmutter über den Punkt des deutlich fühlbaren Kraftanstiegs erreicht.

Attention: Final standpipe assembly, the nut will be tightened at least by 1/4 of a turn beyond the point of a noticeable increase in force.

Atención: El montaje del vástago premontado se completa girando 1/4 vuelta la tuerca de unión a partir del punto en que aumenta claramente la resistencia.

**Einstellbare T-Verschraubungen mit Schaft**  
**Adjustable standpipe T fittings**  
**Racores T ajustables con vástago**

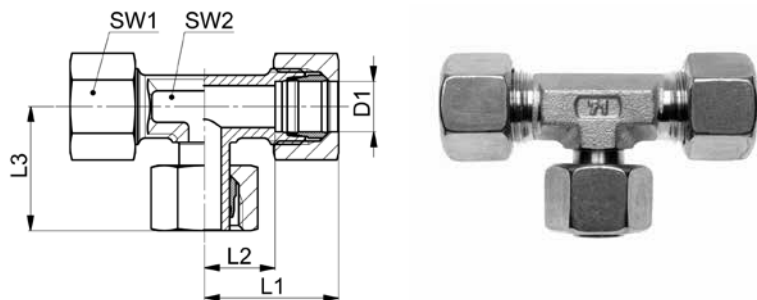

10

**ETV-..L/S**

Type -D1	Mat.-Nr.	PN	L1	L2	L3	SW1	SW2	g/Stk
ETV-06L	708.3620.060.20	500	27.0	12.0	26.0	14	12	62
ETV-08L	708.3620.080.20	500	29.0	14.0	27.5	17	12	84
ETV-10L	708.3620.100.20	500	30.0	15.0	29.0	19	14	110
ETV-12L	708.3620.120.20	400	32.0	17.0	29.5	22	17	145
ETV-15L	708.3620.150.20	400	36.0	21.0	32.5	27	19	246
ETV-18L	708.3620.180.20	400	40.0	23.5	35.5	32	24	351
ETV-22L	708.3620.220.20	250	44.0	27.5	38.5	36	27	486
ETV-28L	708.3620.280.20	250	47.0	30.5	41.5	41	36	667
ETV-35L	708.3620.350.20	250	56.0	34.5	51.0	50	41	1005
ETV-42L	708.3620.420.20	250	63.0	40.0	56.0	60	50	1539
ETV-06S	708.3620.060.30	800	31.0	16.0	27.0	17	12	100
ETV-08S	708.3620.080.30	800	32.0	17.0	27.5	19	14	125
ETV-10S	708.3620.100.30	800	34.0	17.5	30.0	22	17	176
ETV-12S	708.3620.120.30	630	38.0	21.5	31.0	24	17	217
ETV-14S	708.3620.140.30	630	40.0	22.0	35.0	27	19	298
ETV-16S	708.3620.160.30	630	43.0	24.5	36.5	30	24	382
ETV-20S	708.3620.200.30	420	48.0	26.5	44.5	36	27	602
ETV-25S	708.3620.250.30	420	54.0	30.0	50.0	46	36	1149
ETV-30S	708.3620.300.30	420	62.0	35.5	55.0	50	41	1433
ETV-38S	708.3620.380.30	420	72.0	41.0	63.0	60	50	2187

Baumaße sind Ungefährmaße bei angezogener Überwurfmutter.

Sizes are approximate dimensions at tightened nut.

Las medidas son aproximadas con la tuerca de unión apretada.

Achtung: Endmontage des vormontierten Schaftes wird erst nach 1/4 Umdrehung der Überwurfmutter über den Punkt des deutlich fühlbaren Kraftanstiegs erreicht.

Attention: Final standpipe assembly, the nut will be tightened at least by 1/4 of a turn beyond the point of a noticeable increase in force.

Atención: El montaje del vástago premontado se completa girando 1/4 vuelta la tuerca de unión a partir del punto en que aumenta claramente la resistencia.

**Einstellbare T-Einschraubverschraubungen mit Schaft**

mit Einschraubstutzen, Abdichtung durch Dichtkante Form B nach DIN 3852-2

**Adjustable male adaptor standpipe T fittings**

with male adaptor connector, sealing edge form B acc. DIN 3852-2

**Racores T para roscar ajustables con vástago**

con racor para roscar, cierre hermético mediante borde de obturación forma B según DIN 3852-2

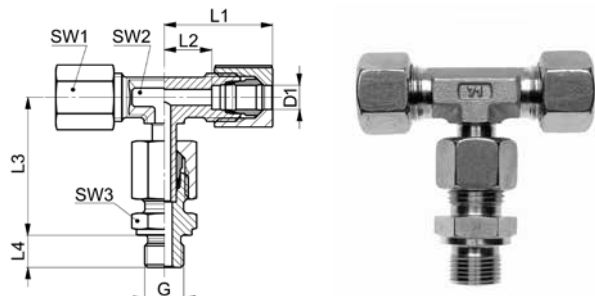

**ETV-..LR/SR**

Type-D1 G	Mat.-Nr.	PN	G	L1	L2	L3	L4	SW1	SW2	SW3	g/Stk
G=Rohrgewinde (zylindrisch)		G=BSP thread (parallel)			G=rosca de conexión (cilíndrica)						
ETV-06LR 1.8	708.3651.100.20	500	1/8	27.0	12.0	34.5	10.0	14	12	14	71
ETV-08LR 1.4	708.3651.170.20	500	1/4	29.0	14.0	37.5	10.0	17	12	17	106
ETV-10LR 1.4	708.3651.270.20	500	1/4	30.0	14.0	40.0	11.0	19	14	19	128
ETV-12LR 3.8	708.3651.390.20	400	3/8	32.0	17.0	42.0	11.0	22	17	22	175
ETV-15LR 1.2	708.3651.534.20	400	1/2	36.0	21.0	46.5	12.0	27	19	24	291
ETV-18LR 1.2	708.3651.646.20	400	1/2	40.0	23.5	50.0	12.0	32	24	24	427
ETV-22LR 3.4	708.3651.768.20	250	3/4	44.0	27.5	55.0	14.0	36	27	32	568
ETV-28LR 1.1	708.3651.850.20	250	1	47.0	30.5	59.0	14.0	41	36	41	792
ETV-35LR 5.4	708.3651.944.20	250	1 1/4	56.0	34.5	68.5	16.0	50	41	50	1230
ETV-42LR 3.2	708.3651.992.20	250	1 1/2	63.0	40.0	75.0	16.0	60	50	55	1671
ETV-06SR 1.4	708.3651.110.30	800	1/4	31.0	16.0	40.0	12.0	17	12	17	128
ETV-08SR 1.4	708.3651.170.30	800	1/4	32.0	17.0	42.5	12.0	19	14	19	158
ETV-10SR 3.8	708.3651.280.30	800	3/8	34.0	17.5	45.0	12.0	22	17	22	219
ETV-12SR 3.8	708.3651.390.30	630	3/8	38.0	21.5	48.0	12.0	24	17	24	277
ETV-14SR 1.2	708.3651.504.30	630	1/2	40.0	22.0	54.0	14.0	27	19	27	387
ETV-16SR 1.2	708.3651.566.30	630	1/2	43.0	24.5	55.0	14.0	30	24	27	442
ETV-20SR 3.4	708.3651.704.30	420	3/4	48.0	26.5	67.0	16.0	36	27	32	722
ETV-25SR 1.1	708.3651.810.30	420	1	54.0	30.0	73.0	18.0	46	36	41	1428
ETV-30SR 3.2	708.3651.905.30	420	1 1/2	62.0	35.5	81.5	20.0	50	41	50	1731
ETV-38SR 5.4	708.3651.954.30	420	1 1/4	72.0	41.0	89.0	22.0	60	50	55	2624

Baumaße sind Ungefährmaße bei angezogener Überwurfmutter.

Sizes are approximate dimensions at tightened nut.

Las medidas son aproximadas con la tuerca de unión apretada.

Achtung: Endmontage des vormontierten Schaftes wird erst nach 1/4 Umdrehung der Überwurfmutter über den Punkt des deutlich fühlbaren Kraftanstiegs erreicht.

Attention: Final standpipe assembly, the nut will be tightened at least by 1/4 of a turn beyond the point of a noticeable increase in force.

Atención: El montaje del vástago premontado se completa girando 1/4 vuelta la tuerca de unión a partir del punto en que aumenta claramente la resistencia.

**Einstellbare T-Einschraubverschraubung**

Für eine einstellbare T-Einschraubverschraubung kombinieren wir die einstellbare T-Verschraubung mit Schaft ETV...L/S bzw. die einstellbare T-Verschraubung mit Dichtkegel ETKO...L/S mit einem geraden Einschraubstutzen.

ETKO...L/S + XGEV...LR/SR = ETKO...LR/SR  
ETV...L/S + XGEV...LR/SR = ETV...LR/SR

Weitere Kombinationen sind möglich:

**Adjustable male adaptor T fittings**

For an adjustable male adaptor T fitting we combine the adjustable standpipe T fitting ETV...L/S or the adjustable T fitting with taper ETKO...L/S with a straight male adaptor union.

ETKO...L/S + XGEV...LR/SR = ETKO...LR/SR  
ETV...L/S + XGEV...LR/SR = ETV...LR/SR

Other combinations are possible:

**Racores para roscar T ajustables**

Para obtener un racor para roscar T ajustable combinamos el racor T ajustable con vástago ETV...L/S o el racor T ajustable con junta cónica ETKO...L/S con un racor para roscar recto.

ETKO...L/S + XGEV...LR/SR = ETKO...LR/SR  
ETV...L/S + XGEV...LR/SR = ETV...LR/SR

Son posibles otras combinaciones:

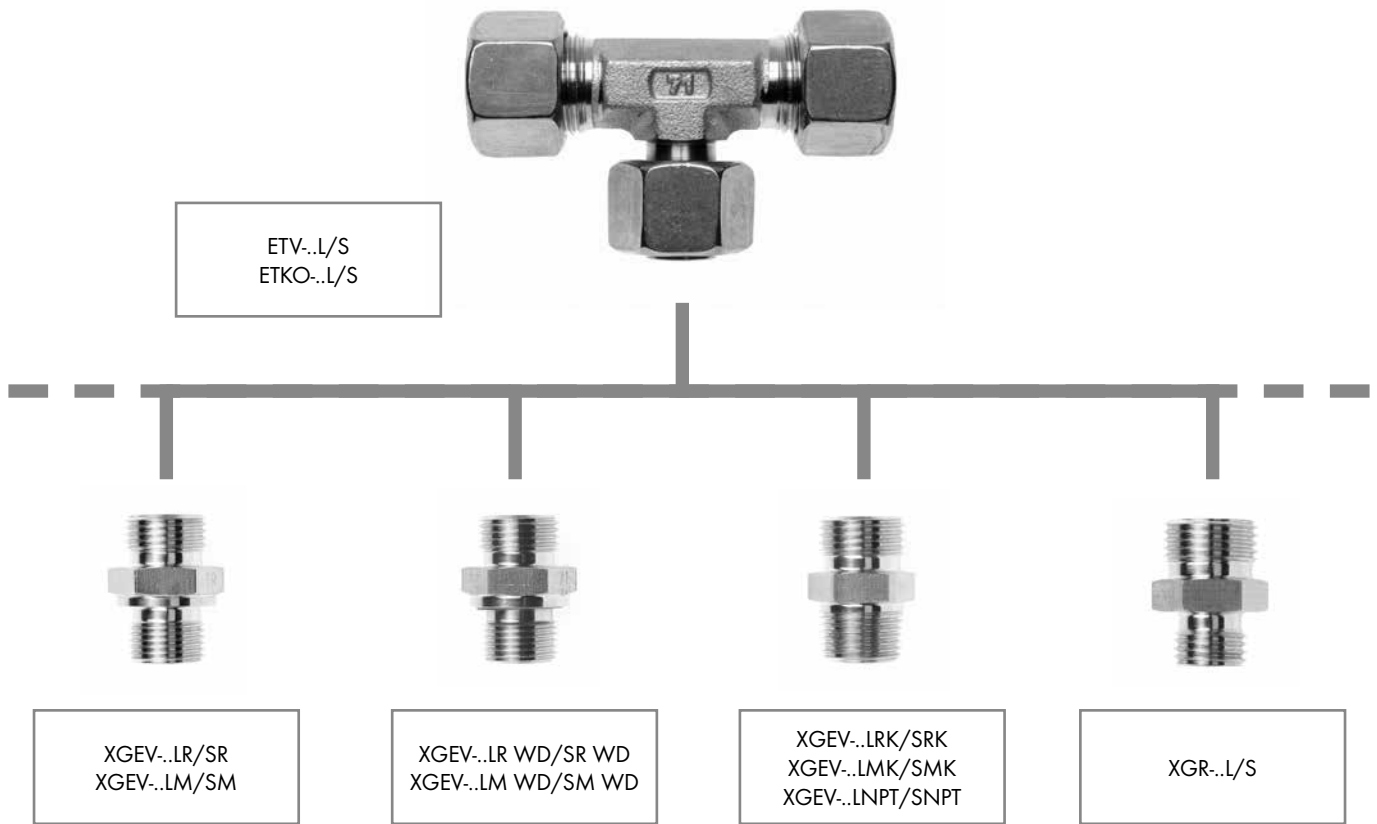

Kombination mit

- XGEV...LR/SR, XGEV...LM/SM für zylindrische Einschraubgewinde (zöllig bzw. metrisch) mit Abdichtung durch Dichtkante Form B nach DIN 3852-2
- XGEV...LR WD/SR WD, XGEV...LM WD/SM WD für zylindrische Einschraubgewinde (zöllig bzw. metrisch) mit Abdichtung durch Profildichtring Form E nach DIN 3852-11
- XGEV...LRK/SRK, XGEV...LMK/SMK, XGEV...LNPT/SNPT für konische Einschraubgewinde (zöllig bzw. metrisch) mit Abdichtung im Kegelfgewinde Form C nach DIN 3852-2
- XGR...L/S für den Übergang auf andere Anschlussgrößen

Combination with

- XGEV...LR/SR, XGEV...LM/SM for parallel male adaptor threads (English or metric) with sealing through seal edge form B acc. to DIN 3852-2
- XGEV...LR WD/SR WD, XGEV...LM WD/SM WD for parallel male adaptor threads (English or metric) with sealing through profile seal ring form E acc. to DIN 3852-11
- XGEV...LRK/SRK, XGEV...LMK/SMK, XGEV...LNPT/SNPT for tapered male adaptor threads (English or metric) with taper thread sealing form C acc. to DIN 3852-2
- XGR...L/S for transitioning to other connection sizes

Combinación con

- XGEV...LR/SR, XGEV...LM/SM para rosca de conexión cilíndrica (inglesa o métrica) con cierre hermético mediante junta de obturación según DIN 3852-2
- XGEV...LR WD/SR WD, XGEV...LM WD/SM WD para rosca de conexión cilíndrica (inglesa o métrica) con cierre hermético mediante junta anular de perfil, forma E según DIN 3852-11
- XGEV...LRK/SRK, XGEV...LMK/SMK, XGEV...LNPT/SNPT para rosca de conexión cónica (inglesa o métrica) con cierre hermético mediante rosca cónica, forma C según DIN 3852-2
- XGR...L/S para la transición a otros tamaños de conexión

**Einstellbare L-Stutzen mit Dichtkegel und O-Ring**

dichtkegelseitig vormontiert

**Adjustable L connectors with taper and O-ring**

pre-assembled on tapered nipple side

**Cuerpos L ajustables con junta cónica y junta tórica**

premontado en lado de junta cónica

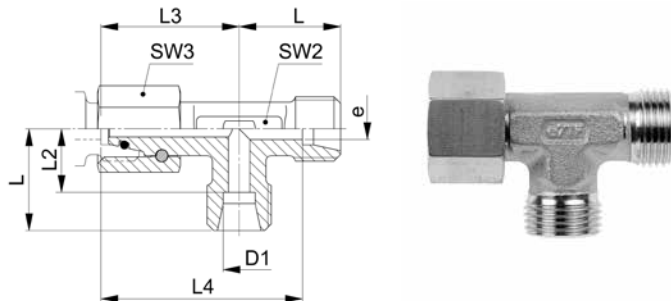

**XELKO-.L/S M**

Type-D1	Mat.-Nr.	PN	L	L2	L3	L4	SW2	SW3	e	g/Stk
XELKO-06L M	707.3671.060.20	315	19.0	12.0	26.0	38.0	12	14	3.0	43
XELKO-08L M	707.3671.080.20	315	21.0	14.0	27.5	41.5	12	17	4.0	56
XELKO-10L M	707.3671.100.20	315	22.0	15.0	29.0	44.0	14	19	6.0	71
XELKO-12L M	707.3671.120.20	315	24.0	17.0	29.5	46.5	17	22	8.0	92
XELKO-15L M	707.3671.150.20	315	28.0	21.0	32.5	53.5	19	27	10.0	159
XELKO-18L M	707.3671.180.20	315	31.0	23.5	35.5	59.0	24	32	13.0	221
XELKO-22L M	707.3671.220.20	160	35.0	27.5	38.5	66.0	27	36	17.0	310
XELKO-28L M	707.3671.280.20	160	38.0	30.5	41.5	72.0	36	46	22.0	469
XELKO-35L M	707.3671.350.20	160	45.0	34.5	51.0	85.5	41	50	28.0	700
XELKO-42L M	707.3671.420.20	160	51.0	40.0	56.0	96.0	50	60	34.0	1047
XELKO-06S M	707.3671.060.30	630	23.0	16.0	27.0	43.0	12	17	3.0	67
XELKO-08S M	707.3671.080.30	630	24.0	17.0	27.5	44.5	14	19	4.0	87
XELKO-10S M	707.3671.100.30	630	25.0	17.5	30.0	47.5	17	22	6.0	116
XELKO-12S M	707.3671.120.30	630	29.0	21.5	31.0	52.5	17	24	8.0	150
XELKO-14S M	707.3671.140.30	630	30.0	22.0	35.0	57.0	19	27	9.0	194
XELKO-16S M	707.3671.160.30	400	33.0	24.5	36.5	61.0	24	30	11.0	251
XELKO-20S M	707.3671.200.30	400	37.0	26.5	44.5	71.0	27	36	14.0	396
XELKO-25S M	707.3671.250.30	400	42.0	30.0	50.0	80.0	36	46	18.0	725
XELKO-30S M	707.3671.300.30	400	49.0	35.5	55.0	90.5	41	50	23.0	974
XELKO-38S M	707.3671.380.30	315	57.0	41.0	63.0	104.0	50	60	30.0	1496

Dichtungsmaterial: FKM

Sealing material: FKM

Material de junta tórica: FKM

**ISO 8434-1-SWORT**

**Einstellbare L-Verschraubungen mit Dichtkegel und O-Ring**  
**Adjustable L fittings with taper and O-ring**  
**Racores L ajustables con junta cónica y junta tórica**

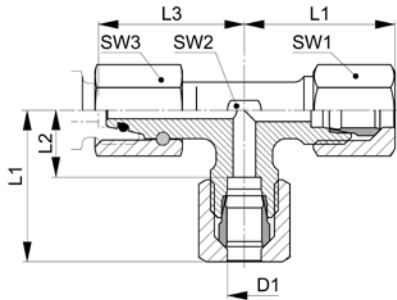

10

**ELKO-..L/S**

Type -D1	Mat.-Nr.	PN	L1	L2	L3	SW1	SW2	SW3	g/Stk
ELKO-06L	708.3671.060.20	315	27.0	12.0	26.0	14	12	14	53
ELKO-08L	708.3671.080.20	315	29.0	14.0	27.5	17	12	17	80
ELKO-10L	708.3671.100.20	315	30.0	15.0	29.0	19	14	19	109
ELKO-12L	708.3671.120.20	315	32.0	17.0	29.5	22	17	22	132
ELKO-15L	708.3671.150.20	315	36.0	21.0	32.5	27	19	27	223
ELKO-18L	708.3671.180.20	315	40.0	23.5	35.5	32	24	32	337
ELKO-22L	708.3671.220.20	160	44.0	27.5	38.5	36	27	36	439
ELKO-28L	708.3671.280.20	160	47.0	30.5	41.5	41	36	46	667
ELKO-35L	708.3671.350.20	160	56.0	34.5	51.0	50	41	50	1004
ELKO-42L	708.3671.420.20	160	63.0	40.0	56.0	60	50	60	1344
ELKO-06S	708.3671.060.30	630	31.0	16.0	27.0	17	12	17	89
ELKO-08S	708.3671.080.30	630	32.0	17.0	27.5	19	14	19	109
ELKO-10S	708.3671.100.30	630	34.0	17.5	30.0	22	17	22	170
ELKO-12S	708.3671.120.30	630	38.0	21.5	31.0	24	17	24	212
ELKO-14S	708.3671.140.30	630	40.0	22.0	35.0	27	19	27	277
ELKO-16S	708.3671.160.30	400	43.0	24.5	36.5	30	24	30	345
ELKO-20S	708.3671.200.30	400	48.0	26.5	44.5	36	27	36	548
ELKO-25S	708.3671.250.30	400	54.0	30.0	50.0	46	36	46	1036
ELKO-30S	708.3671.300.30	400	62.0	35.5	55.0	50	41	50	1341
ELKO-38S	708.3671.380.30	315	72.0	41.0	63.0	60	50	60	1964

Baumaße sind Ungefährmaße bei angezogener Überwurfmutter.

Sizes are approximate dimensions at tightened nut.

Las medidas son aproximadas con la tuerca de unión apretada.

Dichtungsmaterial: FKM

Sealing material: FKM

Material de junta tórica: FKM.

**ISO 8434-1-SWORTC**

**Einstellbare L-Stutzen mit Schaft**

schaftseitig vormontiert

**Adjustable standpipe L connectors**

pre-assembled on standpipe side

**Cuerpos L ajustables con vástago**

premontado en lado de vástago

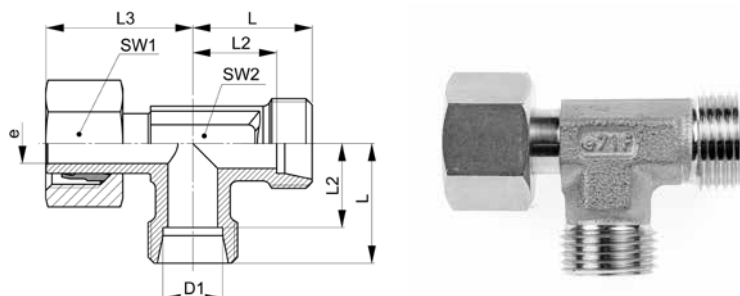

**XELV-..L/S M**

Type-D1	Mat.-Nr.	PN	L	L2	L3	SW1	SW2	e	g/Stk
XELV-06L M	707.3633.060.20	500	19.0	12.0	26.0	14	12	3.2	40
XELV-08L M	707.3633.080.20	500	21.0	14.0	27.5	17	12	5.0	51
XELV-10L M	707.3633.100.20	500	22.0	15.0	29.0	19	14	6.5	67
XELV-12L M	707.3633.120.20	400	24.0	17.0	29.5	22	17	8.0	87
XELV-15L M	707.3633.150.20	400	28.0	21.0	32.5	27	19	10.0	152
XELV-18L M	707.3633.180.20	400	31.0	23.5	35.5	32	24	13.0	214
XELV-22L M	707.3633.220.20	250	35.0	27.5	38.5	36	27	16.0	307
XELV-28L M	707.3633.280.20	250	38.0	30.5	41.5	41	36	22.0	435
XELV-35L M	707.3633.350.20	250	45.0	34.5	51.0	50	41	28.0	671
XELV-42L M	707.3633.420.20	250	51.0	40.0	56.0	60	50	34.0	1025
XELV-06S M	707.3633.060.30	800	23.0	16.0	27.0	17	12	3.2	62
XELV-08S M	707.3633.080.30	800	24.0	17.0	27.5	19	14	4.3	80
XELV-10S M	707.3633.100.30	800	25.0	17.5	30.0	22	17	6.0	108
XELV-12S M	707.3633.120.30	630	29.0	21.5	31.0	24	17	7.0	143
XELV-14S M	707.3633.140.30	630	30.0	22.0	35.0	27	19	9.0	182
XELV-16S M	707.3633.160.30	630	33.0	24.5	36.5	30	24	10.5	240
XELV-20S M	707.3633.200.30	420	37.0	26.5	44.5	36	27	14.0	377
XELV-25S M	707.3633.250.30	420	42.0	30.0	50.0	46	36	17.0	699
XELV-30S M	707.3633.300.30	420	49.0	35.5	55.0	50	41	22.0	936
XELV-38S M	707.3633.380.30	420	57.0	41.0	63.0	60	50	28.0	1462

Achtung: Endmontage des vormontierten Schaftes wird erst nach 1/4 Umdrehung der Überwurfmutter über den Punkt des deutlich fühlbaren Kraftanstiegs erreicht.

Attention: Final standpipe assembly, the nut will be tightened at least by 1/4 of a turn beyond the point of a noticeable increase in force.

Atención: El montaje del vástago premontado se completa girando 1/4 vuelta la tuerca de unión a partir del punto en que aumenta claramente la resistencia.

**Einstellbare L-Verschraubungen mit Schaft**  
**Adjustable standpipe L fittings**  
**Racores L ajustables con vástago**

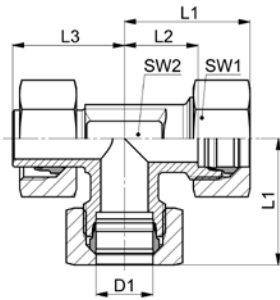

10

**ELV-..L/S**

Type -D1	Mat.-Nr.	PN	L1	L2	L3	SW1	SW2	g/Stk
ELV-06L	708.3630.060.20	500	27.0	12.0	26.0	14	12	60
ELV-08L	708.3630.080.20	500	29.0	14.0	27.5	17	12	85
ELV-10L	708.3630.100.20	500	30.0	15.0	29.0	19	14	115
ELV-12L	708.3630.120.20	400	32.0	17.0	29.5	22	17	135
ELV-15L	708.3630.150.20	400	36.0	21.0	32.5	27	19	240
ELV-18L	708.3630.180.20	400	40.0	23.5	35.5	32	24	340
ELV-22L	708.3630.220.20	250	44.0	27.5	38.5	36	27	464
ELV-28L	708.3630.280.20	250	47.0	30.5	41.5	41	36	604
ELV-35L	708.3630.350.20	250	56.0	34.5	51.0	50	41	941
ELV-42L	708.3630.420.20	250	63.0	40.0	56.0	60	50	1433
ELV-06S	708.3630.060.30	800	31.0	16.0	27.0	17	12	100
ELV-08S	708.3630.080.30	800	32.0	17.0	27.5	19	14	125
ELV-10S	708.3630.100.30	800	34.0	17.5	30.0	22	17	175
ELV-12S	708.3630.120.30	630	38.0	21.5	31.0	24	17	205
ELV-14S	708.3630.140.30	630	40.0	22.0	35.0	27	19	285
ELV-16S	708.3630.160.30	630	43.0	24.5	36.5	30	24	375
ELV-20S	708.3630.200.30	420	48.0	26.5	44.5	36	27	590
ELV-25S	708.3630.250.30	420	54.0	30.0	50.0	46	36	1130
ELV-30S	708.3630.300.30	420	62.0	35.5	55.0	50	41	1373
ELV-38S	708.3630.380.30	420	72.0	41.0	63.0	60	50	2070

Baumaße sind Ungefährmaße bei angezogener Überwurfmutter.

Sizes are approximate dimensions at tightened nut.

Las medidas son aproximadas con la tuerca de unión apretada.

Achtung: Endmontage des vormontierten Schaftes wird erst nach 1/4 Umdrehung der Überwurfmutter über den Punkt des deutlich fühlbaren Kraftanstiegs erreicht.

Attention: Final standpipe assembly, the nut will be tightened at least by 1/4 of a turn beyond the point of a noticeable increase in force.

Atención: El montaje del vástago premontado se completa girando 1/4 vuelta la tuerca de unión a partir del punto en que aumenta claramente la resistencia.

## Einstellbare L-Einschraubverschraubungen mit Schaft

mit Einschraubstutzen, Abdichtung durch Dichtkante Form B nach DIN 3852-2

## Adjustable male adaptor standpipe L fittings

with male adaptor connector, sealing edge form B acc. DIN 3852-2

## Racores L para roscar ajustables con vástago

con racor para roscar, cierre hermético mediante borde de obturación forma B según DIN 3852-2

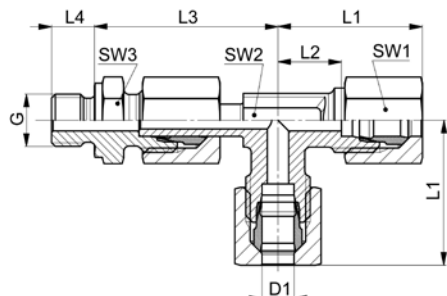

### ELV-..LR/SR

Type-D1 G	Mat.-Nr.	PN	G	L1	L2	L3	L4	SW1	SW2	SW3	g/Stk
G=Rohrgewinde (zylindrisch)		G=BSP thread (parallel)									
							G=rosca de conexión (cilíndrica)				
ELV-06LR 1.8	708.3652.100.20	500	1/8	27.0	12.0	34.5	10.0	14	12	14	77
ELV-08LR 1.4	708.3652.170.20	500	1/4	29.0	14.0	37.5	10.0	17	12	17	108
ELV-10LR 1.4	708.3652.270.20	500	1/4	30.5	15.0	40.0	11.0	19	14	19	129
ELV-12LR 3.8	708.3652.390.20	400	3/8	32.0	17.0	42.0	11.0	22	17	22	174
ELV-15LR 1.2	708.3652.534.20	400	1/2	36.5	21.0	46.5	12.0	27	19	27	296
ELV-18LR 1.2	708.3652.646.20	400	1/2	40.0	23.5	50.0	12.0	32	24	32	402
ELV-22LR 3.4	708.3652.768.20	250	3/4	44.5	27.5	55.0	14.0	36	27	36	582
ELV-28LR 1.1	708.3652.850.20	250	1	48.0	30.5	59.0	14.0	41	36	41	770
ELV-35LR 5.4	708.3652.944.20	250	1 1/4	57.0	34.5	68.5	16.0	50	41	50	1193
ELV-42LR 3.2	708.3652.992.20	250	1 1/2	63.5	40.0	75.5	16.0	60	50	60	1524
ELV-06SR 1.4	708.3652.111.30	800	1/4	31.0	16.0	40.0	12.0	17	12	17	127
ELV-08SR 1.4	708.3652.170.30	800	1/4	32.5	17.0	42.5	12.0	19	14	19	160
ELV-10SR 3.8	708.3652.280.30	800	3/8	35.0	17.5	45.0	12.0	22	17	22	223
ELV-12SR 3.8	708.3652.390.30	630	3/8	38.0	21.5	48.0	12.0	24	17	22	265
ELV-14SR 1.2	708.3652.504.30	630	1/2	41.0	22.0	54.0	14.0	27	19	27	377
ELV-16SR 1.2	708.3652.566.30	630	1/2	43.0	24.5	55.0	14.0	30	24	30	461
ELV-20SR 3.4	708.3652.704.30	420	3/4	50.0	26.5	67.0	14.0	36	27	36	788
ELV-25SR 1.1	708.3652.810.30	420	1	56.0	30.0	73.0	18.0	46	36	46	1477
ELV-30SR 5.4	708.3652.902.30	420	1 1/4	64.0	35.5	78.5	20.0	50	41	50	1796
ELV-38SR 3.2	708.3652.953.30	420	1 1/2	74.0	41.0	89.0	22.0	60	50	60	2189

Baumaße sind Ungefährmaße bei angezogener Überwurfmutter.

Achtung: Endmontage des vormontierten Schaftes wird erst nach 1/4 Umdrehung der Überwurfmutter über den Punkt des deutlich fühlbaren Kraftanstiegs erreicht.

Sizes are approximate dimensions at tightened nut.

Attention: Final standpipe assembly, the nut will be tightened at least by 1/4 of a turn beyond the point of a noticeable increase in force.

Las medidas son aproximadas con la tuerca de unión apretada.

Atención: El montaje del vástago premontado se completa girando 1/4 vuelta la tuerca de unión a partir del punto en que aumenta claramente la resistencia.

**Einstellbare L-Einschraubverschraubungen**

Für eine einstellbare L-Einschraubverschraubung kombinieren wir die einstellbare L-Verschraubung mit Schaft ELV-..L/S bzw. die einstellbare L-Verschraubung mit Dichtkegel ELKO-..L/S mit einem geraden Einschraubstutzen.

ELKO-..L/S + XGEV-..LR/SR = ELKO-..LR/SR  
 ELV-..L/S + XGEV-..LR/SR = ELV-..LR/SR

Weitere Kombinationen sind möglich:

**Adjustable male adaptor L fittings**

For an adjustable male adaptor L fitting we combine the adjustable standpipe L fitting ELV-..L/S resp. the adjustable L fitting with taper ELKO-..L/S with a straight male adaptor union.

ELKO-..L/S + XGEV-..LR/SR = ELKO-..LR/SR  
 ELV-..L/S + XGEV-..LR/SR = ELV-..LR/SR

Other combinations are possible:

**Racores para roscar L ajustables**

Para obtener un racor para roscar L ajustable combinamos el racor L ajustable con vástago ELV-..L/S o el racor L ajustable con junta cónica ELKO-..L/S con un racor para roscar recto.

ELKO-..L/S + XGEV-..LR/SR = ELKO-..LR/SR  
 ELV-..L/S + XGEV-..LR/SR = ELV-..LR/SR

Son posibles otras combinaciones:

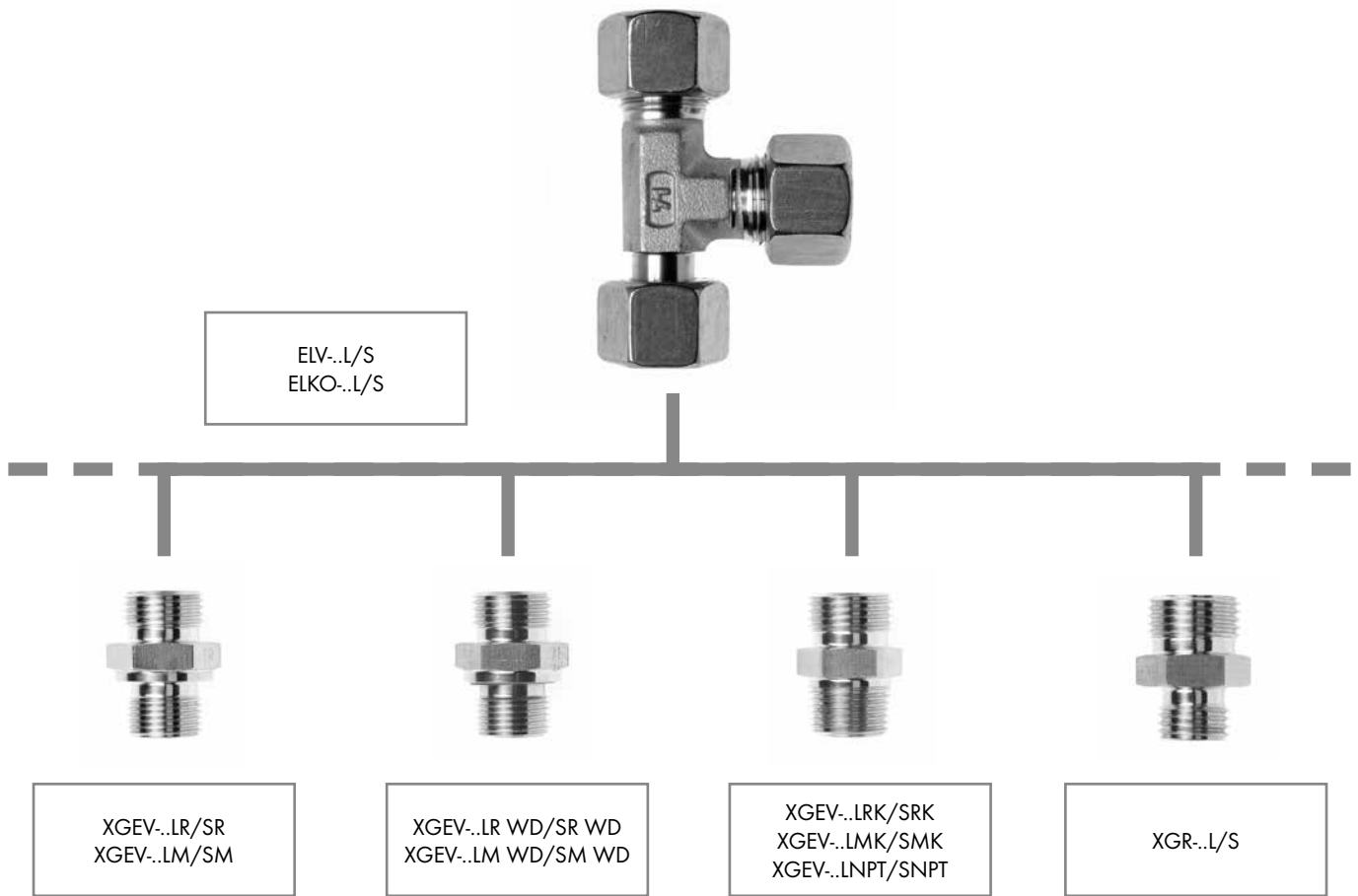

Kombination mit

- XGEV-..LR/SR, XGEV-..LM/SM für zylindrische Einschraubgewinde (zöllig bzw. metrisch) mit Abdichtung durch Dichtkante Form B nach DIN 3852-2
- XGEV-..LR WD/SR WD, XGEV-..LM WD/SM WD für zylindrische Einschraubgewinde (zöllig bzw. metrisch) mit Abdichtung durch Profildichtring Form E nach DIN 3852-11
- XGEV-..LRK/SRK, XGEV-..LMK/SMK, XGEV-..LNPT/SNPT für konische Einschraubgewinde (zöllig bzw. metrisch) mit Abdichtung im Kegelfgewinde Form C nach DIN 3852-2
- XGR-..L/S für den Übergang auf andere Anschlussgrößen

Combination with

- XGEV-..LR/SR, XGEV-..LM/SM for parallel male adaptor threads (English or metric) with sealing through seal edge form B acc. to DIN 3852-2
- XGEV-..LR WD/SR WD, XGEV-..LM WD/SM WD for parallel male adaptor threads (English or metric) with sealing through profile seal ring form E acc. to DIN 3852-11
- XGEV-..LRK/SRK, XGEV-..LMK/SMK, XGEV-..LNPT/SNPT for tapered male adaptor threads (English or metric) with taper thread sealing form C acc. to DIN 3852-2
- XGR-..L/S for transitioning to other connection sizes

Combinación con

- XGEV-..LR/SR, XGEV-..LM/SM para rosca de conexión cilíndrica (inglesa o métrica) con cierre hermético mediante junta de obturación según DIN 3852-2
- XGEV-..LR WD/SR WD, XGEV-..LM WD/SM WD para rosca de conexión cilíndrica (inglesa o métrica) con cierre hermético mediante junta anular de perfil, forma E según DIN 3852-11
- XGEV-..LRK/SRK, XGEV-..LMK/SMK, XGEV-..LNPT/SNPT para rosca de conexión cónica (inglesa o métrica) con cierre hermético mediante rosca cónica, forma C según DIN 3852-2
- XGR-..L/S para la transición a otros tamaños de conexión

## Winkel-Schwenkstutzen

Abdichtung mit metallischem Dichtkantenring

## Banjo elbow connectors

sealing with metal seal-edge ring

## Cuerpos orientables angulares

junta con anillo con borde de obturación metálico

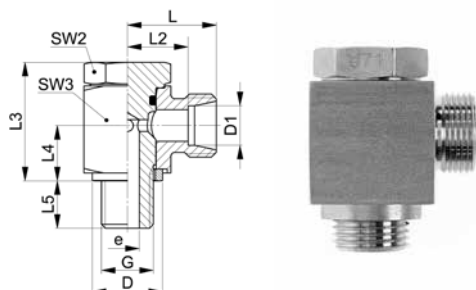

### XESWV-..LR/SR

Type-D1 G	Mat.-Nr.	PN	G	D	L	L2	L3	L4	L5	SW2	SW3	e	g/Stk
G=Rohrgewinde (zylindrisch)		G=BSP thread (parallel)			G=rosca de conexión (cilíndrica)								
XESWV-06LLR 1.8	707.2850.100.10	100	1/8	14.0	15.5	10.0	21.0	10.0	8.0	14	15	4.5	36
XESWV-08LLR 1.8	707.2850.160.10	100	1/8	14.0	16.5	11.0	21.0	10.0	8.0	14	15	4.5	44
XESWV-06LR 1.8	707.2850.100.20	500	1/8	14.0	19.0	12.0	21.0	10.5	8.0	14	17	4.5	48
XESWV-06LR 1.4	707.2850.110.20	500	1/4	18.0	19.0	12.0	30.0	14.0	12.0	19	19	6.0	48
XESWV-08LR 1.4	707.2850.170.20	500	1/4	18.0	21.5	14.5	30.0	14.0	12.0	19	22	6.0	76
XESWV-10LR 1.4	707.2850.270.20	500	1/4	18.0	22.5	15.5	30.0	14.0	12.0	19	22	6.0	81
XESWV-12LR 1.4	707.2850.380.20	500	1/4	18.0	25.0	18.0	30.0	14.0	12.0	19	22	6.0	129
XESWV-12LR 3.8	707.2850.390.20	500	3/8	21.0	25.0	18.0	34.5	16.5	12.0	22	27	7.5	130
XESWV-15LR 1.2	707.2850.534.20	500	1/2	27.0	28.5	21.5	44.0	21.5	14.0	27	32	10.5	237
XESWV-18LR 1.2	707.2850.646.20	400	1/2	27.0	28.5	21.5	44.0	21.5	14.0	27	32	10.5	251
XESWV-22LR 3.4	707.2850.768.20	250	3/4	32.0	35.0	27.5	49.0	24.0	16.0	32	41	16.0	395
XESWV-28LR 1.1	707.2850.850.20	250	1	39.0	39.5	32.0	60.0	30.5	18.0	41	46	20.0	776
XESWV-35LR 5.4	707.2850.944.20	250	1 1/4	49.0	46.5	36.0	74.0	35.5	20.0	50	55	26.0	1345
XESWV-42LR 3.2	707.2850.992.20	250	1 1/2	55.0	51.5	40.5	84.0	40.5	22.0	55	65	32.0	2088
XESWV-06SR 1.4	707.2850.110.30	800	1/4	18.0	23.5	16.5	30.0	14.0	12.0	19	22	6.0	68
XESWV-08SR 1.4	707.2850.170.30	800	1/4	18.0	23.5	16.5	30.0	14.0	12.0	19	22	6.0	81
XESWV-10SR 3.8	707.2850.280.30	800	3/8	21.0	26.0	18.5	34.5	16.5	12.0	22	27	7.5	136
XESWV-12SR 3.8	707.2850.390.30	630	3/8	21.0	26.0	18.5	34.5	16.5	12.0	22	27	7.5	142
XESWV-14SR 1.2	707.2850.504.30	630	1/2	27.0	30.5	22.5	44.0	21.5	14.0	27	32	10.5	246
XESWV-16SR 1.2	707.2850.566.30	630	1/2	27.0	30.5	22.0	44.0	21.5	14.0	27	32	10.5	245
XESWV-20SR 3.4	707.2850.704.30	420	3/4	32.0	37.0	26.5	49.0	24.0	16.0	32	41	16.0	405
XESWV-25SR 1.1	707.2850.810.30	420	1	39.0	43.5	31.5	60.0	30.5	18.0	41	46	20.0	805
XESWV-30SR 5.4	707.2850.902.30	420	1 1/4	49.0	50.5	37.0	74.0	35.5	20.0	50	55	26.0	1389
XESWV-38SR 3.2	707.2850.953.30	420	1 1/2	55.0	57.5	41.5	84.0	40.5	22.0	55	65	32.0	2264

Dichtungsmaterial: FKM

Sealing material: FKM

Material de junta tórica: FKM

optional auch in rein metallischer Ausführung ohne O-Ring erhältlich

optionally available as pure metallic version without O-ring

opcionalmente disponible como versión metálica sin junta tórica

G	1/8	1/4	3/8	1/2	3/4	1	1 1/4	1 1/2
[Nm]	15	40	70	110	160	210	360	540

Anzugsdrehmoment für HohlSchraube in Nm

Tightening torque for hollow bolt in Nm

Pares de apriete para tornillo hueco en Nm

## Winkel-Schwenkverschraubungen

Abdichtung mit metallischem Dichtkantenring

### Banjo elbow fittings

sealing with metal seal-edge ring

### Racores orientables angulares

junta con anillo con borde de obturación metálico

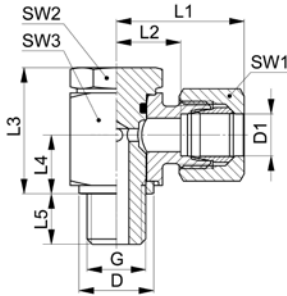

10

## ESWV-..LR/SR

Type-D1 G	Mat.-Nr.	PN	G	D	L1	L2	L3	L4	L5	SW1	SW2	SW3	g/Stk
G=Rohrgewinde (zylindrisch)		G=BSP thread (parallel)			G=rosca de conexión (cilíndrica)								
ESWV-06LLR 1.8	708.2850.100.10	100	1/8	14.0	21.5	10.0	21.0	10.0	8.0	12	14	15	42
ESWV-08LLR 1.8	708.2850.160.10	100	1/8	14.0	22.5	11.0	21.0	10.0	8.0	14	14	15	52
ESWV-06LR 1.8	708.2850.100.20	500	1/8	14.0	27.0	12.0	21.0	10.5	8.0	14	14	17	59
ESWV-06LR 1.4	708.2850.110.20	500	1/4	18.0	27.0	12.0	30.0	14.0	12.0	14	19	19	59
ESWV-08LR 1.4	708.2850.170.20	500	1/4	18.0	29.5	14.5	30.0	14.0	12.0	17	19	22	93
ESWV-10LR 1.4	708.2850.270.20	500	1/4	18.0	30.5	15.5	30.0	14.0	12.0	19	19	22	102
ESWV-12LR 1.4	708.2850.380.20	500	1/4	18.0	33.0	18.0	30.0	14.0	12.0	22	19	22	158
ESWV-12LR 3.8	708.2850.390.20	500	3/8	21.0	33.0	18.0	34.5	16.5	12.0	22	22	27	159
ESWV-15LR 1.2	708.2850.534.20	500	1/2	27.0	36.5	21.5	44.0	21.5	14.0	27	27	32	284
ESWV-18LR 1.2	708.2850.646.20	400	1/2	27.0	37.5	21.5	44.0	21.5	14.0	32	27	32	320
ESWV-22LR 3.4	708.2850.768.20	250	3/4	32.0	44.0	27.5	49.0	24.0	16.0	36	32	41	485
ESWV-28LR 1.1	708.2850.850.20	250	1	39.0	48.5	32.0	60.0	30.5	18.0	41	41	46	882
ESWV-35LR 5.4	708.2850.944.20	250	1 1/4	49.0	57.5	36.0	74.0	35.5	20.0	50	50	55	1508
ESWV-42LR 3.2	708.2850.992.20	250	1 1/2	55.0	63.5	40.5	84.0	40.5	22.0	60	55	65	2341
ESWV-06SR 1.4	708.2850.110.30	800	1/4	18.0	31.5	16.5	30.0	14.0	12.0	17	19	22	87
ESWV-08SR 1.4	708.2850.170.30	800	1/4	18.0	31.5	16.5	30.0	14.0	12.0	19	19	22	103
ESWV-10SR 3.8	708.2850.280.30	800	3/8	21.0	35.0	18.5	34.5	16.5	12.0	22	22	27	170
ESWV-12SR 3.8	708.2850.390.30	630	3/8	21.0	35.0	18.5	34.5	16.5	12.0	24	22	27	179
ESWV-14SR 1.2	708.2850.504.30	630	1/2	27.0	40.5	22.5	44.0	21.5	14.0	27	27	32	303
ESWV-16SR 1.2	708.2850.566.30	630	1/2	27.0	40.5	22.0	44.0	21.5	14.0	30	27	32	316
ESWV-20SR 3.4	708.2850.704.30	420	3/4	32.0	48.0	26.5	49.0	24.0	16.0	36	32	41	518
ESWV-25SR 1.1	708.2850.810.30	420	1	39.0	55.5	31.5	60.0	30.5	18.0	46	41	46	1030
ESWV-30SR 5.4	708.2850.902.30	420	1 1/4	49.0	63.5	37.0	74.0	35.5	20.0	50	50	55	1637
ESWV-38SR 3.2	708.2850.953.30	420	1 1/2	55.0	72.5	41.5	84.0	40.5	22.0	60	55	65	2627

Baumaße sind Ungefährmaße bei angezogener Überwurfmutter.

Sizes are approximate dimensions at tightened nut.

Las medidas son aproximadas con la tuerca de unión apretada.

Dichtungsmaterial: FKM

Sealing material: FKM

Material de junta tórica: FKM

optional auch in rein metallischer Ausführung ohne O-Ring erhältlich

optionally available as pure metallic version without O-ring

opcionalmente disponible como versión metálica sin junta tórica

G	1/8	1/4	3/8	1/2	3/4	1	1 1/4	1 1/2
[Nm]	15	40	70	110	160	210	360	540

**Winkel-Schwenkstutzen**

Abdichtung mit gekammertem FKM Weichdichtring

**Banjo elbow connectors**

sealing with restraining FKM seal ring

**Cuerpos orientables angulares**

junta con junta anular FKM blanda protegida

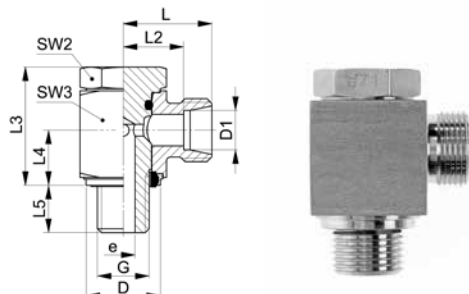

**XESWV-..LR WD/SR WD**

Type-D1 G	Mat.-Nr.	PN	G	D	L	L2	L3	L4	L5	SW2	SW3	e	g/Stk
G=Rohrgewinde (zylindrisch)		G=BSP thread (parallel)			G=rosca de conexión (cilíndrica)								
XESWV-06LLR 1.8 WD	707.2851.100.10	100	1/8	15.0	15.5	10.0	21.0	10.0	8.0	14	15	4.5	36
XESWV-08LLR 1.8 WD	707.2851.160.10	100	1/8	15.0	16.5	11.0	21.0	10.0	8.0	14	15	4.5	44
XESWV-06LR 1.8 WD	707.2851.100.20	500	1/8	15.0	19.0	12.0	21.0	10.5	8.0	14	17	4.5	48
XESWV-06LR 1.4 WD	707.2851.110.20	500	1/4	19.0	19.0	12.0	30.0	14.0	12.0	19	19	6.0	48
XESWV-08LR 1.4 WD	707.2851.170.20	500	1/4	19.0	21.5	14.5	30.0	14.0	12.0	19	22	6.0	76
XESWV-10LR 1.4 WD	707.2851.270.20	500	1/4	19.0	22.5	15.5	30.0	14.0	12.0	19	22	6.0	81
XESWV-12LR 1.4 WD	707.2851.380.20	500	1/4	19.0	25.0	18.0	30.0	14.0	12.0	19	22	6.0	129
XESWV-12LR 3.8 WD	707.2851.390.20	500	3/8	22.0	25.0	18.0	34.5	16.5	12.0	22	27	7.5	130
XESWV-15LR 1.2 WD	707.2851.534.20	500	1/2	27.0	28.5	21.5	44.0	21.5	14.0	27	32	10.5	237
XESWV-18LR 1.2 WD	707.2851.646.20	400	1/2	27.0	28.5	21.5	44.0	21.5	14.0	27	32	10.5	251
XESWV-22LR 3.4 WD	707.2851.768.20	250	3/4	33.0	35.0	27.5	49.0	24.0	16.0	32	41	16.0	395
XESWV-28LR 1.1 WD	707.2851.850.20	250	1	40.0	39.5	32.0	60.0	30.5	18.0	41	46	20.0	776
XESWV-35LR 5.4 WD	707.2851.944.20	250	1 1/4	50.0	46.5	36.0	74.0	35.5	20.0	50	55	26.0	1345
XESWV-42LR 3.2 WD	707.2851.992.20	250	1 1/2	56.0	51.5	40.5	84.0	40.5	22.0	55	65	32.0	2088
XESWV-06SR 1.4 WD	707.2851.110.30	800	1/4	19.0	23.5	16.5	30.0	14.0	12.0	19	22	6.0	68
XESWV-08SR 1.4 WD	707.2851.170.30	800	1/4	19.0	23.5	16.5	30.0	14.0	12.0	19	22	6.0	81
XESWV-10SR 3.8 WD	707.2851.280.30	800	3/8	22.0	26.0	18.5	34.5	16.5	12.0	22	27	7.5	136
XESWV-12SR 3.8 WD	707.2851.390.30	630	3/8	22.0	26.0	18.5	34.5	16.5	12.0	22	27	7.5	142
XESWV-14SR 1.2 WD	707.2851.504.30	630	1/2	27.0	30.5	22.5	44.0	21.5	14.0	27	32	10.5	246
XESWV-16SR 1.2 WD	707.2851.566.30	630	1/2	27.0	30.5	22.0	44.0	21.5	14.0	27	32	10.5	245
XESWV-20SR 3.4 WD	707.2851.704.30	420	3/4	33.0	37.0	26.5	49.0	24.0	16.0	32	41	16.0	405
XESWV-25SR 1.1 WD	707.2851.810.30	420	1	40.0	43.5	31.5	60.0	30.5	18.0	41	46	20.0	805
XESWV-30SR 5.4 WD	707.2851.902.30	420	1 1/4	50.0	50.5	37.0	74.0	35.5	20.0	50	55	26.0	1389
XESWV-38SR 3.2 WD	707.2851.953.30	420	1 1/2	55.0	57.5	41.5	84.0	40.5	22.0	55	65	32.0	2264

Dichtungsmaterial: FKM

Sealing material: FKM

Material de junta tórica: FKM

G	1/8	1/4	3/8	1/2	3/4	1	1 1/4	1 1/2
[Nm]	15	40	70	110	160	210	360	540

Anzugsdrehmoment für Hohlschraube in Nm      Tightening torque for hollow bolt in Nm      Pares de apriete para tornillo hueco en Nm

## Winkel-Schwenkverschraubungen

Abdichtung mit gekammertem FKM Weichdichtring

### Banjo elbow fittings

sealing with restraining seal ring FKM

### Racores orientables angulares

junta con anillo retentivo FKM blanda

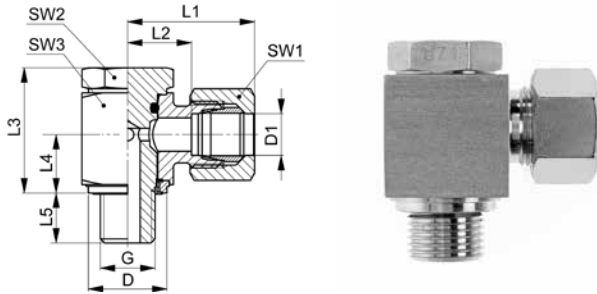

10

## ESWV-..LR WD/SR WD

Type-D1 G	Mat.-Nr.	PN	G	D	L1	L2	L3	L4	L5	SW1	SW2	SW3	g/Stk
G=Rohrgewinde (zylindrisch)		G=BSP thread (parallel)			G=rosca de conexión (cilíndrica)								
ESWV-06LLR 1.8 WD	708.2851.100.10	100	1/8	15.0	21.5	10.0	21.0	10.0	8.0	12	14	15	42
ESWV-08LLR 1.8 WD	708.2851.160.10	100	1/8	15.0	22.5	11.0	21.0	10.0	8.0	14	14	15	52
ESWV-06LR 1.8 WD	708.2851.100.20	500	1/8	15.0	27.0	12.0	21.0	10.5	8.0	14	14	17	59
ESWV-06LR 1.4 WD	708.2851.110.20	500	1/4	19.0	27.0	12.0	30.0	14.0	12.0	14	19	19	59
ESWV-08LR 1.4 WD	708.2851.170.20	500	1/4	19.0	29.5	14.5	30.0	14.0	12.0	17	19	22	93
ESWV-10LR 1.4 WD	708.2851.270.20	500	1/4	19.0	30.5	15.5	30.0	14.0	12.0	19	19	22	102
ESWV-12LR 1.4 WD	708.2851.380.20	500	1/4	19.0	33.0	18.0	30.0	14.0	12.0	22	19	22	158
ESWV-12LR 3.8 WD	708.2851.390.20	500	3/8	22.0	33.0	18.0	34.5	16.5	12.0	22	22	27	159
ESWV-15LR 1.2 WD	708.2851.534.20	500	1/2	27.0	36.5	21.5	44.0	21.5	14.0	27	27	32	284
ESWV-18LR 1.2 WD	708.2851.646.20	400	1/2	27.0	37.5	21.5	44.0	21.5	14.0	32	27	32	320
ESWV-22LR 3.4 WD	708.2851.768.20	250	3/4	33.0	44.0	27.5	49.0	24.0	16.0	36	32	41	485
ESWV-28LR 1.1 WD	708.2851.850.20	250	1	40.0	48.5	32.0	60.0	30.5	18.0	41	41	46	882
ESWV-35LR 5.4 WD	708.2851.944.20	250	1 1/4	50.0	57.5	36.0	74.0	35.5	20.0	50	50	55	1508
ESWV-42LR 3.2 WD	708.2851.992.20	250	1 1/2	56.0	63.5	40.5	84.0	40.5	22.0	60	55	65	2341
ESWV-06SR 1.4 WD	708.2851.110.30	800	1/4	19.0	31.5	16.5	30.0	14.0	12.0	17	19	22	87
ESWV-08SR 1.4 WD	708.2851.170.30	800	1/4	19.0	31.5	16.5	30.0	14.0	12.0	19	19	22	103
ESWV-10SR 3.8 WD	708.2851.280.30	800	3/8	22.0	35.0	18.5	34.5	16.5	12.0	22	22	27	170
ESWV-12SR 3.8 WD	708.2851.390.30	630	3/8	22.0	35.0	18.5	34.5	16.5	12.0	24	22	27	179
ESWV-14SR 1.2 WD	708.2851.504.30	630	1/2	27.0	40.5	22.5	44.0	21.5	14.0	27	27	32	303
ESWV-16SR 1.2 WD	708.2851.566.30	630	1/2	27.0	40.5	22.0	44.0	21.5	14.0	30	27	32	316
ESWV-20SR 3.4 WD	708.2851.704.30	420	3/4	33.0	48.0	26.5	49.0	24.0	16.0	36	32	41	518
ESWV-25SR 1.1 WD	708.2851.810.30	420	1	40.0	55.5	31.5	60.0	30.5	18.0	46	41	46	1030
ESWV-30SR 5.4 WD	708.2851.902.30	420	1 1/4	50.0	63.5	37.0	74.0	35.5	20.0	50	50	55	1637
ESWV-38SR 3.2 WD	708.2851.953.30	420	1 1/2	56.0	72.5	41.5	84.0	40.5	22.0	60	55	65	2627

Baumaße sind Ungefährmaße bei angezogener Überwurfmutter.

Sizes are approximate dimensions at tightened nut.

Las medidas son aproximadas con la tuerca de unión apretada.

Dichtungsmaterial: FKM

Sealing material: FKM

Material de junta tórica: FKM

G	1/8	1/4	3/8	1/2	3/4	1	1 1/4	1 1/2
[Nm]	15	40	70	110	160	210	360	540

Anzugsdrehmoment für Hohlschraube in Nm

Tightening torque for hollow bolt in Nm

Pares de apriete para tornillo hueco en Nm

**Winkel-Schwenkstutzen**

Abdichtung mit metallischem Dichtkantenring

**Banjo elbow connectors**

sealing with metal seal-edge ring

**Cuerpos orientables angulares**

junta con anillo con borde de obturación metálico

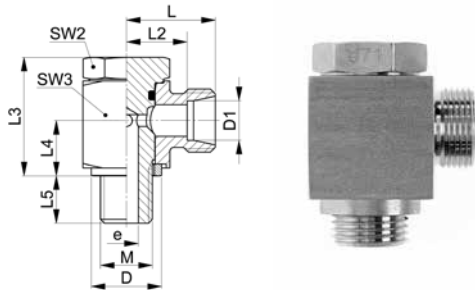

**XESWV-..LM/SM**

Type-D1 M	Mat.-Nr.	PN	M	D	L	L2	L3	L4	L5	SW2	SW3	e	g/Stk
M=metrisches Gewinde (zylindrisch)	M=metric thread (parallel)	M=rosca métrica (cilíndrica)											
XESWV-06LLM 10x1,0	707.2853.180.10	100	10x1.0	14.0	15.5	10.0	21.0	10.0	8.0	14	15	4.5	36
XESWV-08LLM 10x1,0	707.2853.230.10	100	10x1.0	14.0	16.5	11.0	21.0	10.0	8.0	14	15	4.5	37
XESWV-06LM 10x1,0	707.2853.180.20	500	10x1.0	14.0	19.0	12.0	21.0	10.5	8.0	14	17	4.5	48
XESWV-08LM 12x1,5	707.2853.240.20	500	12x1.5	18.0	21.5	14.5	30.0	14.0	12.0	19	22	6.0	73
XESWV-10LM 14x1,5	707.2853.280.20	500	14x1.5	18.0	22.5	15.5	30.0	14.0	12.0	19	22	6.0	82
XESWV-12LM 16x1,5	707.2853.330.20	500	16x1.5	21.0	25.0	18.0	34.5	16.5	12.0	22	27	7.5	129
XESWV-15LM 18x1,5	707.2853.390.20	500	18x1.5	23.0	28.5	21.5	38.5	18.5	12.0	24	27	9.0	162
XESWV-18LM 22x1,5	707.2853.460.20	500	22x1.5	27.0	28.5	21.0	44.0	21.5	14.0	27	32	10.5	251
XESWV-22LM 26x1,5	707.2853.535.20	250	26x1.5	32.0	35.0	27.5	49.0	24.0	16.0	32	41	16.0	395
XESWV-28LM 33x2,0	707.2853.570.20	250	33x2.0	39.0	39.5	32.0	60.0	30.5	18.0	41	46	20.0	776
XESWV-35LM 42x2,0	707.2853.600.20	250	42x2.0	49.0	46.5	36.0	74.0	35.5	20.0	50	55	26.0	1345
XESWV-42LM 48x2,0	707.2853.992.20	250	48x2.0	55.0	51.5	40.5	84.0	40.5	22.0	55	65	32.0	2088
XESWV-06SM 12x1,5	707.2853.195.30	800	12x1.5	18.0	23.5	16.5	30.0	14.0	12.0	19	22	6.0	66
XESWV-08SM 14x1,5	707.2853.245.30	800	14x1.5	18.0	23.5	16.5	30.0	14.0	12.0	19	22	6.0	81
XESWV-10SM 16x1,5	707.2853.285.30	800	16x1.5	21.0	26.0	18.5	34.5	16.5	12.0	22	27	7.5	136
XESWV-12SM 18x1,5	707.2853.333.30	630	18x1.5	23.0	27.5	20.0	38.5	18.5	12.0	24	27	9.0	183
XESWV-14SM 20x1,5	707.2853.382.30	630	20x1.5	26.0	30.5	22.5	44.0	21.5	14.0	27	32	10.5	223
XESWV-16SM 22x1,5	707.2853.410.30	630	22x1.5	27.0	30.5	22.0	44.0	21.5	14.0	27	32	10.5	249
XESWV-20SM 27x2,0	707.2853.506.30	420	27x2.0	32.0	37.0	26.5	49.0	24.0	16.0	32	41	16.0	405
XESWV-25SM 33x2,0	707.2853.550.30	420	30x2.0	39.0	43.5	31.5	60.0	30.5	18.0	41	46	20.0	805
XESWV-30SM 42x2,0	707.2853.600.30	420	42x2.0	49.0	50.5	37.0	74.0	35.5	20.0	50	55	26.0	1392
XESWV-38SM 48x2,0	707.2853.954.30	420	48x2.0	55.0	57.5	41.5	84.0	40.5	22.0	55	65	32.0	2167

Dichtungsmaterial: FKM

Sealing material: FKM

Material de junta tórica: FKM

optional auch in rein metallischer Ausführung ohne O-Ring erhältlich

optionally available as pure metallic version without O-ring

opcionalmente disponible como versión metálica sin junta tórica

M	10x1.0	12/14x1.5	16x1.5	18x1.5	20x1.5	22x1.5	26x1.5	27x2.0	33x2.0	42x2.0	48x2.0
[Nm]	15	25	45	60	110	80	150	160	210	360	540

Anzugsdrehmoment für Hohlschraube in Nm

Tightening torque for hollow bolt in Nm

Pares de apriete para tornillo hueco en Nm

## Winkel-Schwenkverschraubungen

Abdichtung mit metallischem Dichtkantenring

### Banjo elbow fittings

sealing with metal seal-edge ring

### Racores orientables angulares

junta con anillo con borde de obturación metálico

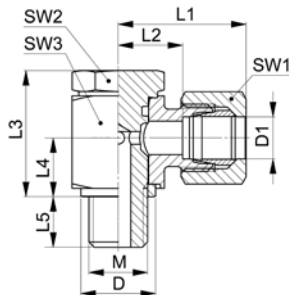

10

### ESWV-..LM/SM

Type-D1 M	Mat.-Nr.	PN	M	D	L1	L2	L3	L4	L5	SW1	SW2	SW3	g/Stk
M=metrisches Gewinde (zylindrisch)	M=metric thread (parallel)	M=rosca métrica (cilíndrica)											
ESWV-06LLM 10x1,0	708.2853.180.10	100	10x1.0	14.0	21.5	10.0	21.0	10.0	8.0	12	14	15	42
ESWV-08LLM 10x1,0	708.2853.230.10	100	10x1.0	14.0	22.5	11.0	21.0	10.0	8.0	14	14	15	45
ESWV-06LM 10x1,0	708.2853.180.20	500	10x1.0	14.0	27.0	12.0	21.0	10.5	8.0	14	14	17	59
ESWV-08LM 12x1,5	708.2853.240.20	500	12x1.5	18.0	29.5	14.5	30.0	14.0	12.0	17	19	22	90
ESWV-10LM 14x1,5	708.2853.280.20	500	14x1.5	18.0	30.5	15.5	30.0	14.0	12.0	19	19	22	103
ESWV-12LM 16x1,5	708.2853.330.20	500	16x1.5	21.0	33.0	18.0	34.5	16.5	12.0	22	22	27	158
ESWV-15LM 18x1,5	708.2853.390.20	500	18x1.5	23.0	36.5	21.5	38.5	18.5	12.0	27	24	27	209
ESWV-18LM 22x1,5	708.2853.460.20	500	22x1.5	27.0	37.5	21.0	44.0	21.5	14.0	32	27	32	320
ESWV-22LM 26x1,5	708.2853.535.20	250	26x1.5	32.0	44.0	27.5	49.0	24.0	16.0	36	32	41	485
ESWV-28LM 33x2,0	708.2853.570.20	250	33x2.0	39.0	48.5	32.0	60.0	30.5	18.0	41	41	46	882
ESWV-35LM 42x2,0	708.2853.600.20	250	42x2.0	49.0	57.5	36.0	74.0	35.5	20.0	50	50	55	1508
ESWV-42LM 48x2,0	708.2853.992.20	250	48x2.0	55.0	63.5	40.5	84.0	40.5	22.0	60	55	65	2341
ESWV-06SM 12x1,5	708.2853.195.30	800	12x1.5	18.0	31.5	16.5	30.0	14.0	12.0	17	19	22	85
ESWV-08SM 14x1,5	708.2853.245.30	800	14x1.5	18.0	31.5	16.5	30.0	14.0	12.0	19	19	22	103
ESWV-10SM 16x1,5	708.2853.285.30	800	16x1.5	21.0	35.0	18.5	34.5	16.5	12.0	22	22	27	170
ESWV-12SM 18x1,5	708.2853.333.30	630	18x1.5	23.0	36.5	20.0	38.5	18.5	12.0	24	24	27	220
ESWV-14SM 20x1,5	708.2853.382.30	630	20x1.5	27.0	40.5	22.5	44.0	21.5	14.0	27	27	32	280
ESWV-16SM 22x1,5	708.2853.410.30	630	22x1.5	27.0	40.5	22.0	44.0	21.5	14.0	30	27	32	320
ESWV-20SM 27x2,0	708.2853.506.30	420	27x2.0	32.0	48.0	26.5	49.0	24.0	16.0	36	32	41	518
ESWV-25SM 33x2,0	708.2853.550.30	420	33x2.0	39.0	55.5	31.5	60.0	30.5	18.0	46	41	46	1030
ESWV-30SM 42x2,0	708.2853.600.30	420	42x2.0	49.0	63.5	37.0	74.0	35.5	20.0	50	50	55	1640
ESWV-38SM 48x2,0	708.2853.954.30	420	48x2.0	55.0	72.5	41.5	84.0	40.5	22.0	60	55	65	2530

Baumaße sind Ungefährmaße bei angezogener Überwurfmutter.

Sizes are approximate dimensions at tightened nut.

Las medidas son aproximadas con la tuerca de unión apretada.

Dichtungsmaterial: FKM

Sealing material: FKM

Material de junta tórica: FKM

optional auch in rein metallischer Ausführung ohne O-Ring erhältlich

optionally available as pure metallic version without O-ring

opcionalmente disponible como versión metálica sin junta tórica

M	10x1.0	12/14x1.5	16x1.5	18x1.5	20x1.5	22x1.5	26x1.5	27x2.0	33x2.0	42x2.0	48x2.0
[Nm]	15	25	45	60	110	80	150	160	210	360	540

**Winkel-Schwenkstutzen**

Abdichtung mit gekammertem FKM Weichdichtring

**Banjo elbow connectors**

sealing with restraining FKM seal ring

**Cuerpos orientables angulares**

junta con junta anular FKM blanda protegida

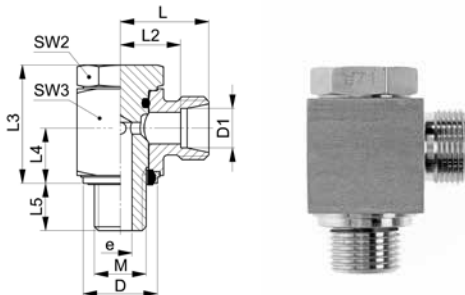

**XESWV-..LM WD/SM WD**

Type-D1 M	Mat.-Nr.	PN	M	D	L	L2	L3	L4	L5	SW2	SW3	e	g/Stk
M=metrisches Gewinde (zylindrisch)	M=metric thread (parallel)	M=rosca métrica (cilindrica)											
XESWV-06LLM 10x1,0 WD	707.2852.180.10	100	10x1.0	15.0	15.5	10.0	21.0	10.0	8.0	14	15	4.5	36
XESWV-08LLM 10x1,0 WD	707.2852.230.10	100	10x1.0	15.0	16.5	11.0	21.0	10.0	8.0	14	15	4.5	37
XESWV-06LM 10x1,0 WD	707.2852.180.20	500	10x1.0	15.0	19.0	12.0	21.0	10.5	8.0	14	17	4.5	48
XESWV-08LM 12x1,5 WD	707.2852.240.20	500	12x1.5	19.0	21.5	14.5	30.0	14.0	12.0	19	22	6.0	73
XESWV-10LM 14x1,5 WD	707.2852.280.20	500	14x1.0	19.0	22.5	15.5	30.0	14.0	12.0	19	22	6.0	82
XESWV-12LM 16x1,5 WD	707.2852.330.20	500	16x1.5	22.0	25.0	18.0	34.5	16.5	12.0	22	27	7.5	129
XESWV-15LM 18x1,5 WD	707.2852.390.20	500	18x1.5	24.0	28.5	21.5	38.5	18.5	12.0	24	27	9.0	162
XESWV-18LM 22x1,5 WD	707.2852.460.20	500	22x1.5	27.0	28.5	21.0	44.0	21.5	14.0	27	32	10.5	251
XESWV-22LM 26x1,5 WD	707.2852.535.20	250	26x1.5	33.0	35.0	27.5	49.0	24.0	16.0	32	41	16.0	395
XESWV-28LM 33x2,0 WD	707.2852.570.20	250	33x2.0	40.0	39.5	32.0	60.0	30.5	18.0	41	46	20.0	776
XESWV-35LM 42x2,0 WD	707.2852.600.20	250	42x2.0	50.0	46.5	36.0	74.0	35.5	20.0	50	55	26.0	1345
XESWV-42LM 48x2,0 WD	707.2852.992.20	250	48x2.0	56.0	51.5	40.5	84.0	40.5	22.0	55	65	32.0	2088
XESWV-06SM 12x1,5 WD	707.2852.195.30	800	12x1.5	19.0	23.5	16.5	30.0	14.0	12.0	19	22	6.0	66
XESWV-08SM 14x1,5 WD	707.2852.245.30	800	14x1.5	19.0	23.5	16.5	30.0	14.0	12.0	19	22	6.0	81
XESWV-10SM 16x1,5 WD	707.2852.285.30	800	16x1.5	22.0	26.0	18.5	34.5	16.5	12.0	22	27	7.5	136
XESWV-12SM 18x1,5 WD	707.2852.333.30	630	18x1.5	24.0	27.5	20.0	38.5	18.5	12.0	24	27	9.0	183
XESWV-14SM 20x1,5 WD	707.2852.382.30	630	20x1.5	27.0	30.5	22.5	44.0	21.5	14.0	27	32	10.5	223
XESWV-16SM 22x1,5 WD	707.2852.410.30	630	22x1.5	27.0	30.5	22.0	44.0	21.5	14.0	27	32	10.5	249
XESWV-20SM 27x2,0 WD	707.2852.506.30	420	27x2.0	33.0	37.0	26.5	49.0	24.0	16.0	32	41	16.0	405
XESWV-25SM 33x2,0 WD	707.2852.550.30	420	33x2.0	40.0	43.5	31.5	60.0	30.5	18.0	41	46	20.0	805
XESWV-30SM 42x2,0 WD	707.2852.600.30	420	42x2.0	50.0	50.5	37.0	74.0	35.5	20.0	50	55	26.0	1392
XESWV-38SM 48x2,0 WD	707.2852.954.30	420	48x2.0	56.0	57.5	41.5	84.0	40.5	22.0	55	65	32.0	2167

Dichtungsmaterial: FKM

Sealing material: FKM

Material de junta tórica: FKM

M	10x1.0	12/14x1.5	16x1.5	18x1.5	20x1.5	22x1.5	26x1.5	27x2.0	33x2.0	42x2.0	48x2.0
[Nm]	15	25	45	60	110	80	150	160	210	360	540

Anzugsdrehmoment für Hohlschraube in Nm

Tightening torque for hollow bolt in Nm

Pares de apriete para tornillo hueco en Nm

## Winkel-Schwenkverschraubungen

Abdichtung mit gekammertem FKM Weichdichtring

### Banjo elbow fittings

sealing with restraining seal ring FKM

### Racores orientables angulares

junta con anillo retentivo FKM blanda

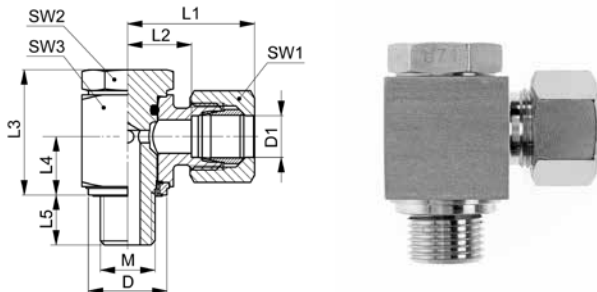

10

## ESWV-..LM WD / SM WD

Type-D1 M	Mat.-Nr.	PN	M	D	L1	L2	L3	L4	L5	SW1	SW2	SW3	g/Stk
M=metrisches Gewinde (zylindrisch)	M=metric thread (parallel)	M=rosca métrica (cilíndrica)											
ESWV-06LLM 10x1,0 WD	708.2852.180.10	100	10x1.0	15.0	21.5	10.0	21.0	10.0	8.0	12	14	15	42
ESWV-08LLM 10x1,0 WD	708.2852.230.10	100	10x1.0	15.0	22.5	11.0	21.0	10.0	8.0	14	14	15	45
ESWV-06LM 10x1,0 WD	708.2852.180.20	500	10x1.0	15.0	27.0	12.0	21.0	10.5	8.0	14	14	17	59
ESWV-08LM 12x1,5 WD	708.2852.240.20	500	12x1.5	19.0	29.5	14.5	30.0	14.0	12.0	17	19	22	90
ESWV-10LM 14x1,5 WD	708.2852.280.20	500	14x1.5	19.0	30.5	15.5	30.0	14.0	12.0	19	19	22	103
ESWV-12LM 16x1,5 WD	708.2852.330.20	500	16x1.5	22.0	33.0	18.0	34.5	16.5	12.0	22	22	27	158
ESWV-15LM 18x1,5 WD	708.2852.390.20	500	18x1.5	24.0	36.5	21.5	38.5	18.5	12.0	27	24	27	209
ESWV-18LM 22x1,5 WD	708.2852.460.20	500	22x1.5	27.0	37.5	21.0	44.0	21.5	14.0	32	27	32	320
ESWV-22LM 26x1,5 WD	708.2852.535.20	250	26x1.5	33.0	44.0	27.5	49.0	24.0	16.0	36	32	41	485
ESWV-28LM 33x2,0 WD	708.2852.570.20	250	33x2.0	40.0	48.5	32.0	60.0	30.5	18.0	41	41	46	882
ESWV-35LM 42x2,0 WD	708.2852.600.20	250	42x2.0	50.0	57.5	36.0	74.0	35.5	20.0	50	50	55	1508
ESWV-42LM 48x2,0 WD	708.2852.992.20	250	48x2.0	56.0	63.5	40.5	84.0	40.5	22.0	60	55	65	2341
ESWV-06SM 12x1,5 WD	708.2852.195.30	800	12x1.5	19.0	31.5	16.5	30.0	14.0	12.0	17	19	22	85
ESWV-08SM 14x1,5 WD	708.2852.245.30	800	14x1.5	19.0	31.5	16.5	30.0	14.0	12.0	19	19	22	103
ESWV-10SM 16x1,5 WD	708.2852.285.30	800	16x1.5	22.0	35.0	18.5	34.5	16.5	12.0	22	22	27	170
ESWV-12SM 18x1,5 WD	708.2852.333.30	800	18x1.5	24.0	36.5	20.0	38.5	18.5	12.0	24	24	27	220
ESWV-14SM 20x1,5 WD	708.2852.382.30	800	20x1.5	27.0	40.5	22.5	44.0	21.5	14.0	27	27	32	280
ESWV-16SM 22x1,5 WD	708.2852.410.30	630	22x1.5	27.0	40.5	22.0	44.0	21.5	14.0	30	27	32	320
ESWV-20SM 27x2,0 WD	708.2852.506.30	420	27x2.0	33.0	48.0	26.5	49.0	24.0	16.0	36	32	41	518
ESWV-25SM 33x2,0 WD	708.2852.550.30	420	33x2.0	40.0	55.5	31.5	60.0	30.5	18.0	46	41	46	1030
ESWV-30SM 42x2,0 WD	708.2852.600.30	420	42x2.0	50.0	63.5	37.0	74.0	35.5	20.0	50	50	55	1640
ESWV-38SM 48x2,0 WD	708.2852.954.30	420	48x2.0	56.0	72.5	41.5	84.0	40.5	22.0	60	55	65	2530

Baumaße sind Ungefährmaße bei angezogener Überwurfmutter.

Sizes are approximate dimensions at tightened nut.

Las medidas son aproximadas con la tuerca de unión apretada.

Dichtungsmaterial: FKM

Sealing material: FKM

Material de junta tórica: FKM

M	10x1.0	12/14x1.5	16x1.5	18x1.5	20x1.5	22x1.5	26x1.5	27x2.0	33x2.0	42x2.0	48x2.0
[Nm]	15	25	45	60	110	80	150	160	210	360	540

Anzugsdrehmoment für Hohlschraube in Nm      Tightening torque for hollow bolt in Nm      Pares de apriete para tornillo hueco en Nm

**Gerade Aufschraubstutzen**  
**Straight female adaptor connectors**  
**Cuerpos atornillables rectos**

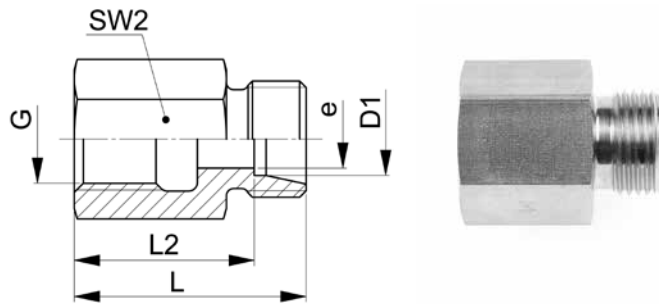

**XGAV-..LR**

Type-D1 G	Mat.-Nr.	PN	G	L	L2	SW2	e	g/Stk
G=Rohrgewinde (zylindrisch)		G=BSP thread (parallel)				G=rosca de conexión (cilíndrica)		
XGAV-06LR 1.8	706.1201.100.20	500	1/8	26.0	19.0	14	4.0	18
XGAV-06LR 1.4	706.1201.110.20	500	1/4	31.0	24.0	19	4.0	38
XGAV-08LR 1.4	706.1201.170.20	500	1/4	31.0	24.0	19	6.0	36
XGAV-08LR 3.8	706.1201.180.20	500	3/8	32.0	25.0	24	6.0	62
XGAV-08LR 1.2	706.1201.185.20	500	1/2	36.0	29.0	27	6.0	54
XGAV-10LR 1.4	706.1201.270.20	500	1/4	32.0	25.0	19	8.0	40
XGAV-10LR 3.8	706.1201.280.20	500	3/8	33.0	26.0	24	8.0	48
XGAV-10LR 1.2	706.1201.285.20	500	1/2	37.0	30.0	27	8.0	80
XGAV-12LR 1.4	706.1201.380.20	400	1/4	32.0	25.0	19	10.0	40
XGAV-12LR 3.8	706.1201.390.20	400	3/8	33.0	26.0	24	10.0	62
XGAV-12LR 1.2	706.1201.400.20	400	1/2	37.0	30.0	27	10.0	78
XGAV-15LR 3.8	706.1201.532.20	400	3/8	34.0	27.0	24	12.0	68
XGAV-15LR 1.2	706.1201.534.20	400	1/2	38.0	31.0	27	12.0	86
XGAV-18LR 3.8	706.1201.644.20	400	3/8	34.0	26.5	27	14.0	100
XGAV-18LR 1.2	706.1201.646.20	400	1/2	38.0	30.5	27	15.0	88
XGAV-22LR 3.4	706.1201.768.20	250	3/4	43.0	35.5	36	19.0	178
XGAV-28LR 1.1	706.1201.850.20	250	1	45.5	38.0	41	24.0	214
XGAV-35LR 5.4	706.1201.944.20	250	1 1/4	51.5	41.0	55	30.0	472
XGAV-42LR 3.2	706.1201.992.20	250	1 1/2	53.5	42.5	60	36.0	540

**Gerade Aufschraubverschraubungen**  
**Straight female adaptor fittings**  
**Racores atornillables rectos**

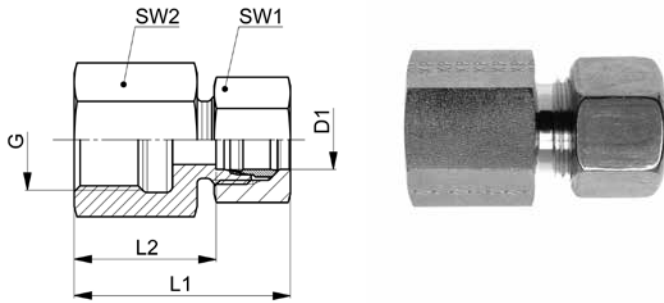

10

**GAV-..LR**

Type-D1 G	Mat.-Nr.	PN	G	L1	L2	SW1	SW2	g/Stk
G=Rohrgewinde (zylindrisch)		G=BSP thread (parallel)			G=rosca de conexión (cilíndrica)			
GAV-06LR 1.8	708.1201.100.20	500	1/8	34.0	19.0	14	14	27
GAV-06LR 1.4	708.1201.110.20	500	1/4	39.0	24.0	14	19	48
GAV-08LR 1.4	708.1201.170.20	500	1/4	39.0	24.0	17	19	50
GAV-08LR 3.8	708.1201.180.20	500	3/8	40.0	25.0	17	24	78
GAV-08LR 1.2	708.1201.185.20	500	1/2	44.0	29.0	17	27	84
GAV-10LR 1.4	708.1201.270.20	500	1/4	40.0	25.0	19	19	60
GAV-10LR 3.8	708.1201.280.20	500	3/8	41.0	26.0	19	24	68
GAV-10LR 1.2	708.1201.285.20	500	1/2	45.0	30.0	19	27	102
GAV-12LR 1.4	708.1201.380.20	400	1/4	40.0	25.0	22	19	68
GAV-12LR 3.8	708.1201.390.20	400	3/8	41.0	26.0	22	24	88
GAV-12LR 1.2	708.1201.400.20	400	1/2	45.0	30.0	22	27	106
GAV-15LR 3.8	708.1201.532.20	400	3/8	42.0	27.0	27	24	114
GAV-15LR 1.2	708.1201.534.20	400	1/2	46.0	31.0	27	27	113
GAV-18LR 3.8	708.1201.644.20	400	3/8	43.0	26.5	32	27	168
GAV-18LR 1.2	708.1201.646.20	400	1/2	47.0	30.5	32	27	151
GAV-22LR 3.4	708.1201.768.20	250	3/4	52.0	35.5	36	36	270
GAV-28LR 1.1	708.1201.850.20	250	1	55.0	38.0	41	41	311
GAV-35LR 5.4	708.1201.944.20	250	1 1/4	63.0	41.0	50	55	588
GAV-42LR 3.2	708.1201.992.20	250	1 1/2	66.0	42.5	60	60	760

Baumaße sind Ungefährmaße bei angezogener Überwurfmutter.

Sizes are approximate dimensions at tightened nut.

Las medidas son aproximadas con la tuerca de unión apretada.

**Gerade Aufschraubstutzen**  
**Straight female adaptor connectors**  
**Cuerpos atornillables rectos**

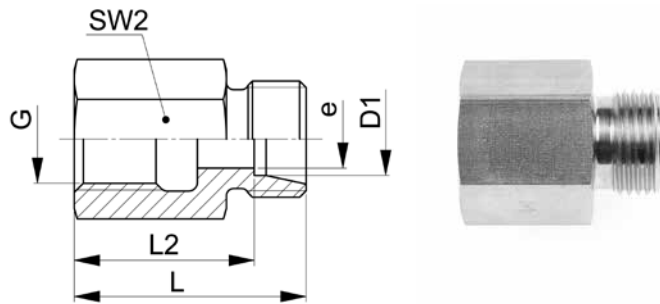

**XGAV-..SR**

Type-D1 G	Mat.-Nr.	PN	G	L	L2	SW2	e	g/Stk
G=Rohrgewinde (zylindrisch)		G=BSP thread (parallel)				G=rosca de conexión (cilíndrica)		
XGAV-06SR 1.8	706.1201.100.30	800	1/8	28.0	21.0	17	4.0	32
XGAV-06SR 1.4	706.1201.110.30	800	1/4	33.0	26.0	19	4.0	42
XGAV-08SR 1.4	706.1201.170.30	800	1/4	33.0	26.0	19	5.0	44
XGAV-10SR 1.4	706.1201.270.30	800	1/4	34.0	26.5	22	7.0	80
XGAV-10SR 3.8	706.1201.280.30	800	3/8	34.0	26.5	24	7.0	70
XGAV-12SR 1.4	706.1201.380.30	630	1/4	34.5	27.0	22	8.0	70
XGAV-12SR 3.8	706.1201.390.30	630	3/8	34.0	26.5	24	8.0	72
XGAV-12SR 1.2	706.1201.400.30	630	1/2	38.0	30.5	27	8.0	84
XGAV-14SR 1.2	706.1201.504.30	630	1/2	40.0	32.0	27	10.0	94
XGAV-16SR 1.2	706.1201.566.30	630	1/2	40.0	31.5	27	12.0	96
XGAV-20SR 3.8	706.1201.703.30	420	3/8	38.0	27.5	32	14.0	134
XGAV-20SR 1.2	706.1201.706.30	420	1/2	45.0	34.5	32	16.0	154
XGAV-20SR 3.4	706.1201.708.30	420	3/4	45.0	34.5	36	16.0	194
XGAV-25SR 1.1	706.1201.810.30	420	1	49.5	37.5	41	20.0	245
XGAV-30SR 5.4	706.1201.902.30	420	1 1/4	55.5	42.0	55	25.0	514
XGAV-38SR 3.2	706.1201.953.30	420	1 1/2	59.5	43.5	60	32.0	617

**Gerade Aufschraubverschraubungen**  
**Straight female adaptor fittings**  
**Racores atornillables rectos**

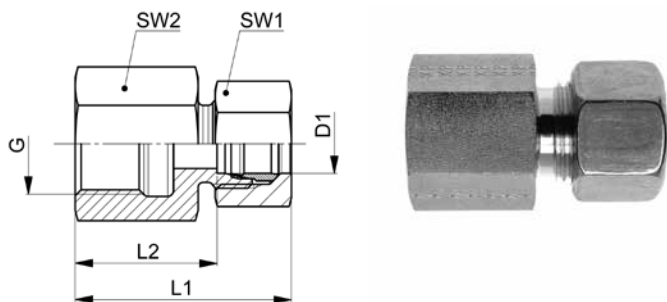

10

**GAV-..SR**

Type-D1 G	Mat.-Nr.	PN	G	L1	L2	SW1	SW2	g/Stk
G=Rohrgewinde (zylindrisch)		G=BSP thread (parallel)			G=rosca de conexión (cilíndrica)			
GAV-06SR 1.8	708.1201.100.30	800	1/8	36.0	21.0	17	17	50
GAV-06SR 1.4	708.1201.110.30	800	1/4	41.0	26.0	17	19	49
GAV-08SR 1.4	708.1201.170.30	800	1/4	41.0	26.0	19	19	59
GAV-10SR 1.4	708.1201.270.30	800	1/4	43.0	26.5	22	22	114
GAV-10SR 3.8	708.1201.280.30	800	3/8	43.0	26.5	22	24	100
GAV-12SR 1.4	708.1201.380.30	630	1/4	44.0	27.0	24	22	106
GAV-12SR 3.8	708.1201.390.30	630	3/8	43.0	26.5	24	24	112
GAV-12SR 1.2	708.1201.400.30	630	1/2	47.0	30.5	24	27	122
GAV-14SR 1.2	708.1201.504.30	630	1/2	50.0	32.0	27	27	148
GAV-16SR 1.2	708.1201.566.30	630	1/2	50.0	31.5	30	27	175
GAV-20SR 3.8	708.1201.703.30	420	3/8	51.0	27.5	36	32	245
GAV-20SR 1.2	708.1201.706.30	420	1/2	56.0	34.5	36	32	248
GAV-20SR 3.4	708.1201.708.30	420	3/4	56.0	34.5	36	36	300
GAV-25SR 1.1	708.1201.810.30	420	1	62.0	37.5	46	41	466
GAV-30SR 5.4	708.1201.902.30	420	1 1/4	69.0	42.0	50	55	719
GAV-38SR 3.2	708.1201.953.30	420	1 1/2	75.0	43.5	60	60	980

Baumaße sind Ungefährmaße bei angezogener Überwurfmutter.

Sizes are approximate dimensions at tightened nut.

Las medidas son aproximadas con la tuerca de unión apretada.

## Gerade Aufschraubstutzen

### Straight female adaptor connectors

### Cuerpos atornillables rectos

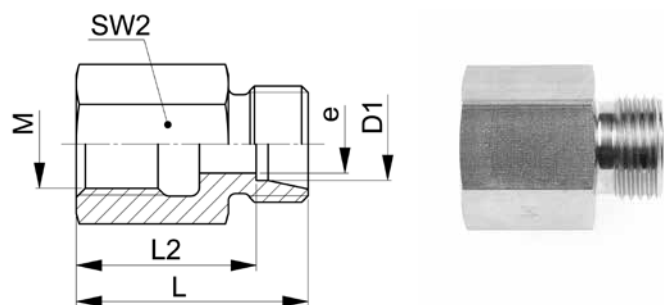

### XGAV-..LM/SM

Type-D1 M	Mat.-Nr.	PN	M	L	L2	SW2	e	g/Stk
M=metrisches Gewinde (zylindrisch)	M=metric thread (parallel)	M=rosca métrica (cilindrica)						
XGAV-06LM 10x1,0	706.1204.180.20	500	10x1.0	26.5	19.5	14	4.0	18
XGAV-08LM 12x1,5	706.1204.240.20	500	12x1.5	31.0	24.0	17	6.0	30
XGAV-10LM 14x1,5	706.1204.280.20	500	14x1.5	32.0	25.0	19	8.0	36
XGAV-12LM 16x1,5	706.1204.330.20	400	16x1.5	33.0	26.0	22	10.0	52
XGAV-12LM 18x1,5	706.1204.333.20	400	18x1.5	35.0	28.0	24	10.0	64
XGAV-12LM 20x1,5	706.1204.335.20	400	20x1.5	35.0	28.0	27	10.0	78
XGAV-15LM 18x1,5	706.1204.390.20	400	18x1.5	35.0	28.0	24	12.0	66
XGAV-18LM 22x1,5	706.1204.460.20	400	22x1.5	37.0	29.5	30	15.0	108
XGAV-22LM 26x1,5	706.1204.535.20	250	26x1.5	42.0	34.5	32	19.0	126
XGAV-28LM 33x2,0	706.1204.570.20	250	33x2.0	45.0	37.5	41	24.0	221
XGAV-35LM 42x2,0	706.1204.600.20	250	42x2.0	51.0	40.5	55	30.0	461
XGAV-42LM 48x2,0	706.1204.992.20	250	48x2.0	53.0	42.0	60	36.0	539
XGAV-06SM 12x1,5	706.1204.190.30	800	12x1.5	33.0	26.0	17	4.0	34
XGAV-08SM 14x1,5	706.1204.198.30	800	14x1.5	33.0	26.0	19	5.0	42
XGAV-10SM 16x1,5	706.1204.285.30	800	16x1.5	34.0	26.5	22	7.0	56
XGAV-12SM 18x1,5	706.1204.333.30	630	18x1.5	35.0	27.5	24	8.0	70
XGAV-12SM 20x1,5	706.1204.335.30	630	20x1.5	37.0	29.5	27	8.0	90
XGAV-14SM 20x1,5	706.1204.382.30	630	20x1.5	39.0	41.0	27	10.0	94
XGAV-16SM 22x1,5	706.1204.410.30	630	22x1.5	39.0	30.5	30	12.0	116
XGAV-20SM 27x2,0	706.1204.506.30	420	27x2.0	45.0	34.5	36	16.0	196
XGAV-25SM 33x2,0	706.1204.550.30	420	33x2.0	49.0	37.0	41	20.0	248

**Gerade Aufschraubverschraubungen**  
**Straight female adaptor fittings**  
**Racores atornillables rectos**

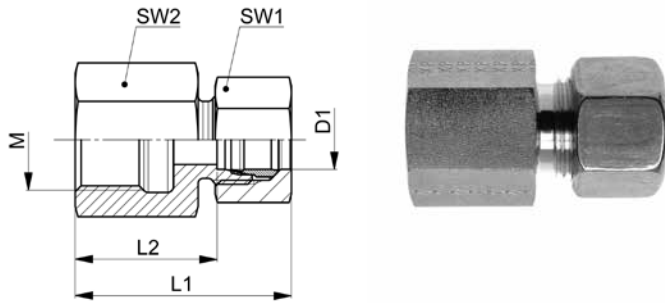

10

**GAV-..LM/SM**

Type-D1 M	Mat.-Nr.	PN	M	L1	L2	SW1	SW2	g/Stk
M=metrisches Gewinde (zylindrisch)	M=metric thread (parallel)	M=rosca métrica (cilindrica)						
GAV-06LM 10x1,0	708.1204.180.20	500	10x1.0	34.5	19.5	14	14	26
GAV-08LM 12x1,5	708.1204.240.20	500	12x1.5	39.0	24.0	17	17	50
GAV-10LM 14x1,5	708.1204.280.20	500	14x1.5	40.0	25.0	19	19	50
GAV-12LM 16x1,5	708.1204.330.20	400	16x1.5	41.0	26.0	22	22	90
GAV-12LM 18x1,5	708.1204.333.20	400	18x1.5	43.0	28.0	22	24	95
GAV-12LM 20x1,5	708.1204.335.20	400	20x1.5	43.0	28.0	22	27	110
GAV-15LM 18x1,5	708.1204.390.20	400	18x1.5	43.0	28.0	27	24	115
GAV-18LM 22x1,5	708.1204.460.20	400	22x1.5	46.0	29.5	32	30	157
GAV-22LM 26x1,5	708.1204.535.20	250	26x1.5	51.0	34.5	36	32	215
GAV-28LM 33x2,0	708.1204.570.20	250	33x2.0	54.0	37.5	41	41	320
GAV-35LM 42x2,0	708.1204.600.20	250	42x2.0	62.0	40.5	50	55	620
GAV-42LM 48x2,0	708.1204.992.20	250	48x2.0	65.0	42.0	60	60	780
GAV-06SM 12x1,5	708.1204.190.30	800	12x1.5	41.0	26.0	17	17	54
GAV-08SM 14x1,5	708.1204.198.30	800	14x1.5	41.0	26.0	19	19	69
GAV-10SM 16x1,5	708.1204.285.30	800	16x1.5	43.0	26.5	22	22	102
GAV-12SM 18x1,5	708.1204.333.30	630	18x1.5	44.0	27.5	24	24	110
GAV-12SM 20x1,5	708.1204.335.30	630	20x1.5	46.0	29.5	24	27	125
GAV-14SM 20x1,5	708.1204.382.30	630	20x1.5	49.0	31.0	27	27	148
GAV-16SM 22x1,5	708.1204.410.30	630	22x1.5	49.0	30.5	30	30	175
GAV-20SM 27x2,0	708.1204.506.30	420	27x2.0	56.0	34.5	36	36	307
GAV-25SM 33x2,0	708.1204.550.30	420	33x2.0	61.0	37.0	46	41	466

Baumaße sind Ungefährmaße bei angezogener Überwurfmutter.

Sizes are approximate dimensions at tightened nut.

Las medidas son aproximadas con la tuerca de unión apretada.

**Manometer-Anschlussstutzen**

Abdichtung mit metallischem Dichtkantenring

**Manometer connectors**

sealing with metal seal-edge ring

**Cuerpos para manómetro**

junta con anillo con borde de obturación metálico

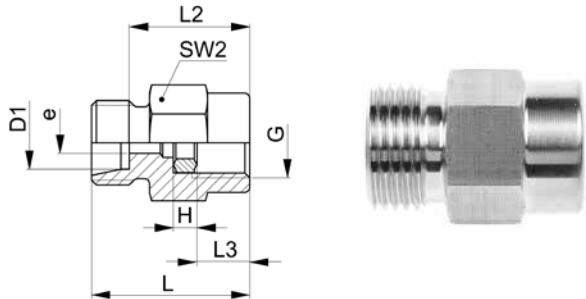

**XMAV-..LR/SR DKR**

Type-D1 G	Mat.-Nr.	PN	G	H	L	L2	L3	SW2	e	g/Stk
G=Rohrgewinde (zylindrisch)		G=BSP thread (parallel)			G=rosca de conexión (cilíndrica)					
XMAV-06LR 1.4 DKR	707.0230.110.20	500	1/4	4.5	29.0	22.0	10.0	19	4.0	37
XMAV-08LR 1.4 DKR	707.0230.170.20	500	1/4	4.5	29.0	22.0	10.0	19	4.0	37
XMAV-10LR 1.4 DKR	707.0230.270.20	500	1/4	4.5	30.0	23.0	10.0	19	4.0	41
XMAV-12LR 1.4 DKR	707.0230.380.20	400	1/4	4.5	30.0	23.0	10.0	19	4.0	42
XMAV-12LR 1.2 DKR	707.0230.400.20	400	1/2	5.0	37.0	30.0	15.0	27	7.0	90
XMAV-06SR 1.2 DKR	707.0230.125.30	800	1/2	5.0	38.0	31.0	15.0	27	4.0	89
XMAV-08SR 1.2 DKR	707.0230.185.30	800	1/2	5.0	38.0	31.0	15.0	27	5.0	92
XMAV-10SR 1.2 DKR	707.0230.285.30	800	1/2	5.0	38.0	30.5	15.0	27	7.0	96
XMAV-12SR 1.2 DKR	707.0230.400.30	630	1/2	5.0	38.0	30.5	15.0	27	7.0	98
XMAV-14SR 1.2 DKR	707.0230.504.30	630	1/2	5.0	40.0	32.0	15.0	27	7.0	104

**Manometer-Anschlussverschraubungen**

Abdichtung mit metallischem Dichtkantenring

**Manometer fittings**

sealing with metal seal-edge ring

**Racores para manómetro**

junta con anillo con borde de obturación metálico

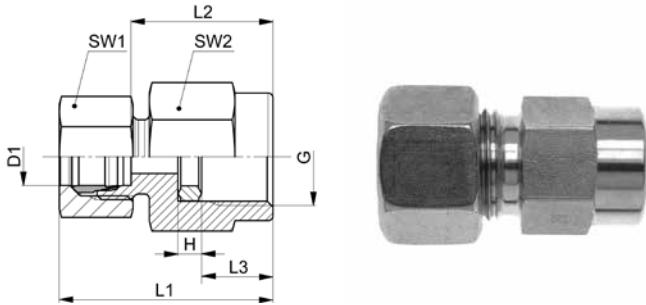

10

**MAV-..LR/SR**

Type-D1 G	Mat.-Nr.	PN	G	H	L1	L2	L3	SW1	SW2	g/Stk
G=Rohrgewinde (zylindrisch)		G=BSP thread (parallel)				G=rosca de conexión (cilíndrica)				
MAV-06LR 1.4	708.0230.110.20	500	1/4	4.5	37.0	22.0	10.0	14	19	46
MAV-08LR 1.4	708.0230.170.20	500	1/4	4.5	37.0	22.0	10.0	17	19	53
MAV-10LR 1.4	708.0230.270.20	500	1/4	4.5	38.0	23.0	10.0	19	19	62
MAV-12LR 1.4	708.0230.380.20	400	1/4	4.5	38.0	23.0	10.0	22	19	65
MAV-12LR 1.2	708.0230.400.20	400	1/2	5.0	45.0	30.0	15.0	22	27	105
MAV-06SR 1.2	708.0230.125.30	800	1/2	5.0	46.0	31.0	15.0	17	27	110
MAV-08SR 1.2	708.0230.185.30	800	1/2	5.0	46.0	31.0	15.0	19	27	115
MAV-10SR 1.2	708.0230.285.30	800	1/2	5.0	47.0	30.5	15.0	22	27	120
MAV-12SR 1.2	708.0230.400.30	630	1/2	5.0	47.0	30.5	15.0	24	27	136
MAV-14SR 1.2	708.0230.504.30	630	1/2	5.0	50.0	32.0	15.0	27	27	158

Baumaße sind Ungefährmaße bei angezogener Überwurfmutter.

Sizes are approximate dimensions at tightened nut.

Las medidas son aproximadas con la tuerca de unión apretada.

**Manometer-Anschlussstutzen NPT**

**Manometer connectors NPT**

**Cuerpos para manómetro NPT**

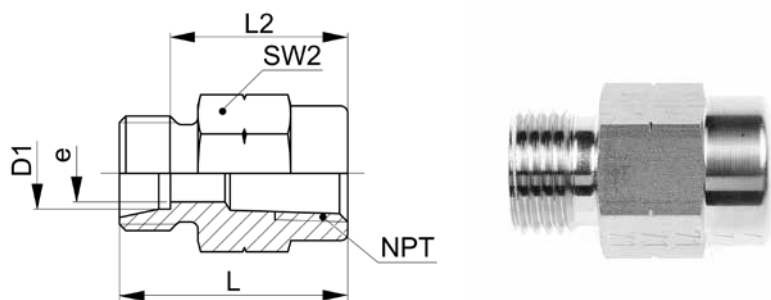

**XMAV-..LNPT/SNPT**

Type -D1 NPT	Mat.-Nr.	PN	NPT	L	L2	SW2	e	g/Stk
NPT=Einschraubgewinde NPT		NPT=tapered male adaptor thread NPT			NPT=rosca de conexión cónica NPT			
XMAV-06LNPT 1.4	706.0231.110.20	500	1/4	30.0	23.0	19	4.0	39
XMAV-06LNPT 1.2	706.0231.125.20	500	1/2	38.0	31.0	27	4.0	93
XMAV-08LNPT 1.4	706.0231.170.20	500	1/4	30.0	23.0	19	6.0	40
XMAV-08LNPT 1.2	706.0231.185.20	500	1/2	38.0	31.0	27	6.0	94
XMAV-10LNPT 1.4	706.0231.270.20	500	1/4	32.0	25.0	19	8.0	44
XMAV-10LNPT 1.2	706.0231.285.20	500	1/2	39.0	32.0	27	8.0	96
XMAV-12LNPT 1.4	706.0231.380.20	400	1/4	32.0	25.0	19	10.0	45
XMAV-12LNPT 1.2	706.0231.400.20	400	1/2	39.0	32.0	27	10.0	97
XMAV-06SNPT 1.2	706.0231.125.30	800	1/2	40.0	33.0	27	4.0	98
XMAV-08SNPT 1.2	706.0231.185.30	800	1/2	40.0	33.0	27	5.0	100
XMAV-12SNPT 1.2	706.0231.400.30	630	1/2	40.0	32.5	27	8.0	105

**Manometer-Anschlussverschraubungen NPT**

**Manometer fittings NPT**

**Racores para manómetro NPT**

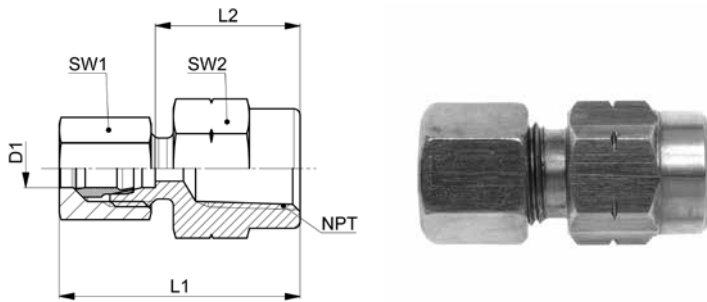

10

**MAV-..LNPT/SNPT**

Type-D1 NPT	Mat.-Nr.	PN	NPT	L1	L2	SW1	SW2	g/Stk
NPT=Einschraubgewinde NPT		NPT=tapered male adaptor thread NPT			NPT=rosca de conexión cónica NPT			
MAV-06LNPT 1.4	708.0231.110.20	500	1/4	38.0	23.0	14	19	50
MAV-06LNPT 1.2	708.0231.125.20	500	1/2	46.0	31.0	14	27	104
MAV-08LNPT 1.4	708.0231.170.20	500	1/4	38.0	23.0	17	19	56
MAV-08LNPT 1.2	708.0231.185.20	500	1/2	46.0	31.0	17	27	110
MAV-10LNPT 1.4	708.0231.270.20	500	1/4	40.0	25.0	19	19	65
MAV-10LNPT 1.2	708.0231.285.20	500	1/2	47.0	32.0	19	27	117
MAV-12LNPT 1.4	708.0231.380.20	400	1/4	40.0	25.0	22	19	73
MAV-12LNPT 1.2	708.0231.400.20	400	1/2	47.0	32.0	22	27	125
MAV-06SNPT 1.2	708.0231.125.30	800	1/2	48.0	33.0	17	27	117
MAV-08SNPT 1.2	708.0231.185.30	800	1/2	48.0	33.0	19	27	122
MAV-12SNPT 1.2	708.0231.400.30	630	1/2	49.0	32.5	24	27	142

Baumaße sind Ungefährmaße bei angezogener Überwurfmutter.

Sizes are approximate dimensions at tightened nut.

Las medidas son aproximadas con la tuerca de unión apretada.

## Einstellbare Manometerverschraubungen mit Dichtkegel und O-Ring

Abdichtung mit metallischem Dichtkantenring

## Adjustable manometer fittings with taper and O-ring

sealing with metal seal-edge ring

## Racores para manómetro ajustables con junta cónica y junta tórica

junta con anillo con borde de obturación metálico

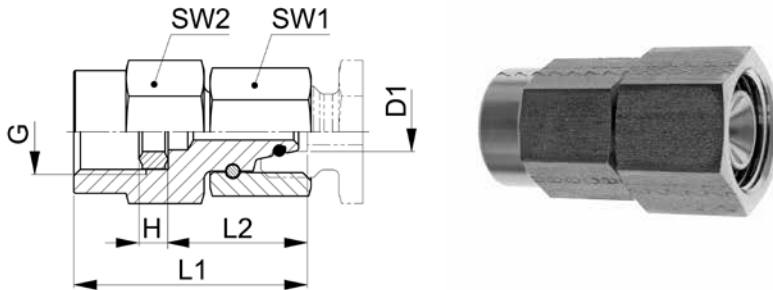

10

### EMAKO-..LR/SR

Type-D1 G	Mat.-Nr.	PN	G	H	L1	L2	SW1	SW2	g/Stk
G=Rohrgewinde (zylindrisch)		G=BSP thread (parallel)				G=rosca de conexión (cilíndrica)			
EMAKO-06LR 1.4	708.0245.110.20	315	1/4	4.5	35.5	21.5	14	19	45
EMAKO-08LR 1.4	708.0245.170.20	315	1/4	4.5	35.5	21.5	17	19	57
EMAKO-10LR 1.4	708.0245.270.20	315	1/4	4.5	36.0	21.5	19	19	63
EMAKO-12LR 1.4	708.0245.380.20	315	1/4	4.5	36.0	21.5	22	19	75
EMAKO-06SR 1.4	708.0245.110.30	630	1/4	4.5	36.0	21.5	17	19	54
EMAKO-06SR 1.2	708.0245.125.30	630	1/2	5.0	42.5	23.0	17	27	110
EMAKO-08SR 1.4	708.0245.170.30	630	1/4	4.5	37.5	23.0	19	19	62
EMAKO-08SR 1.2	708.0245.185.30	630	1/2	5.0	43.0	23.5	19	27	112
EMAKO-10SR 1.4	708.0245.270.30	630	1/4	4.5	37.5	27.5	22	19	76
EMAKO-10SR 1.2	708.0245.285.30	630	1/2	5.0	43.5	24.0	22	27	123
EMAKO-12SR 1.4	708.0245.380.30	630	1/4	4.5	39.5	25.0	24	19	120
EMAKO-12SR 1.2	708.0245.400.30	630	1/2	5.0	45.0	25.5	24	27	139

Baumaße sind Ungefährmaße bei angezogener Überwurfmutter.

Sizes are approximate dimensions at tightened nut.

Las medidas son aproximadas con la tuerca de unión apretada.

Dichtungsmaterial: FKM

Sealing material: FKM

Material de junta tórica: FKM.

**Einstellbare Manometer-Anschlussstutzen**

Abdichtung mit metallischem Dichtkantenring

**Adjustable manometer connectors**

sealing with metal seal-edge ring

**Cuerpos para manómetro ajustables**

junta con anillo con borde de obturación metálico

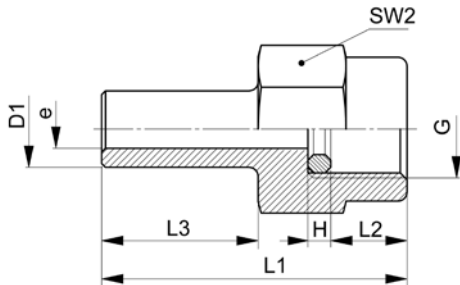

**XEMAS-..LR/SR DKR**

Type-D1 G	Mat.-Nr.	PN	G	H	L1	L2	L3	SW2	e	g/Stk
G=Rohrgewinde (zylindrisch)		G=BSP thread (parallel)			G=rosca de conexión (cilíndrica)					
XEMAS-06LR 1.4 DKR	707.0235.110.20	500	1/4	4.5	38.0	8.5	18.5	19	3.5	37
XEMAS-08LR 1.4 DKR	707.0235.170.20	500	1/4	4.5	38.0	8.5	19.5	19	5.0	36
XEMAS-10LR 1.4 DKR	707.0235.270.20	500	1/4	4.5	40.0	8.5	20.5	19	5.0	43
XEMAS-12LR 1.4 DKR	707.0235.380.20	400	1/4	4.5	40.0	8.5	20.5	19	5.0	49
XEMAS-06SR 1.2 DKR	707.0235.125.30	800	1/2	5.0	48.0	15.0	18.5	27	3.5	100
XEMAS-08SR 1.2 DKR	707.0235.185.30	800	1/2	5.0	50.0	15.0	20.5	27	4.5	102
XEMAS-10SR 1.2 DKR	707.0235.285.30	800	1/2	5.0	50.0	15.0	21.5	27	6.5	103
XEMAS-12SR 1.2 DKR	707.0235.400.30	630	1/2	5.0	47.5	15.0	22.5	27	7.5	92

**Einstellbare Manometer-Anschlussstutzen vormontiert**

Abdichtung mit metallischem Dichtkantenring

**Adjustable manometer fittings pre-assembled**

sealing with metal seal-edge ring

**Racores para manómetro ajustables premontado**

junta con anillo con borde de obturación metálico

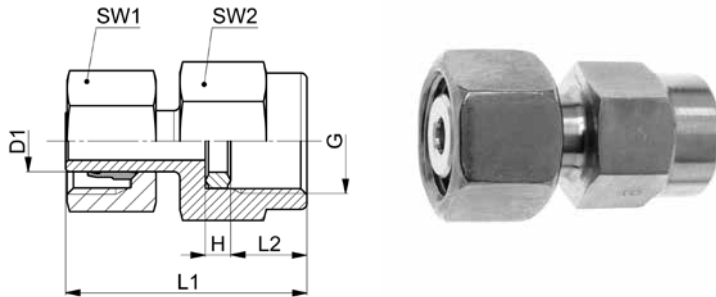

10

**EMAS-..LR/SR**

Type-D1 G	Mat.-Nr.	PN	G	H	L1	L2	SW1	SW2	g/Stk
G=Rohrgewinde (zylindrisch)		G=BSP thread (parallel)				G=rosca de conexión (cilíndrica)			
EMAS-06LR 1.4	708.0235.110.20	500	1/4	4.5	38.0	8.5	14	19	46
EMAS-08LR 1.4	708.0235.170.20	500	1/4	4.5	38.0	8.5	17	19	53
EMAS-10LR 1.4	708.0235.270.20	500	1/4	4.5	40.0	8.5	19	19	62
EMAS-12LR 1.4	708.0235.380.20	400	1/4	4.5	40.0	8.5	22	19	70
EMAS-06SR 1.2	708.0235.125.30	800	1/2	5.0	48.0	15.0	17	27	105
EMAS-08SR 1.2	708.0235.185.30	800	1/2	5.0	50.0	15.0	19	27	107
EMAS-10SR 1.2	708.0235.285.30	800	1/2	5.0	50.0	15.0	22	27	125
EMAS-12SR 1.2	708.0235.400.30	630	1/2	5.0	47.5	15.0	24	27	134

Baumaße sind Ungefährmaße bei angezogener Überwurfmutter.

Sizes are approximate dimensions at tightened nut.

Las medidas son aproximadas con la tuerca de unión apretada.

Achtung: Endmontage des vormontierten Schaftes wird erst nach 1/4 Umdrehung der Überwurfmutter über den Punkt des deutlich fühlbaren Kraftanstiegs erreicht.

Attention: Final standpipe assembly, the nut will be tightened at least by 1/4 of a turn beyond the point of a noticeable increase in force.

Atención: El montaje del vástago premontado se completa girando 1/4 vuelta la tuerca de unión a partir del punto en que aumenta claramente la resistencia.

**Einstellbare Manometer-Anschlussstutzen NPT**  
**Adjustable manometer connectors NPT**  
**Cuerpos para manómetro ajustables NPT**

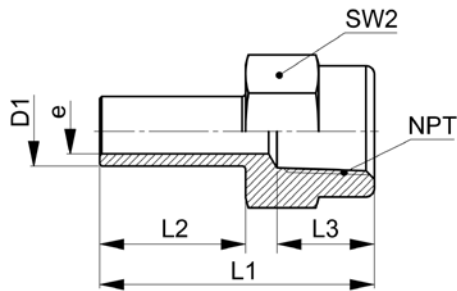

**XEMAS-..LNPT/SNPT**

Type -D1 NPT	Mat.-Nr.	PN	NPT	L1	L2	L3	SW2	e	g/Stk
NPT=Einschraubgewinde NPT		NPT=tapered male adaptor thread NPT			NPT=rosca de conexión cónica NPT				
XEMAS-06LNPT 1.4	706.0236.110.20	500	1/4	38.0	19.5	14.0	19	3.2	35
XEMAS-08LNPT 1.4	706.0236.170.20	500	1/4	38.0	21.0	14.0	19	5.0	33
XEMAS-10LNPT 1.4	706.0236.270.20	500	1/4	39.5	21.0	14.0	19	6.5	39
XEMAS-12LNPT 1.4	706.0236.380.20	400	1/4	40.5	21.0	14.0	19	8.0	44
XEMAS-06SNPT 1.2	706.0236.125.30	800	1/2	45.0	20.0	18.0	27	3.2	85
XEMAS-08SNPT 1.2	706.0236.185.30	800	1/2	46.0	21.0	18.0	27	4.0	88
XEMAS-10SNPT 1.2	706.0236.285.30	800	1/2	47.0	22.0	18.0	27	6.0	90
XEMAS-12SNPT 1.2	706.0236.400.30	630	1/2	47.5	22.5	18.0	27	7.0	94

**Einstellbare Manometer-Anschlussstutzen NPT vormontiert**  
**Adjustable manometer fittings NPT pre-assembled**  
**Racores para manómetro ajustables NPT premontado**

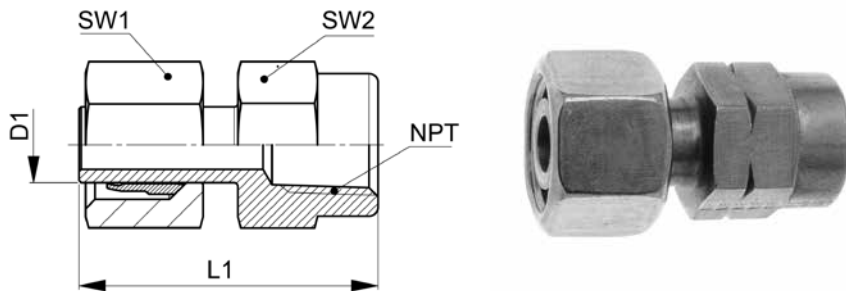

10

**EMAS-..LNPT/SNPT**

Type-D1 NPT	Mat.-Nr.	PN	NPT	L1	SW1	SW2	g/Stk
NPT=Einschraubgewinde NPT		NPT=tapered male adaptor thread NPT			NPT=rosca de conexión cónica NPT		
EMAS-06LNPT 1.4	708.0236.110.20	500	1/4	38.0	14	19	48
EMAS-08LNPT 1.4	708.0236.170.20	500	1/4	38.0	17	19	54
EMAS-10LNPT 1.4	708.0236.270.20	500	1/4	39.5	19	19	62
EMAS-12LNPT 1.4	708.0236.380.20	400	1/4	40.5	22	19	76
EMAS-06SNPT 1.2	708.0236.125.30	800	1/2	45.0	17	27	104
EMAS-08SNPT 1.2	708.0236.185.30	800	1/2	46.0	19	27	110
EMAS-10SNPT 1.2	708.0236.285.30	800	1/2	47.0	22	27	123
EMAS-12SNPT 1.2	708.0236.400.30	630	1/2	47.5	24	27	132

Baumaße sind Ungefährmaße bei angezogener Überwurfmutter.

Achtung: Endmontage des vormontierten Schaftes wird erst nach 1/4 Umdrehung der Überwurfmutter über den Punkt des deutlich fühlbaren Kraftanstiegs erreicht.

Sizes are approximate dimensions at tightened nut.

Attention: Final standpipe assembly, the nut will be tightened at least by 1/4 of a turn beyond the point of a noticeable increase in force.

Las medidas son aproximadas con la tuerca de unión apretada.

Atención: El montaje del vástago premontado se completa girando 1/4 vuelta la tuerca de unión a partir del punto en que aumenta claramente la resistencia.

**Gerade Messstutzen**

mit Schraubkupplung M16x2 und O-Ring

**Straight connectors with test gauge**

with threaded connection M16x2 and O-ring

**Cuerpos de medición rectos**

con acoplamiento roscado M16x2 y junta tórica

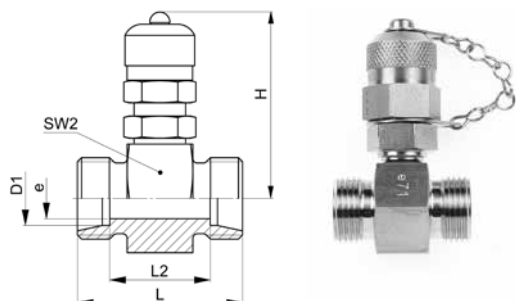

**XEMV-GV-..L/S**

Type-D1	Mat.-Nr.	PN	H	L	L2	SW2	e	g/Stk
XEMV-GV06L	707.0240.060.20	315	49.0	34.5	20.0	24	4.0	125
XEMV-GV08L	707.0240.080.20	315	49.0	34.5	20.0	24	4.0	127
XEMV-GV10L	707.0240.100.20	315	49.0	36.5	22.0	24	7.0	131
XEMV-GV12L	707.0240.120.20	315	49.0	36.5	22.0	24	9.0	132
XEMV-GV15L	707.0240.150.20	315	52.0	38.5	24.0	30	12.0	171
XEMV-GV18L	707.0240.180.20	315	53.0	38.5	23.0	32	15.0	189
XEMV-GV22L	707.0240.220.20	160	55.0	42.5	27.0	36	19.0	222
XEMV-GV28L	707.0240.280.20	160	57.0	42.5	27.0	41	23.0	269
XEMV-GV35L	707.0240.350.20	160	57.0	46.5	25.0	50	30.0	377
XEMV-GV42L	707.0240.420.20	160	64.0	46.5	24.0	55	36.0	421
XEMV-GV06S	707.0240.060.30	630	49.0	38.5	24.0	24	4.0	136
XEMV-GV08S	707.0240.080.30	630	49.0	38.5	24.0	24	5.0	140
XEMV-GV10S	707.0240.100.30	630	49.0	38.5	23.0	24	7.0	143
XEMV-GV12S	707.0240.120.30	630	49.0	38.5	23.0	24	8.0	149
XEMV-GV14S	707.0240.140.30	630	50.0	42.5	26.0	27	9.0	176
XEMV-GV16S	707.0240.160.30	420	52.0	42.5	25.0	30	12.0	191
XEMV-GV20S	707.0240.200.30	420	55.0	46.5	25.0	36	16.0	256
XEMV-GV25S	707.0240.250.30	420	57.0	50.5	26.0	41	20.0	334
XEMV-GV30S	707.0240.300.30	420	60.0	54.5	27.0	46	25.0	421
XEMV-GV38S	707.0240.380.30	420	64.0	61.0	28.5	55	32.0	637

O-Ring-Dichtung am Einschraubgewinde  
Dichtungsmaterial: FKM

O-ring-seal on male adaptor thread  
Sealing material: FKM

junta tórica en la rosca  
Material de junta tórica: FKM.

**Gerade Messverschraubungen**

mit Schraubkupplung M16x2 und O-Ring, Kegelausführung

**Straight fittings with test gauge**

with threaded connection M16x2 and O-ring, tapered version

**Racores de medición rectos**

con acoplamiento roscado M16x2 y junta tórica, versión cónico

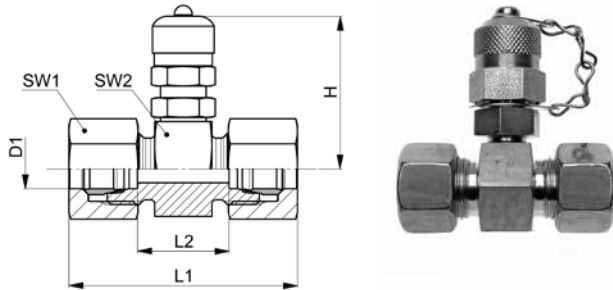

10

**EMV-GV-..L/S**

Type-D1	Mat.-Nr.	PN	H	L1	L2	SW1	SW2	g/Stk
EMV-GV-06L	708.0240.060.20	315	49.0	50.5	20.0	14	24	149
EMV-GV-08L	708.0240.080.20	315	49.0	50.5	20.0	17	24	161
EMV-GV-10L	708.0240.100.20	315	49.0	52.5	22.0	19	24	175
EMV-GV-12L	708.0240.120.20	315	49.0	52.5	22.0	22	24	186
EMV-GV-15L	708.0240.150.20	315	52.0	54.5	24.0	27	30	261
EMV-GV-18L	708.0240.180.20	315	53.0	56.5	23.0	32	32	323
EMV-GV-22L	708.0240.220.20	160	55.0	60.5	27.0	36	36	396
EMV-GV-28L	708.0240.280.20	160	57.0	60.5	27.0	41	41	477
EMV-GV-35L	708.0240.350.20	160	60.0	63.5	25.0	50	50	695
EMV-GV-42L	708.0240.420.20	160	64.0	70.5	24.0	60	55	903
EMV-GV-06S	708.0240.060.30	630	49.0	54.5	24.0	17	24	172
EMV-GV-08S	708.0240.080.30	630	49.0	54.5	24.0	19	24	182
EMV-GV-10S	708.0240.100.30	630	49.0	56.5	23.0	22	24	207
EMV-GV-12S	708.0240.120.30	630	49.0	56.5	23.0	24	24	223
EMV-GV-14S	708.0240.140.30	630	50.0	62.5	26.0	27	27	284
EMV-GV-16S	708.0240.160.30	420	52.0	62.5	25.0	30	30	327
EMV-GV-20S	708.0240.200.30	420	55.0	68.5	25.0	36	36	478
EMV-GV-25S	708.0240.250.30	420	57.0	74.5	26.0	46	41	776
EMV-GV-30S	708.0240.300.30	420	60.0	80.5	27.0	50	46	907
EMV-GV-38S	708.0240.380.30	420	64.0	91.0	28.5	60	55	1347

Baumaße sind Ungefährmaße bei angezogener Überwurfmutter.

O-Ring-Dichtung am Einschraubgewinde  
Dichtungsmaterial: FKM

Sizes are approximate dimensions at tightened nut.

O-ring-seal on male adaptor thread  
Sealing material: FKM

Las medidas son aproximadas con la tuerca de unión apretada.

junta tórica en la rosca  
Material de junta tórica: FKM

**Messanschlüsse**

mit Schraubkupplung M16x2, Kegelausführung

**Test point gauges**

with threaded connection M16x2, tapered version

**Conexiones de medición**

con acoplamiento roscado M16x2, versión cónico

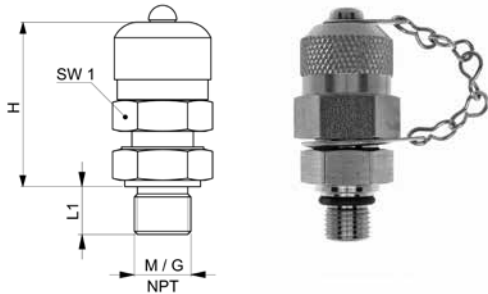

**EMV-..**

Type -M	Mat.-Nr.	PN	M	H	L1	SW1	g/Stk
M=metrisches Gewinde (zylindrisch)		M=metric thread (parallel)			M=rosca métrica (cilindrica)		
EMV-M 10x1,0	706.0246.150.30	630	10x1.0	28.0	10.0	17	66

mit O-Ring-Dichtung am Einschraubgewinde  
Dichtungsmaterial: FKM

with O-ring-seal on male adaptor thread  
Sealing material: FKM

con junta tórica en la rosca  
Material de junta tórica: FKM.

Type -NPT	Mat.-Nr.	PN	NPT	H	L1	SW1	g/Stk
NPT=Einschraubgewinde NPT		NPT=tapered male adaptor thread NPT			NPT=rosca de conexión cónica NPT		
EMV-NPT1.8	706.0247.020.30	630	1/8	24.5	9.5	17	70
EMV-NPT1.4	706.0247.040.30	630	1/4	20.0	14.0	17	70

Type -G	Mat.-Nr.	PN	G	H	L1	SW1	g/Stk
G=Rohrgewinde (zylindrisch)		G=BSP thread (parallel)			G=rosca de conexión (cilindrica)		
EMV-G1.4A-WD	706.0249.040.30	630	1/4	25.0	12.0	19	70

Dichtungsmaterial: FKM

Sealing material: FKM

Material de junta tórica: FKM.

**Messanschlüsse für 24° Konen**

mit Schraubkupplung M16x2 und O-Ring, Kegelausführung

**Test point gauges for 24° taper**

with threaded connection M16x2 and O-ring, tapered version

**Conexiones de medición para conos de 24°**

con acoplamiento roscado M16x2 y junta tórica, versión cónico

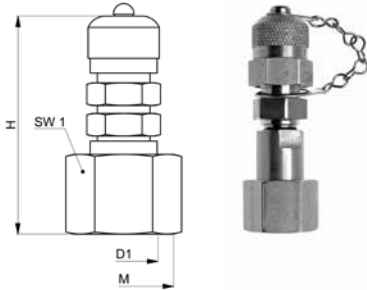

10

**EMV-..L/S**

Type-D1	Mat.-Nr.	PN	M	H	SW1	g/Stk
M=metrisches Gewinde (zylindrisch)	M=metric thread (parallel)	M=rosca métrica (cilindrica)				
▼ EMV-06L	708.0243.060.20	500	12x1.5	64.0	14	114
▼ EMV-08L	708.0243.080.20	500	14x1.5	64.0	17	116
▼ EMV-10L	708.0243.100.20	500	16x1.5	65.0	19	127
▼ EMV-12L	708.0243.120.20	400	18x1.5	65.0	22	144
EMV-15L	708.0243.150.20	400	22x1.5	52.0	27	130
EMV-18L	708.0243.180.20	400	26x1.5	55.0	32	161
EMV-22L	708.0243.220.20	250	30x2.0	55.0	36	202
EMV-28L	708.0243.280.20	250	36x2.0	55.0	41	261
EMV-35L	708.0243.350.20	250	45x2.0	57.0	50	394
EMV-42L	708.0243.420.20	250	52x2.0	57.0	60	570
▼ EMV-06S	708.0243.060.30	630	14x1.5	64.0	17	116
▼ EMV-08S	708.0243.080.30	630	16x1.5	65.0	19	128
▼ EMV-10S	708.0243.100.30	630	18x1.5	65.0	22	144
▼ EMV-12S	708.0243.120.30	630	20x1.5	68.0	24	162
▼ EMV-14S	708.0243.140.30	630	22x1.5	52.0	27	135
EMV-16S	708.0243.160.30	630	24x1.5	52.0	30	158
EMV-20S	708.0243.200.30	420	30x2.0	57.0	36	227
EMV-25S	708.0243.250.30	420	36x2.0	58.0	46	375
EMV-30S	708.0243.300.30	420	42x2.0	60.0	50	447
EMV-38S	708.0243.380.30	420	52x2.0	62.0	60	683

mit O-Ring-Dichtung am Einschraubgewinde  
Dichtungsmaterial: FKM

with O-ring-seal on male adaptor thread  
Sealing material: FKM

con junta tórica en la rosca  
Material de junta tórica: FKM.

**Reduzierstutzen mit Dichtkegel und O-Ring**

dichtkegelseitig vormontiert

**Reducing connectors with taper and O-ring**

pre-assembled on tapered nipple side

**Cuerpos de reducción con junta cónica y junta tórica**

premontado en lado de junta cónica

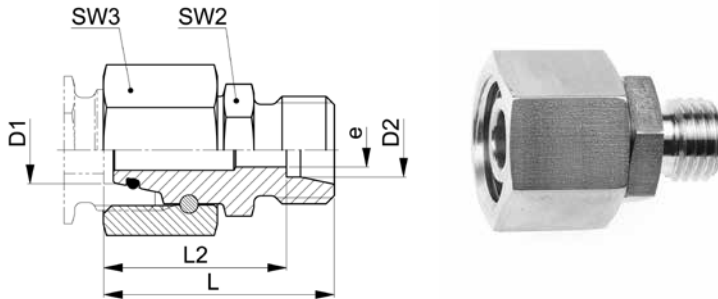

**XGRKO-..L M**

Type-D1 /D2	Mat.-Nr.	PN	L	L2	SW2	SW3	e	g/Stk
XGRKO-08/06L M	707.1871.140.20	315	30.5	23.5	12	17	4.0	30
XGRKO-10/06L M	707.1871.175.20	315	32.0	25.0	14	19	4.0	42
XGRKO-10/08L M	707.1871.190.20	315	32.0	25.0	14	19	6.0	40
XGRKO-12/06L M	707.1871.215.20	315	32.0	25.0	17	22	4.0	56
XGRKO-12/08L M	707.1871.225.20	315	32.0	25.0	17	22	6.0	56
XGRKO-12/10L M	707.1871.240.20	315	33.0	26.0	17	22	8.0	52
XGRKO-15/06L M	707.1871.391.20	315	35.5	28.5	22	27	4.0	88
XGRKO-15/08L M	707.1871.400.20	315	35.5	28.5	22	27	6.0	100
XGRKO-15/10L M	707.1871.410.20	315	36.0	29.0	22	27	8.0	96
XGRKO-15/12L M	707.1871.420.20	315	36.0	29.0	22	27	10.0	94
XGRKO-18/06L M	707.1871.563.20	315	35.0	28.0	24	32	4.0	112
XGRKO-18/08L M	707.1871.570.20	315	35.0	28.0	24	32	6.0	116
XGRKO-18/10L M	707.1871.575.20	315	36.0	29.0	24	32	8.0	128
XGRKO-18/12L M	707.1871.580.20	315	36.0	29.0	24	32	10.0	124
XGRKO-18/15L M	707.1871.610.20	315	37.0	30.0	24	32	12.0	126
XGRKO-22/06L M	707.1871.723.20	160	39.0	32.0	27	36	4.0	166
XGRKO-22/08L M	707.1871.724.20	160	39.0	32.0	27	36	6.0	164
XGRKO-22/10L M	707.1871.725.20	160	40.0	33.0	27	36	8.0	166
XGRKO-22/12L M	707.1871.730.20	160	40.0	33.0	27	36	10.0	166
XGRKO-22/15L M	707.1871.745.20	160	41.0	34.0	27	36	12.0	190
XGRKO-22/18L M	707.1871.755.20	160	41.0	33.5	27	36	15.0	180
XGRKO-28/06L M	707.1871.828.20	160	41.0	34.0	36	41	4.0	310
XGRKO-28/08L M	707.1871.829.20	160	41.0	34.0	36	41	6.0	306
XGRKO-28/10L M	707.1871.830.20	160	42.0	35.0	36	41	8.0	300
XGRKO-28/12L M	707.1871.835.20	160	42.0	35.0	36	41	10.0	300
XGRKO-28/15L M	707.1871.865.20	160	43.0	36.0	36	41	12.0	304
XGRKO-28/18L M	707.1871.870.20	160	43.0	35.5	36	41	15.0	306
XGRKO-28/22L M	707.1871.900.20	160	45.0	37.5	36	41	19.0	332

Fortsetzung auf nächster linker Seite

To be continued on next left page

Continuación próxima página izquierda

**Reduzierschraubungen mit Dichtkegel und O-Ring**  
**Reducing fittings with taper and O-ring**  
**Racores de reducción con junta cónica y junta tórica**

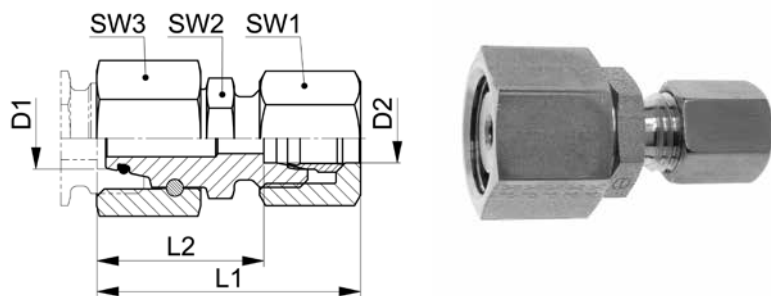

10

**GRKO-..L**

Type-D1 /D2	Mat.-Nr.	PN	L1	L2	SW1	SW2	SW3	g/Stk
GRKO-08/06L	708.1870.140.20	315	38.5	23.5	14	12	17	42
GRKO-10/06L	708.1870.175.20	315	40.0	25.0	14	14	19	54
GRKO-10/08L	708.1870.190.20	315	40.0	25.0	17	14	19	56
GRKO-12/06L	708.1870.215.20	315	40.0	25.0	14	17	22	68
GRKO-12/08L	708.1870.225.20	315	40.0	25.0	17	17	22	72
GRKO-12/10L	708.1870.240.20	315	41.0	26.0	19	17	22	74
GRKO-15/06L	708.1870.391.20	315	43.5	28.5	14	22	27	100
GRKO-15/08L	708.1870.400.20	315	43.5	28.5	17	22	27	118
GRKO-15/10L	708.1870.410.20	315	44.0	29.0	19	22	27	118
GRKO-15/12L	708.1870.420.20	315	44.0	29.0	22	22	27	122
GRKO-18/06L	708.1870.563.20	315	43.0	28.0	14	24	32	122
GRKO-18/08L	708.1870.570.20	315	43.0	28.0	17	24	32	132
GRKO-18/10L	708.1870.575.20	315	44.0	29.0	19	24	32	150
GRKO-18/12L	708.1870.580.20	315	44.0	29.0	22	24	32	152
GRKO-18/15L	708.1870.610.20	315	45.0	30.0	27	24	32	170
GRKO-22/06L	708.1870.723.20	160	47.0	32.0	14	27	36	178
GRKO-22/08L	708.1870.724.20	160	47.0	32.0	17	27	36	180
GRKO-22/10L	708.1870.725.20	160	48.0	33.0	19	27	36	186
GRKO-22/12L	708.1870.730.20	160	48.0	33.0	22	27	36	194
GRKO-22/15L	708.1870.745.20	160	49.0	34.0	27	27	36	236
GRKO-22/18L	708.1870.755.20	160	50.0	33.5	32	27	36	250
GRKO-28/06L	708.1870.828.20	160	49.0	34.0	14	36	46	322
GRKO-28/08L	708.1870.829.20	160	49.0	34.0	17	36	46	315
GRKO-28/10L	708.1870.830.20	160	50.0	35.0	19	36	46	320
GRKO-28/12L	708.1870.835.20	160	50.0	35.0	22	36	46	328
GRKO-28/15L	708.1870.865.20	160	51.0	36.0	27	36	46	350
GRKO-28/18L	708.1870.870.20	160	52.0	35.5	32	36	46	376
GRKO-28/22L	708.1870.900.20	160	54.0	37.5	36	36	46	420

Fortsetzung auf nächster rechter Seite

To be continued on next right page

Continuación próxima página derecha

**Reduzierstutzen mit Dichtkegel und O-Ring**

dichtkegelseitig vormontiert

**Reducing connectors with taper and O-ring**

pre-assembled on tapered nipple side

**Cuerpos de reducción con junta cónica y junta tórica**

premontado en lado de junta cónica

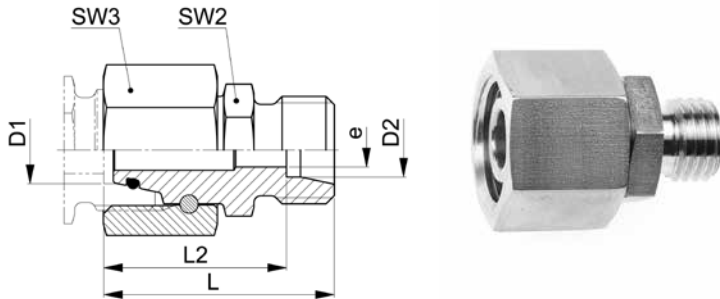

**XGRKO-..L M**

Type-D1 /D2	Mat.-Nr.	PN	L	L2	SW2	SW3	e	g/Stk
XGRKO-35/06L M	707.1871.951.20	160	44.0	37.0	46	50	4.0	349
XGRKO-35/08L M	707.1871.952.20	160	44.0	37.0	46	50	6.0	352
XGRKO-35/10L M	707.1871.953.20	160	45.0	38.0	46	50	8.0	355
XGRKO-35/12L M	707.1871.954.20	160	45.0	38.0	46	50	10.0	350
XGRKO-35/15L M	707.1871.946.20	160	46.0	39.0	46	50	12.0	358
XGRKO-35/18L M	707.1871.947.20	160	46.0	38.5	46	50	15.0	364
XGRKO-35/22L M	707.1871.948.20	160	48.0	40.5	46	50	19.0	362
XGRKO-35/28L M	707.1871.949.20	160	48.0	40.5	46	50	24.0	394
XGRKO-42/06L M	707.1871.986.20	160	47.5	40.5	50	60	4.0	536
XGRKO-42/08L M	707.1871.987.20	160	47.5	40.5	50	60	6.0	542
XGRKO-42/10L M	707.1871.988.20	160	48.5	41.5	50	60	8.0	548
XGRKO-42/12L M	707.1871.989.20	160	48.5	41.5	50	60	10.0	552
XGRKO-42/15L M	707.1871.991.20	160	49.5	42.5	50	60	12.0	554
XGRKO-42/18L M	707.1871.992.20	160	49.5	42.0	50	60	15.0	560
XGRKO-42/22L M	707.1871.993.20	160	51.5	44.0	50	60	19.0	528
XGRKO-42/28L M	707.1871.994.20	160	51.5	44.0	50	60	24.0	528
XGRKO-42/35L M	707.1871.996.20	160	53.5	43.0	50	60	30.0	592

Dichtungsmaterial: FKM

Sealing material: FKM

Material de junta tórica: FKM

**ISO 8434-1-RDSW**

**Reduzierschraubungen mit Dichtkegel und O-Ring**  
**Reducing fittings with taper and O-ring**  
**Racores de reducción con junta cónica y junta tórica**

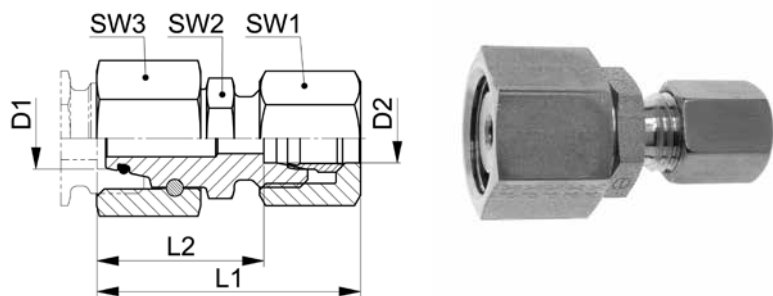

10

**GRKO-..L**

Type -D1 /D2	Mat.-Nr.	PN	L1	L2	SW1	SW2	SW3	g/Stk
GRKO-35/06L	708.1870.951.20	160	52.0	37.0	14	46	50	372
GRKO-35/08L	708.1870.952.20	160	52.0	37.0	17	46	50	388
GRKO-35/10L	708.1870.953.20	160	53.0	38.0	19	46	50	362
GRKO-35/12L	708.1870.954.20	160	53.0	38.0	22	46	50	378
GRKO-35/15L	708.1870.946.20	160	54.0	39.0	27	46	50	404
GRKO-35/18L	708.1870.947.20	160	55.0	38.5	32	46	50	432
GRKO-35/22L	708.1870.948.20	160	57.0	40.5	36	46	50	454
GRKO-35/28L	708.1870.949.20	160	57.0	40.5	41	46	50	504
GRKO-42/06L	708.1870.986.20	160	55.5	40.5	14	50	60	552
GRKO-42/08L	708.1870.987.20	160	55.5	40.5	17	50	60	558
GRKO-42/10L	708.1870.988.20	160	56.5	41.5	19	50	60	570
GRKO-42/12L	708.1870.989.20	160	56.5	41.5	22	50	60	582
GRKO-42/15L	708.1870.991.20	160	57.5	42.5	27	50	60	600
GRKO-42/18L	708.1870.992.20	160	58.5	42.0	32	50	60	628
GRKO-42/22L	708.1870.993.20	160	60.5	44.0	36	50	60	618
GRKO-42/28L	708.1870.994.20	160	60.5	44.0	41	50	60	636
GRKO-42/35L	708.1870.996.20	160	64.5	43.0	50	50	60	756

Baumaße sind Ungefährmaße bei angezogener Überwurfmutter.

Sizes are approximate dimensions at tightened nut.

Las medidas son aproximadas con la tuerca de unión apretada.

Dichtungsmaterial: FKM

Sealing material: FKM

Material de junta tórica: FKM

**ISO 8434-1-RDSWC**

## Reduzierstutzen mit Dichtkegel und O-Ring

dichtkegelseitig vormontiert

## Reducing connectors with taper and O-ring

pre-assembled on tapered nipple side

## Cuerpos de reducción con junta cónica y junta tórica

premontado en lado de junta cónica

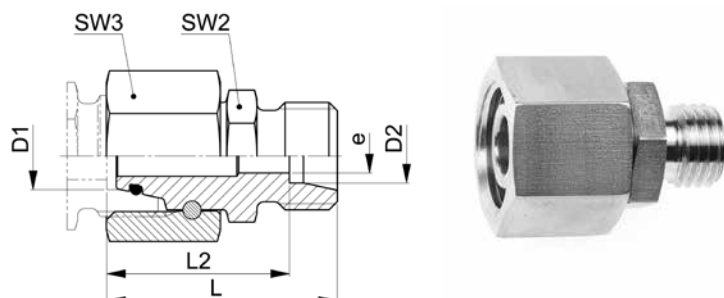

### XGRKO-..S M

Type-D1 /D2	Mat.-Nr.	PN	L	L2	SW2	SW3	e	g/Stk
XGRKO-08/06S M	707.1871.140.30	630	34.0	27.0	14	19	4.0	46
XGRKO-10/06S M	707.1871.175.30	630	34.5	27.5	17	22	4.0	60
XGRKO-10/08S M	707.1871.190.30	630	34.5	27.5	17	22	5.0	62
XGRKO-12/06S M	707.1871.215.30	630	37.0	30.0	19	24	4.0	79
XGRKO-12/08S M	707.1871.225.30	630	37.0	30.0	19	24	5.0	80
XGRKO-12/10S M	707.1871.240.30	630	37.0	29.5	19	24	7.0	78
XGRKO-14/06S M	707.1871.296.30	630	38.5	31.5	22	27	4.0	114
XGRKO-14/08S M	707.1871.300.30	630	38.5	31.5	22	27	5.0	114
XGRKO-14/10S M	707.1871.320.30	630	38.5	31.0	22	27	7.0	110
XGRKO-14/12S M	707.1871.340.30	630	38.5	31.0	22	27	8.0	112
XGRKO-16/06S M	707.1871.466.30	400	39.0	32.0	22	30	4.0	110
XGRKO-16/08S M	707.1871.468.30	400	39.0	32.0	22	30	5.0	112
XGRKO-16/10S M	707.1871.470.30	400	39.0	31.5	22	30	7.0	121
XGRKO-16/12S M	707.1871.480.30	400	39.0	31.5	22	30	8.0	124
XGRKO-16/14S M	707.1871.500.30	400	41.0	33.0	22	30	10.0	128
XGRKO-20/06S M	707.1871.650.30	400	43.0	36.0	27	36	4.0	188
XGRKO-20/08S M	707.1871.655.30	400	43.0	36.0	27	36	5.0	176
XGRKO-20/10S M	707.1871.660.30	400	43.0	35.5	27	36	7.0	178
XGRKO-20/12S M	707.1871.665.30	400	43.0	35.5	27	36	8.0	200
XGRKO-20/14S M	707.1871.675.30	400	45.0	37.0	27	36	10.0	202
XGRKO-20/16S M	707.1871.685.30	400	45.0	36.5	27	36	12.0	294
XGRKO-25/06S M	707.1871.788.30	400	45.5	38.5	36	46	4.0	338
XGRKO-25/08S M	707.1871.787.30	400	45.5	38.5	36	46	5.0	340
XGRKO-25/10S M	707.1871.789.30	400	45.5	38.0	36	46	7.0	318
XGRKO-25/12S M	707.1871.791.30	400	45.5	38.0	36	46	8.0	320
XGRKO-25/14S M	707.1871.790.30	400	47.5	39.5	36	46	10.0	322
XGRKO-25/16S M	707.1871.800.30	400	47.5	39.0	36	46	12.0	324
XGRKO-25/20S M	707.1871.820.30	400	49.5	39.0	36	46	16.0	346

Fortsetzung auf nächster linker Seite

To be continued on next left page

Continuación próxima página izquierda

**Reduzierschraubungen mit Dichtkegel und O-Ring**  
**Reducing fittings with taper and O-ring**  
**Racores de reducción con junta cónica y junta tórica**

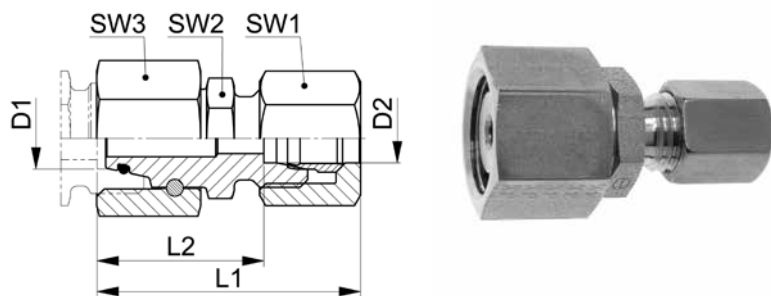

10

**GRKO-..S**

Type-D1 /D2	Mat.-Nr.	PN	L1	L2	SW1	SW2	SW3	g/Stk
GRKO-08/06S	708.1870.140.30	630	42.0	27.0	17	14	19	64
GRKO-10/06S	708.1870.175.30	630	43.5	27.5	17	17	22	78
GRKO-10/08S	708.1870.190.30	630	42.5	27.5	19	17	22	82
GRKO-12/06S	708.1870.215.30	630	45.0	30.0	17	19	24	98
GRKO-12/08S	708.1870.225.30	630	45.0	30.0	19	19	24	100
GRKO-12/10S	708.1870.240.30	630	46.0	29.5	22	19	24	112
GRKO-14/06S	708.1870.296.30	630	46.5	31.5	17	22	27	132
GRKO-14/08S	708.1870.300.30	630	46.5	31.5	19	22	27	136
GRKO-14/10S	708.1870.320.30	630	47.5	31.0	22	22	27	146
GRKO-14/12S	708.1870.340.30	630	47.5	31.0	24	22	27	148
GRKO-16/06S	708.1870.466.30	400	47.0	32.0	17	22	30	128
GRKO-16/08S	708.1870.468.30	400	47.0	32.0	19	22	30	134
GRKO-16/10S	708.1870.470.30	400	48.0	31.5	22	22	30	156
GRKO-16/12S	708.1870.480.30	400	48.0	31.5	24	22	30	160
GRKO-16/14S	708.1870.500.30	400	51.0	33.0	27	22	30	184
GRKO-20/06S	708.1870.650.30	400	51.0	36.0	17	27	36	206
GRKO-20/08S	708.1870.655.30	400	51.0	36.0	19	27	36	198
GRKO-20/10S	708.1870.660.30	400	52.0	35.5	22	27	36	210
GRKO-20/12S	708.1870.665.30	400	52.0	35.5	24	27	36	238
GRKO-20/14S	708.1870.675.30	400	55.0	37.0	27	27	36	258
GRKO-20/16S	708.1870.685.30	400	55.0	36.5	30	27	36	264
GRKO-25/06S	708.1870.788.30	400	53.5	38.5	17	36	46	356
GRKO-25/08S	708.1870.787.30	400	53.5	38.5	19	36	46	362
GRKO-25/10S	708.1870.789.30	400	54.5	38.0	22	36	46	352
GRKO-25/12S	708.1870.791.30	400	54.5	38.0	24	36	46	356
GRKO-25/14S	708.1870.790.30	400	57.5	39.5	27	36	46	374
GRKO-25/16S	708.1870.800.30	400	57.5	39.0	30	36	46	394
GRKO-25/20S	708.1870.820.30	400	60.5	39.0	36	36	46	458

Fortsetzung auf nächster rechter Seite

To be continued on next right page

Continuación próxima página derecha

**Reduzierstutzen mit Dichtkegel und O-Ring**

dichtkegelseitig vormontiert

**Reducing connectors with taper and O-ring**

pre-assembled on tapered nipple side

**Cuerpos de reducción con junta cónica y junta tórica**

premontado en lado de junta cónica

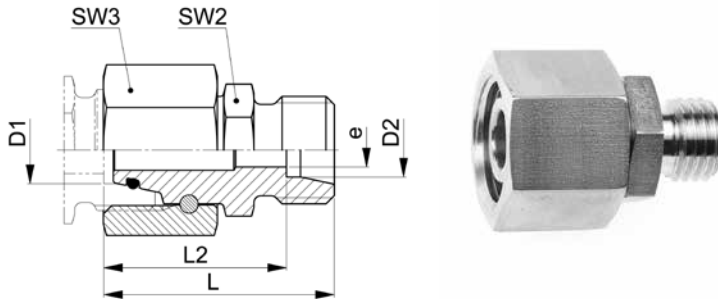

**XGRKO-..S M**

Type-D1 /D2	Mat.-Nr.	PN	L	L2	SW2	SW3	e	g/Stk
XGRKO-30/06S M	707.1871.937.30	400	51.0	44.0	41	50	4.0	378
XGRKO-30/08S M	707.1871.936.30	400	51.0	44.0	41	50	5.0	384
XGRKO-30/10S M	707.1871.939.30	400	51.0	43.5	41	50	7.0	390
XGRKO-30/12S M	707.1871.940.30	400	51.0	43.5	41	50	8.0	396
XGRKO-30/14S M	707.1871.941.30	400	53.0	45.0	41	50	10.0	424
XGRKO-30/16S M	707.1871.942.30	400	53.0	44.5	41	50	12.0	398
XGRKO-30/20S M	707.1871.943.30	400	55.0	44.5	41	50	16.0	418
XGRKO-30/25S M	707.1871.945.30	400	57.0	45.0	41	50	20.0	446
XGRKO-38/06S M	707.1871.965.30	315	54.5	47.5	50	60	4.0	550
XGRKO-38/08S M	707.1871.966.30	315	54.5	47.5	50	60	5.0	552
XGRKO-38/10S M	707.1871.967.30	315	54.5	47.0	50	60	7.0	555
XGRKO-38/12S M	707.1871.968.30	315	54.5	47.0	50	60	8.0	556
XGRKO-38/14S M	707.1871.969.30	315	56.5	48.5	50	60	10.0	600
XGRKO-38/16S M	707.1871.970.30	315	56.5	48.0	50	60	12.0	602
XGRKO-38/20S M	707.1871.971.30	315	58.5	48.0	50	60	16.0	570
XGRKO-38/25S M	707.1871.972.30	315	60.5	48.5	50	60	20.0	592
XGRKO-38/30S M	707.1871.975.30	315	62.5	49.0	50	60	25.0	662

Dichtungsmaterial: FKM

Sealing material: FKM

Material de junta tórica: FKM

**ISO 8434-1-RDSW**

**Reduzierschraubungen mit Dichtkegel und O-Ring**  
**Reducing fittings with taper and O-ring**  
**Racores de reducción con junta cónica y junta tórica**

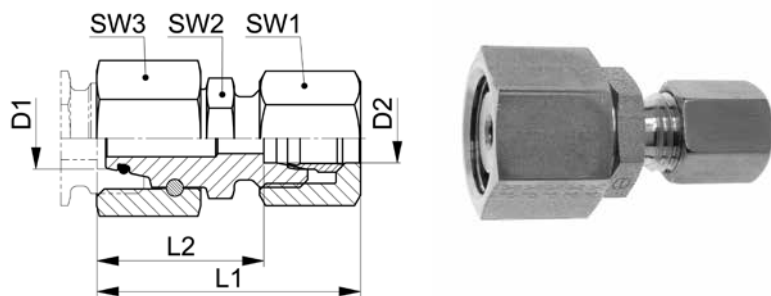

10

**GRKO-..S**

Type -D1 /D2	Mat.-Nr.	PN	L1	L2	SW1	SW2	SW3	g/Stk
GRKO-30/06S	708.1870.937.30	400	59.0	44.0	17	41	50	412
GRKO-30/08S	708.1870.936.30	400	59.0	44.0	19	41	50	416
GRKO-30/10S	708.1870.939.30	400	60.0	43.5	22	41	50	424
GRKO-30/12S	708.1870.940.30	400	60.0	43.5	24	41	50	432
GRKO-30/14S	708.1870.941.30	400	63.0	45.0	27	41	50	480
GRKO-30/16S	708.1870.942.30	400	63.0	44.5	30	41	50	468
GRKO-30/20S	708.1870.943.30	400	66.0	44.5	36	41	50	528
GRKO-30/25S	708.1870.945.30	400	69.0	45.0	46	41	50	672
GRKO-38/06S	708.1870.965.30	315	62.0	47.5	17	50	60	574
GRKO-38/08S	708.1870.966.30	315	62.0	47.5	19	50	60	578
GRKO-38/10S	708.1870.967.30	315	63.0	47.0	22	50	60	632
GRKO-38/12S	708.1870.968.30	315	63.0	47.0	24	50	60	638
GRKO-38/14S	708.1870.969.30	315	66.0	48.5	27	50	60	652
GRKO-38/16S	708.1870.970.30	315	66.0	48.0	30	50	60	672
GRKO-38/20S	708.1870.971.30	315	69.0	48.0	36	50	60	682
GRKO-38/25S	708.1870.972.30	315	72.0	48.5	46	50	60	818
GRKO-38/30S	708.1870.975.30	315	75.0	49.0	50	50	60	914

Baumaße sind Ungefährmaße bei angezogener Überwurfmutter.

Sizes are approximate dimensions at tightened nut.

Las medidas son aproximadas con la tuerca de unión apretada.

Dichtungsmaterial: FKM

Sealing material: FKM

Material de junta tórica: FKM

**ISO 8434-1-RDSWC**

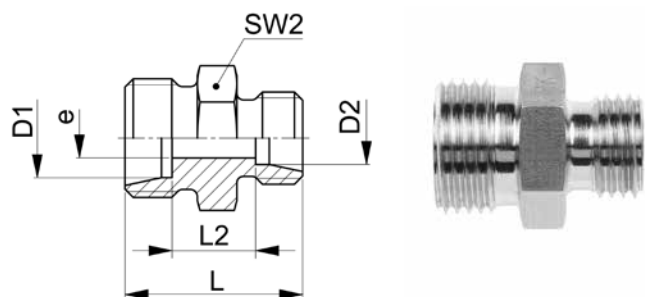
**Gerade Reduzierstutzen**
**Reducing connectors**
**Cuerpos de reducción rectos**

**XGR-.L**

Type-D1 / D2	Mat.-Nr.	PN	L	L2	SW2	e	g/Stk
XGR-06/04LL	706.1024.100.10	100	20.0	10.0	11	3.0	8
XGR-08/06LL	706.1024.140.10	100	22.0	11.0	12	4.0	12
XGR-08/06L	706.1024.140.20	500	25.0	11.0	14	4.0	19
XGR-10/06L	706.1024.175.20	500	26.0	12.0	17	4.0	25
XGR-10/08L	706.1024.190.20	500	26.0	12.0	17	6.0	25
XGR-12/06L	706.1024.215.20	400	27.0	13.0	19	4.0	32
XGR-12/08L	706.1024.225.20	400	27.0	13.0	19	6.0	32
XGR-12/10L	706.1024.240.20	400	28.0	14.0	19	8.0	33
XGR-15/06L	706.1024.391.20	400	28.0	14.0	24	4.0	51
XGR-15/08L	706.1024.400.20	400	28.0	14.0	24	6.0	51
XGR-15/10L	706.1024.410.20	400	29.0	15.0	24	8.0	51
XGR-15/12L	706.1024.420.20	400	29.0	15.0	24	10.0	50
XGR-18/08L	706.1024.570.20	400	29.0	14.0	27	6.0	70
XGR-18/10L	706.1024.575.20	400	30.0	15.0	27	8.0	70
XGR-18/12L	706.1024.580.20	400	30.0	15.0	27	10.0	70
XGR-18/15L	706.1024.610.20	400	31.0	16.0	27	12.0	74
XGR-22/10L	706.1024.725.20	250	32.0	17.0	32	8.0	101
XGR-22/12L	706.1024.730.20	250	32.0	17.0	32	10.0	100
XGR-22/15L	706.1024.745.20	250	33.0	18.0	32	12.0	104
XGR-22/18L	706.1024.755.20	250	33.0	18.0	32	15.0	104
XGR-28/10L	706.1024.830.20	250	33.0	18.0	41	8.0	163
XGR-28/12L	706.1024.835.20	250	33.0	18.0	41	10.0	161
XGR-28/15L	706.1024.865.20	250	34.0	19.0	41	12.0	165
XGR-28/18L	706.1024.870.20	250	34.0	19.0	41	15.0	164
XGR-28/22L	706.1024.900.20	250	36.0	21.0	41	19.0	161
XGR-35/15L	706.1024.946.20	250	37.0	19.0	46	12.0	243
XGR-35/18L	706.1024.947.20	250	37.0	19.0	46	15.0	242
XGR-35/22L	706.1024.948.20	250	39.0	21.0	46	19.0	239
XGR-35/28L	706.1024.949.20	250	39.0	21.0	46	24.0	230
XGR-42/15L	706.1024.991.20	250	39.0	21.0	55	12.0	363
XGR-42/18L	706.1024.992.20	250	39.0	20.0	55	15.0	362
XGR-42/22L	706.1024.993.20	250	41.0	22.0	55	19.0	358
XGR-42/28L	706.1024.994.20	250	41.0	22.0	55	24.0	346
XGR-42/35L	706.1024.996.20	250	43.0	21.0	55	30.0	347

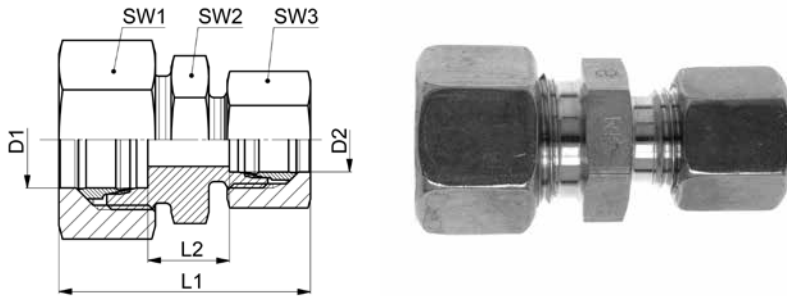
**Gerade Reduzierschraubungen**  
**Straight reducing fittings**  
**Racores de reducción rectos**



10

**GR..L**

Type-D1 / D2	Mat.-Nr.	PN	L1	L2	SW1	SW2	SW3	g/Stk
GR-06/04LL	708.1024.110.10	100	32.0	10.0	12	11	10	20
GR-08/06LL	708.1024.140.10	100	34.0	11.0	14	12	12	26
GR-08/06L	708.1024.140.20	500	41.0	11.0	17	14	14	51
GR-10/06L	708.1024.175.20	500	42.0	12.0	19	17	14	58
GR-10/08L	708.1024.190.20	500	42.0	12.0	19	17	17	58
GR-12/06L	708.1024.215.20	400	43.0	13.0	22	19	14	63
GR-12/08L	708.1024.225.20	400	43.0	13.0	22	19	17	70
GR-12/10L	708.1024.240.20	400	44.0	14.0	22	19	19	80
GR-15/06L	708.1024.391.20	400	44.0	14.0	27	24	14	100
GR-15/08L	708.1024.400.20	400	44.0	14.0	27	24	17	105
GR-15/10L	708.1024.410.20	400	45.0	15.0	27	24	19	110
GR-15/12L	708.1024.420.20	400	45.0	15.0	27	24	22	132
GR-18/08L	708.1024.570.20	400	46.0	14.0	32	27	17	115
GR-18/10L	708.1024.575.20	400	47.0	15.0	32	27	19	145
GR-18/12L	708.1024.580.20	400	47.0	15.0	32	27	22	175
GR-18/15L	708.1024.610.20	400	48.0	16.0	32	27	27	175
GR-22/10L	708.1024.725.20	250	49.0	17.0	36	32	19	198
GR-22/12L	708.1024.730.20	250	49.0	17.0	36	32	22	200
GR-22/15L	708.1024.745.20	250	50.0	18.0	36	32	27	220
GR-22/18L	708.1024.755.20	250	51.0	18.0	36	32	32	274
GR-28/10L	708.1024.830.20	250	50.0	18.0	41	41	19	250
GR-28/12L	708.1024.835.20	250	50.0	18.0	41	41	22	270
GR-28/15L	708.1024.865.20	250	51.0	19.0	41	41	27	296
GR-28/18L	708.1024.870.20	250	52.0	19.0	41	41	32	307
GR-28/22L	708.1024.900.20	250	54.0	21.0	41	41	36	309
GR-35/15L	708.1024.946.20	250	56.0	19.0	50	46	27	390
GR-35/18L	708.1024.947.20	250	57.0	19.0	50	46	32	410
GR-35/22L	708.1024.948.20	250	59.0	21.0	50	46	36	434
GR-35/28L	708.1024.949.20	250	59.0	21.0	50	46	41	455
GR-42/15L	708.1024.991.20	250	59.0	21.0	60	55	27	550
GR-42/18L	708.1024.992.20	250	60.0	20.0	60	55	32	590
GR-42/22L	708.1024.993.20	250	62.0	22.0	60	55	36	610
GR-42/28L	708.1024.994.20	250	62.0	22.0	60	55	41	650
GR-42/35L	708.1024.996.20	250	66.0	21.0	60	55	50	786

Baumaße sind Ungefähurmaße bei angezogener Überwurfmutter.

Sizes are approximate dimensions at tightened nut.

Las medidas son aproximadas con la tuerca de unión apretada.

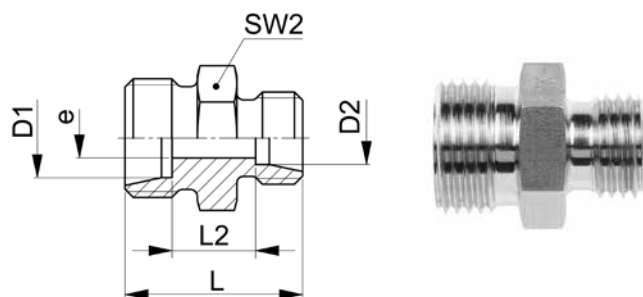
**Gerade Reduzierstutzen**
**Reducing connectors**
**Cuerpos de reducción rectos**

**XGR-..S**

Type-D1 / D2	Mat.-Nr.	PN	L	L2	SW2	e	g/Stk
XGR-08/06S	706.1024.140.30	800	32.0	18.0	17	4.0	39
XGR-10/06S	706.1024.175.30	800	32.0	17.5	19	4.0	46
XGR-10/08S	706.1024.190.30	800	32.0	17.5	19	5.0	48
XGR-12/06S	706.1024.215.30	630	34.0	19.5	22	4.0	62
XGR-12/08S	706.1024.225.30	630	34.0	19.5	22	5.0	64
XGR-12/10S	706.1024.240.30	630	34.0	19.0	22	7.0	64
XGR-14/06S	706.1024.296.30	630	36.0	20.5	24	4.0	77
XGR-14/08S	706.1024.300.30	630	36.0	20.5	24	5.0	79
XGR-14/10S	706.1024.320.30	630	36.0	20.0	24	7.0	79
XGR-14/12S	706.1024.340.30	630	36.0	20.0	24	8.0	80
XGR-16/06S	706.1024.466.30	630	36.0	20.0	27	4.0	92
XGR-16/08S	706.1024.468.30	630	36.0	20.0	27	5.0	94
XGR-16/10S	706.1024.470.30	630	36.0	19.5	27	7.0	93
XGR-16/12S	706.1024.480.30	630	36.0	19.5	27	8.0	95
XGR-16/14S	706.1024.500.30	630	38.0	21.0	27	10.0	98
XGR-20/06S	706.1024.650.30	420	40.0	22.0	32	4.0	149
XGR-20/08S	706.1024.655.30	420	40.0	22.0	32	5.0	150
XGR-20/10S	706.1024.660.30	420	40.0	21.5	32	7.0	148
XGR-20/12S	706.1024.665.30	420	40.0	21.5	32	8.0	149
XGR-20/14S	706.1024.675.30	420	42.0	23.0	32	10.0	154
XGR-20/16S	706.1024.685.30	420	42.0	22.5	32	12.0	152
XGR-25/06S	706.1024.788.30	420	44.0	24.5	41	5.0	248
XGR-25/08S	706.1024.787.30	420	44.0	24.5	41	4.0	249
XGR-25/10S	706.1024.789.30	420	44.0	24.0	41	7.0	259
XGR-25/12S	706.1024.791.30	420	46.0	25.5	41	10.0	263
XGR-25/14S	706.1024.790.30	420	44.0	24.0	41	8.0	260
XGR-25/16S	706.1024.800.30	420	46.0	25.0	41	12.0	260
XGR-25/20S	706.1024.820.30	420	48.0	25.0	41	16.0	265
XGR-30/10S	706.1024.939.30	420	46.0	24.5	46	7.0	344
XGR-30/12S	706.1024.940.30	420	46.0	24.5	46	8.0	345
XGR-30/14S	706.1024.941.30	420	46.0	24.0	46	10.0	343
XGR-30/16S	706.1024.942.30	420	48.0	25.5	46	12.0	345
XGR-30/20S	706.1024.943.30	420	50.0	25.5	46	16.0	349
XGR-30/25S	706.1024.945.30	420	52.0	26.0	46	20.0	358

Fortsetzung auf nächster linker Seite

To be continued on next left page

Continuación próxima página izquierda

**Gerade Reduzierschraubungen**  
**Straight reducing fittings**  
**Racores de reducción rectos**

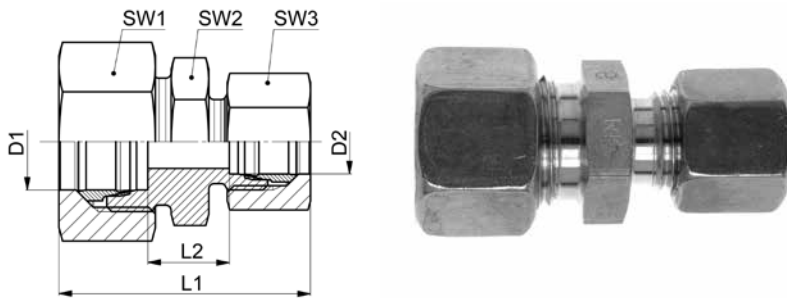

10

**GR..S**

Type-D1 / D2	Mat.-Nr.	PN	L1	L2	SW1	SW2	SW3	g/Stk
GR-08/06S	708.1024.140.30	800	48.0	18.0	19	17	17	85
GR-10/06S	708.1024.175.30	800	49.0	17.5	22	19	17	95
GR-10/08S	708.1024.190.30	800	49.0	17.5	22	19	19	100
GR-12/06S	708.1024.215.30	630	51.0	19.5	24	22	17	105
GR-12/08S	708.1024.225.30	630	51.0	19.5	24	22	19	115
GR-12/10S	708.1024.240.30	630	52.0	19.0	24	22	22	125
GR-14/06S	708.1024.296.30	630	54.0	21.0	27	24	17	125
GR-14/08S	708.1024.300.30	630	54.0	21.0	27	24	19	140
GR-14/10S	708.1024.320.30	630	55.0	20.5	27	24	22	125
GR-14/12S	708.1024.340.30	630	55.0	20.5	27	24	24	182
GR-16/06S	708.1024.466.30	630	54.0	20.5	30	27	17	170
GR-16/08S	708.1024.468.30	630	54.0	20.5	30	27	19	180
GR-16/10S	708.1024.470.30	630	55.0	20.0	30	27	22	185
GR-16/12S	708.1024.480.30	630	55.0	20.0	30	27	24	190
GR-16/14S	708.1024.500.30	630	58.0	21.5	30	27	27	215
GR-20/06S	708.1024.650.30	420	59.0	22.5	36	32	17	230
GR-20/08S	708.1024.655.30	420	59.0	22.5	36	32	19	250
GR-20/10S	708.1024.660.30	420	60.0	22.0	36	32	22	270
GR-20/12S	708.1024.665.30	420	60.0	22.0	36	32	24	312
GR-20/14S	708.1024.675.30	420	63.0	23.5	36	32	27	300
GR-20/16S	708.1024.685.30	420	63.0	23.0	36	32	30	315
GR-25/06S	708.1024.788.30	420	64.0	25.0	46	41	17	491
GR-25/08S	708.1024.787.30	420	64.0	25.0	46	41	19	495
GR-25/10S	708.1024.789.30	420	65.0	24.5	46	41	22	480
GR-25/12S	708.1024.791.30	420	65.0	26.0	46	41	24	500
GR-25/14S	708.1024.790.30	420	68.0	24.5	46	41	27	545
GR-25/16S	708.1024.800.30	420	68.0	25.5	46	41	30	552
GR-25/20S	708.1024.820.30	420	71.0	25.5	46	41	36	564
GR-30/10S	708.1024.939.30	420	68.0	25.0	50	46	22	548
GR-30/12S	708.1024.940.30	420	68.0	25.0	50	46	24	643
GR-30/14S	708.1024.941.30	420	69.0	24.5	50	46	27	580
GR-30/16S	708.1024.942.30	420	71.0	26.0	50	46	30	632
GR-30/20S	708.1024.943.30	420	74.0	26.0	50	46	36	778
GR-30/25S	708.1024.945.30	420	77.0	26.5	50	46	46	802

Fortsetzung auf nächster rechter Seite

To be continued on next right page

Continuación próxima página derecha

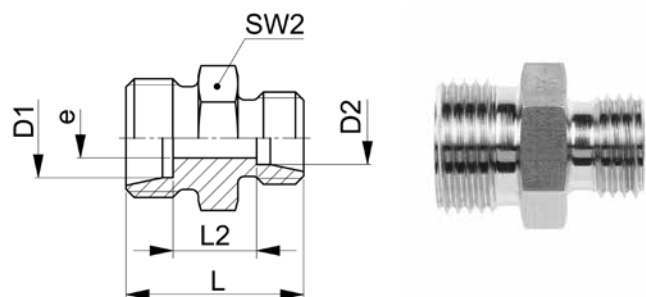
**Gerade Reduzierstutzen**
**Reducing connectors**
**Cuerpos de reducción rectos**

**XGR-..S**

Type -D1 /D2	Mat.-Nr.	PN	L	L2	SW2	e	g/Stk
XGR-38/10S	706.1024.967.30	420	51.0	27.0	55	7.0	571
XGR-38/12S	706.1024.968.30	420	51.0	27.0	55	8.0	571
XGR-38/14S	706.1024.969.30	420	53.0	28.5	55	10.0	573
XGR-38/16S	706.1024.970.30	420	53.0	28.0	55	12.0	570
XGR-38/20S	706.1024.971.30	420	55.0	28.0	55	16.0	573
XGR-38/25S	706.1024.972.30	420	57.0	28.5	55	20.0	579
XGR-38/30S	706.1024.975.30	420	59.0	29.0	55	25.0	580

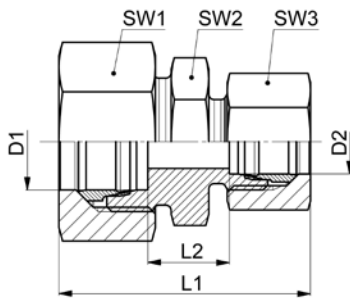
**Gerade Reduzierschraubungen**  
**Straight reducing fittings**  
**Racores de reducción rectos**



10

**GR..S**

Type -D1 /D2	Mat.-Nr.	PN	L1	L2	SW1	SW2	SW3	g/Stk
GR-38/10S	708.1024.967.30	420	75.0	27.5	60	55	22	870
GR-38/12S	708.1024.968.30	420	75.0	27.5	60	55	24	885
GR-38/14S	708.1024.969.30	420	78.0	29.0	60	55	27	910
GR-38/16S	708.1024.970.30	420	78.0	28.5	60	55	30	925
GR-38/20S	708.1024.971.30	420	81.0	28.5	60	55	36	975
GR-38/25S	708.1024.972.30	420	84.0	29.0	60	55	46	1090
GR-38/30S	708.1024.975.30	420	87.0	29.5	60	55	50	1216

Baumaße sind Ungefährmaße bei angezogener Überwurfmutter.

Sizes are approximate dimensions at tightened nut.

Las medidas son aproximadas con la tuerca de unión apretada.

**Konus-Reduzieranschlussstutzen mit Schaft**

schaftseitig vormontiert

**Reducing taper standpipe connectors**

pre-assembled on standpipe side

**Cuerpos de reducción cónicas con vástago**

premontado en lado de vástago

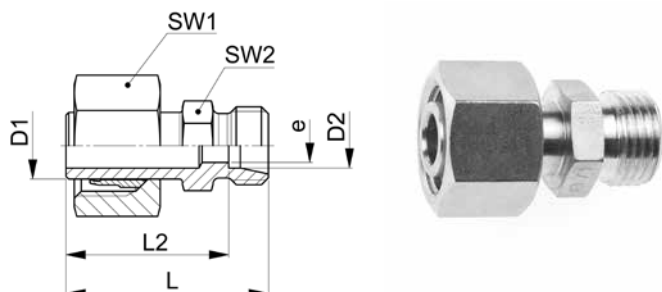

**XKR-..L M**

Type-D1 /D2	Mat.-Nr.	PN	L	L2	SW1	SW2	e	g/Stk
XKR-08/06L M	707.1821.140.20	500	35.0	28.0	17	12	4.0	30
XKR-10/06L M	707.1821.175.20	500	34.5	27.5	19	12	4.0	40
XKR-10/08L M	707.1821.190.20	500	35.5	28.5	19	14	6.5	38
XKR-12/06L M	707.1821.215.20	400	36.5	29.5	22	14	4.0	52
XKR-12/08L M	707.1821.225.20	400	36.5	29.5	22	14	6.0	52
XKR-12/10L M	707.1821.240.20	400	37.5	30.5	22	17	8.0	54
XKR-15/06L M	707.1821.391.20	400	37.0	30.0	27	17	4.0	70
XKR-15/08L M	707.1821.400.20	400	37.0	30.0	27	17	6.0	82
XKR-15/10L M	707.1821.410.20	400	38.0	31.0	27	17	8.0	80
XKR-15/12L M	707.1821.420.20	400	39.0	32.0	27	19	10.0	74
XKR-18/06L M	707.1821.563.20	400	38.5	31.5	32	19	4.0	96
XKR-18/08L M	707.1821.570.20	400	38.5	31.5	32	19	6.0	106
XKR-18/10L M	707.1821.575.20	400	38.5	31.5	32	19	8.0	122
XKR-18/12L M	707.1821.580.20	400	38.5	31.5	32	19	10.0	120
XKR-18/15L M	707.1821.610.20	400	39.5	32.5	32	24	12.0	128
XKR-22/06L M	707.1821.723.20	250	38.5	31.5	36	24	4.0	122
XKR-22/08L M	707.1821.724.20	250	38.5	31.5	36	24	6.0	129
XKR-22/10L M	707.1821.725.20	250	39.5	32.5	36	24	8.0	138
XKR-22/12L M	707.1821.730.20	250	39.5	32.5	36	24	10.0	150
XKR-22/15L M	707.1821.745.20	250	40.5	33.5	36	24	12.0	176
XKR-22/18L M	707.1821.755.20	250	41.5	34.0	36	27	15.0	178
XKR-28/06L M	707.1821.828.20	250	41.0	34.0	41	30	4.0	130
XKR-28/08L M	707.1821.829.20	250	41.0	34.0	41	30	6.0	140
XKR-28/10L M	707.1821.830.20	250	42.0	35.0	41	30	8.0	150
XKR-28/12L M	707.1821.835.20	250	42.0	35.0	41	30	10.0	170
XKR-28/15L M	707.1821.865.20	250	43.0	36.0	41	30	12.0	190
XKR-28/18L M	707.1821.870.20	250	43.0	35.5	41	30	15.0	210
XKR-28/22L M	707.1821.900.20	250	45.0	37.5	41	32	19.0	240

Fortsetzung auf nächster linker Seite

To be continued on next left page

Continuación próxima página izquierda

**Konus-Reduzieranschlüsse mit Schaft**

**Reducing taper standpipe fittings**

**Conexiones de reducción cónicas con vástago**

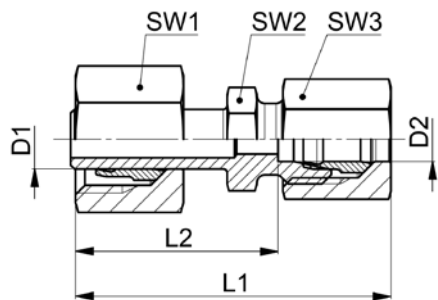

10

**KR-..L**

Type -D1 /D2	Mat.-Nr.	PN	L1	L2	SW1	SW2	SW3	g/Stk
KR-08/06L	708.1820.140.20	500	43.0	28.0	17	12	14	42
KR-10/06L	708.1820.175.20	500	42.5	27.5	19	12	14	55
KR-10/08L	708.1820.190.20	500	43.5	28.5	19	14	17	58
KR-12/06L	708.1820.215.20	400	44.5	29.5	22	14	14	63
KR-12/08L	708.1820.225.20	400	44.5	29.5	22	14	17	70
KR-12/10L	708.1820.240.20	400	45.5	30.5	22	17	19	72
KR-15/06L	708.1820.391.20	400	45.0	30.0	27	17	14	95
KR-15/08L	708.1820.400.20	400	45.0	30.0	27	17	17	98
KR-15/10L	708.1820.410.20	400	46.0	31.0	27	17	19	100
KR-15/12L	708.1820.420.20	400	47.0	32.0	27	19	22	104
KR-18/06L	708.1820.563.20	400	46.5	31.5	32	19	14	133
KR-18/08L	708.1820.570.20	400	46.5	31.5	32	19	17	135
KR-18/10L	708.1820.575.20	400	46.5	31.5	32	19	19	140
KR-18/12L	708.1820.580.20	400	46.5	31.5	32	19	22	145
KR-18/15L	708.1820.610.20	400	47.5	32.5	32	24	27	165
KR-22/06L	708.1820.723.20	250	46.5	31.5	36	24	14	152
KR-22/08L	708.1820.724.20	250	46.5	31.5	36	24	17	157
KR-22/10L	708.1820.725.20	250	47.5	32.5	36	24	19	170
KR-22/12L	708.1820.730.20	250	47.5	32.5	36	24	22	186
KR-22/15L	708.1820.745.20	250	48.5	33.5	36	24	27	214
KR-22/18L	708.1820.755.20	250	50.5	34.0	36	27	32	245
KR-28/06L	708.1820.828.20	250	49.0	34.0	41	30	14	185
KR-28/08L	708.1820.829.20	250	49.0	34.0	41	30	17	190
KR-28/10L	708.1820.830.20	250	50.0	35.0	41	30	19	215
KR-28/12L	708.1820.835.20	250	50.0	35.0	41	30	22	214
KR-28/15L	708.1820.865.20	250	51.0	36.0	41	30	27	245
KR-28/18L	708.1820.870.20	250	52.0	35.5	41	30	32	257
KR-28/22L	708.1820.900.20	250	54.5	37.5	41	32	36	310

Fortsetzung auf nächster rechter Seite

To be continued on next right page

Continuación próxima página derecha

**Konus-Reduzieranschlussstutzen mit Schaft**

schaftseitig vormontiert

**Reducing taper standpipe connectors**

pre-assembled on standpipe side

**Cuerpos de reducción cónicas con vástago**

premontado en lado de vástago

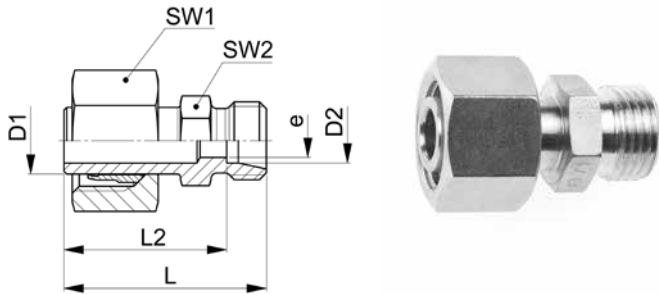

**XKR-..L M**

Type-D1 /D2	Mat.-Nr.	PN	L	L2	SW1	SW2	e	g/Stk
XKR-35/06L M	707.1821.951.20	250	50.5	43.5	50	36	12.0	318
XKR-35/08L M	707.1821.952.20	250	50.5	43.0	50	36	15.0	324
XKR-35/10L M	707.1821.953.20	250	52.5	45.0	50	36	19.0	328
XKR-35/12L M	707.1821.954.20	250	52.5	45.0	50	41	24.0	404
XKR-35/15L M	707.1821.946.20	250	48.5	41.5	50	36	4.0	272
XKR-35/18L M	707.1821.947.20	250	48.5	41.5	50	36	6.0	282
XKR-35/22L M	707.1821.948.20	250	49.5	42.5	50	36	8.0	292
XKR-35/28L M	707.1821.949.20	250	49.5	42.5	50	36	10.0	312
XKR-42/10L M	707.1821.988.20	250	52.5	45.5	60	46	8.0	482
XKR-42/12L M	707.1821.989.20	250	52.5	45.5	60	46	10.0	488
XKR-42/15L M	707.1821.991.20	250	53.5	46.5	60	46	12.0	490
XKR-42/18L M	707.1821.992.20	250	53.5	46.0	60	46	15.0	500
XKR-42/22L M	707.1821.993.20	250	55.5	48.0	60	46	19.0	512
XKR-42/28L M	707.1821.994.20	250	55.5	48.0	60	46	24.0	518
XKR-42/35L M	707.1821.996.20	250	57.5	47.0	60	46	30.0	588

Achtung: Endmontage des vormontierten Schaftes wird erst nach 1/4 Umdrehung der Überwurfmutter über den Punkt des deutlich fühlbaren Kraftanstiegs erreicht.

Attention: Final standpipe assembly, the nut will be tightened at least by 1/4 of a turn beyond the point of a noticeable increase in force.

Atención: El montaje del vástago premontado se completa girando 1/4 vuelta la tuerca de unión a partir del punto en que aumenta claramente la resistencia.

**Konus-Reduzieranschlüsse mit Schaft**  
**Reducing taper standpipe fittings**  
**Conexiones de reducción cónicas con vástago**

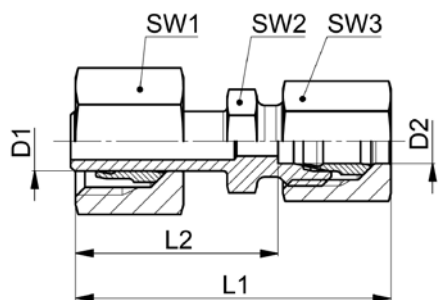

10

**KR-..L**

Type -D1 /D2	Mat.-Nr.	PN	L1	L2	SW1	SW2	SW3	g/Stk
KR-35/06L	708.1820.951.20	250	56.5	41.5	50	36	14	314
KR-35/08L	708.1820.952.20	250	56.5	41.5	50	36	17	318
KR-35/10L	708.1820.953.20	250	57.5	42.5	50	36	19	325
KR-35/12L	708.1820.954.20	250	57.5	45.0	50	36	22	345
KR-35/15L	708.1820.946.20	250	58.5	43.5	50	36	27	368
KR-35/18L	708.1820.947.20	250	59.5	43.0	50	36	32	392
KR-35/22L	708.1820.948.20	250	61.5	45.0	50	36	36	480
KR-35/28L	708.1820.949.20	250	61.5	45.0	50	41	41	426
KR-42/10L	708.1820.988.20	250	60.5	45.5	60	46	19	515
KR-42/12L	708.1820.989.20	250	60.5	45.5	60	46	22	524
KR-42/15L	708.1820.991.20	250	61.5	46.5	60	46	27	530
KR-42/18L	708.1820.992.20	250	62.5	46.0	60	46	32	530
KR-42/22L	708.1820.993.20	250	64.5	48.0	60	46	36	540
KR-42/28L	708.1820.994.20	250	64.5	48.0	60	46	41	576
KR-42/35L	708.1820.996.20	250	68.5	47.0	60	46	50	640

Baumaße sind Ungefährmaße bei angezogener Überwurfmutter.

Sizes are approximate dimensions at tightened nut.

Las medidas son aproximadas con la tuerca de unión apretada.

Achtung: Endmontage des vormontierten Schaftes wird erst nach 1/4 Umdrehung der Überwurfmutter über den Punkt des deutlich fühlbaren Kraftanstiegs erreicht.

Attention: Final standpipe assembly, the nut will be tightened at least by 1/4 of a turn beyond the point of a noticeable increase in force.

Atención: El montaje del vástago premontado se completa girando 1/4 vuelta la tuerca de unión a partir del punto en que aumenta claramente la resistencia.

**Konus-Reduzieranschlussstutzen mit Schaft**

schaftseitig vormontiert

**Reducing taper standpipe connectors**

pre-assembled on standpipe side

**Cuerpos de reducción cónicas con vástago**

premontado en lado de vástago

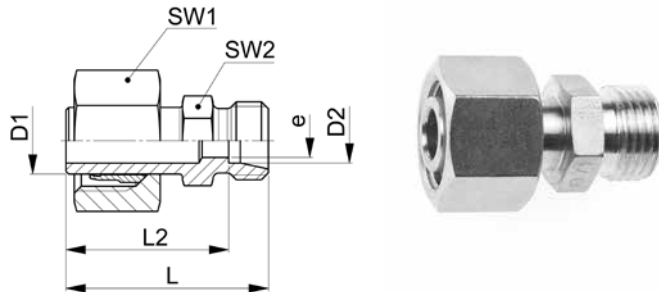

**XKR-..S M**

Type-D1 /D2	Mat.-Nr.	PN	L	L2	SW1	SW2	e	g/Stk
XKR-08/06S M	707.1821.140.30	800	38.5	31.5	19	14	4.3	48
XKR-10/06S M	707.1821.175.30	800	40.5	33.5	22	14	4.0	60
XKR-10/08S M	707.1821.190.30	800	41.0	34.0	22	17	6.0	68
XKR-12/06S M	707.1821.215.30	630	40.0	33.0	24	14	4.0	68
XKR-12/08S M	707.1821.225.30	630	40.5	33.0	24	17	5.0	74
XKR-12/10S M	707.1821.240.30	630	40.5	33.0	24	19	7.0	76
XKR-14/06S M	707.1821.296.30	630	42.0	35.0	27	17	4.0	102
XKR-14/08S M	707.1821.300.30	630	42.0	35.0	27	17	5.0	108
XKR-14/10S M	707.1821.320.30	630	42.0	34.5	27	19	7.0	112
XKR-14/12S M	707.1821.340.30	630	43.0	35.5	27	22	9.0	118
XKR-16/06S M	707.1821.466.30	630	43.0	36.0	30	17	4.0	110
XKR-16/08S M	707.1821.468.30	630	43.0	36.0	30	17	5.0	116
XKR-16/10S M	707.1821.470.30	630	43.0	35.5	30	19	7.0	130
XKR-16/12S M	707.1821.480.30	630	44.0	36.5	30	22	8.0	142
XKR-16/14S M	707.1821.500.30	630	47.0	39.0	30	24	10.5	152
XKR-20/06S M	707.1821.650.30	420	49.0	42.0	36	22	4.0	176
XKR-20/08S M	707.1821.655.30	420	49.0	42.0	36	22	5.0	182
XKR-20/10S M	707.1821.660.30	420	49.0	41.5	36	22	7.0	186
XKR-20/12S M	707.1821.665.30	420	49.0	41.5	36	22	8.0	192
XKR-20/14S M	707.1821.675.30	420	52.0	44.0	36	24	10.0	220
XKR-20/16S M	707.1821.685.30	420	52.0	43.5	36	27	12.0	224
XKR-25/06S M	707.1821.788.30	420	53.0	46.0	46	27	5.0	332
XKR-25/08S M	707.1821.787.30	420	53.0	46.0	46	27	4.0	330
XKR-25/10S M	707.1821.789.30	420	53.0	45.5	46	27	7.0	334
XKR-25/12S M	707.1821.791.30	420	55.0	47.0	46	27	10.0	365
XKR-25/14S M	707.1821.790.30	420	53.0	45.5	46	27	8.0	344
XKR-25/16S M	707.1821.795.30	420	55.0	46.5	46	27	12.0	380
XKR-25/20S M	707.1821.820.30	420	58.0	47.5	46	32	17.0	400

Fortsetzung auf nächster linker Seite

To be continued on next left page

Continuación próxima página izquierda

**Konus-Reduzieranschlüsse mit Schaft**

**Reducing taper standpipe fittings**

**Conexiones de reducción cónicas con vástago**

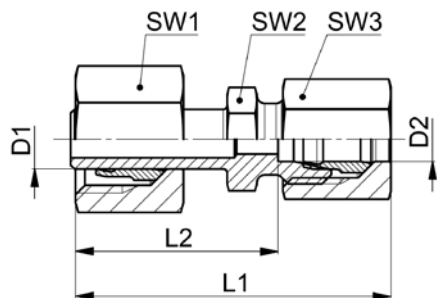

10

**KR-..S**

Type -D1 /D2	Mat.-Nr.	PN	L1	L2	SW1	SW2	SW3	g/Stk
KR-08/06S	708.1820.140.30	800	46.5	31.5	19	14	17	68
KR-10/06S	708.1820.175.30	800	48.5	33.5	22	14	17	80
KR-10/08S	708.1820.190.30	800	49.0	34.0	22	17	19	85
KR-12/06S	708.1820.215.30	630	48.0	33.0	24	14	17	90
KR-12/08S	708.1820.225.30	630	48.5	33.5	24	17	19	98
KR-12/10S	708.1820.240.30	630	49.5	33.0	24	19	22	100
KR-14/06S	708.1820.296.30	630	50.0	35.0	27	17	17	105
KR-14/08S	708.1820.300.30	630	50.0	35.0	27	17	19	110
KR-14/10S	708.1820.320.30	630	51.0	34.5	27	19	22	125
KR-14/12S	708.1820.340.30	630	52.0	35.5	27	22	24	130
KR-16/06S	708.1820.466.30	630	51.0	36.0	30	17	17	135
KR-16/08S	708.1820.468.30	630	51.0	36.0	30	17	19	140
KR-16/10S	708.1820.470.30	630	52.0	35.5	30	19	22	145
KR-16/12S	708.1820.480.30	630	53.0	36.5	30	22	24	150
KR-16/14S	708.1820.500.30	630	57.0	39.0	30	24	27	169
KR-20/06S	708.1820.650.30	420	57.0	42.0	36	22	17	195
KR-20/08S	708.1820.655.30	420	57.0	42.0	36	22	19	203
KR-20/10S	708.1820.660.30	420	58.0	41.5	36	22	22	220
KR-20/12S	708.1820.665.30	420	58.0	41.5	36	22	24	240
KR-20/14S	708.1820.675.30	420	62.0	44.0	36	24	27	250
KR-20/16S	708.1820.685.30	420	62.0	43.5	36	27	30	265
KR-25/06S	708.1820.788.30	420	61.0	46.0	46	27	17	350
KR-25/08S	708.1820.787.30	420	61.0	46.0	46	27	19	360
KR-25/10S	708.1820.789.30	420	62.0	45.5	46	27	22	430
KR-25/12S	708.1820.791.30	420	62.0	45.5	46	27	24	384
KR-25/14S	708.1820.790.30	420	65.0	47.0	46	27	27	381
KR-25/16S	708.1820.795.30	420	65.0	46.5	46	27	30	405
KR-25/20S	708.1820.820.30	420	69.0	47.5	46	32	36	415

Fortsetzung auf nächster rechter Seite

To be continued on next right page

Continuación próxima página derecha

**Konus-Reduzieranschlussstutzen mit Schaft**

schaftseitig vormontiert

**Reducing taper standpipe connectors**

pre-assembled on standpipe side

**Cuerpos de reducción cónicas con vástago**

premontado en lado de vástago

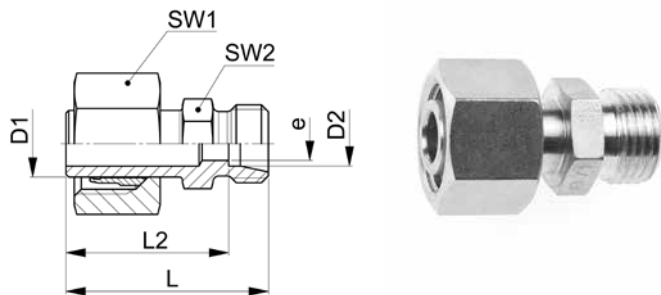

**XKR-..S M**

Type-D1 /D2	Mat.-Nr.	PN	L	L2	SW1	SW2	e	g/Stk
XKR-30/06S M	707.1821.937.30	420	56.5	49.5	50	32	5.0	418
XKR-30/08S M	707.1821.936.30	420	56.5	49.5	50	32	4.0	408
XKR-30/10S M	707.1821.939.30	420	56.5	49.0	50	32	7.0	428
XKR-30/12S M	707.1821.940.30	420	56.5	49.0	50	32	8.0	430
XKR-30/14S M	707.1821.941.30	420	58.5	50.5	50	32	10.0	502
XKR-30/16S M	707.1821.942.30	420	58.5	50.0	50	32	12.0	518
XKR-30/20S M	707.1821.943.30	420	60.5	50.0	50	32	16.0	532
XKR-30/25S M	707.1821.945.30	420	63.5	51.5	50	41	20.0	582
XKR-38/06S M	707.1821.965.30	420	62.0	55.0	60	41	4.0	605
XKR-38/08S M	707.1821.966.30	420	62.0	55.0	60	41	5.0	612
XKR-38/10S M	707.1821.967.30	420	62.0	54.5	60	41	7.0	622
XKR-38/12S M	707.1821.968.30	420	62.0	54.5	60	41	8.0	634
XKR-38/14S M	707.1821.969.30	420	64.0	56.0	60	41	10.0	645
XKR-38/16S M	707.1821.970.30	420	64.0	55.5	60	41	12.0	656
XKR-38/20S M	707.1821.971.30	420	66.0	55.5	60	41	16.0	674
XKR-38/25S M	707.1821.972.30	420	68.0	56.0	60	41	20.0	708
XKR-38/30S M	707.1821.975.30	420	72.0	58.5	60	46	25.0	818

Achtung: Endmontage des vormontierten Schaftes wird erst nach 1/4 Umdrehung der Überwurfmutter über den Punkt des deutlich fühlbaren Kraftanstiegs erreicht.

Attention: Final standpipe assembly, the nut will be tightened at least by 1/4 of a turn beyond the point of a noticeable increase in force.

Atención: El montaje del vástago premontado se completa girando 1/4 vuelta la tuerca de unión a partir del punto en que aumenta claramente la resistencia.

**Konus-Reduzieranschlüsse mit Schaft**

**Reducing taper standpipe fittings**

**Conexiones de reducción cónicas con vástago**

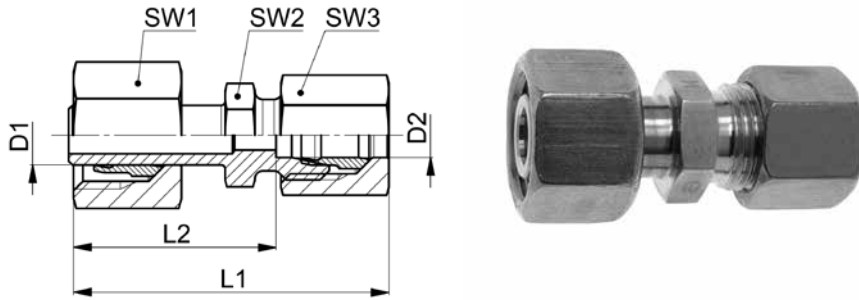

**KR-..S**

Type -D1 /D2	Mat.-Nr.	PN	L1	L2	SW1	SW2	SW3	g/Stk
KR-30/06S	708.1820.937.30	420	64.5	49.5	50	32	17	390
KR-30/08S	708.1820.936.30	420	64.5	49.5	50	32	19	405
KR-30/10S	708.1820.939.30	420	65.5	49.0	50	32	22	410
KR-30/12S	708.1820.940.30	420	65.5	49.0	50	32	24	414
KR-30/14S	708.1820.941.30	420	68.5	50.5	50	32	27	465
KR-30/16S	708.1820.942.30	420	68.5	50.0	50	32	30	467
KR-30/20S	708.1820.943.30	420	71.5	50.0	50	32	36	510
KR-30/25S	708.1820.945.30	420	75.5	51.5	50	41	46	632
KR-38/06S	708.1820.965.30	420	70.0	55.0	60	41	17	545
KR-38/08S	708.1820.966.30	420	70.0	55.0	60	41	19	555
KR-38/10S	708.1820.967.30	420	71.0	54.5	60	41	22	575
KR-38/12S	708.1820.968.30	420	71.0	54.5	60	41	24	580
KR-38/14S	708.1820.969.30	420	74.0	56.0	60	41	27	617
KR-38/16S	708.1820.970.30	420	74.0	55.5	60	41	30	620
KR-38/20S	708.1820.971.30	420	77.0	55.5	60	41	36	820
KR-38/25S	708.1820.972.30	420	80.0	56.0	60	41	46	880
KR-38/30S	708.1820.975.30	420	85.0	58.5	60	46	50	910

Baumaße sind Ungefährmaße bei angezogener Überwurfmutter.

Achtung: Endmontage des vormontierten Schaftes wird erst nach 1/4 Umdrehung der Überwurfmutter über den Punkt des deutlich fühlbaren Kraftanstiegs erreicht.

Sizes are approximate dimensions at tightened nut.

Attention: Final standpipe assembly, the nut will be tightened at least by 1/4 of a turn beyond the point of a noticeable increase in force.

Las medidas son aproximadas con la tuerca de unión apretada.

Atención: El montaje del vástago premontado se completa girando 1/4 vuelta la tuerca de unión a partir del punto en que aumenta claramente la resistencia.

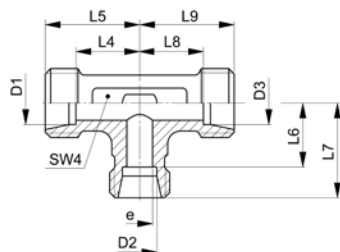
**T-Reduzierstutzen**
**Reducing T connectors**
**Cuerpos de reducción T**

**XTR-..L/S**

Type-D1 /D2 /D3	Mat.-Nr.	PN	L4	L5	L6	L7	L8	L9	SW4	e	g/Stk
XTR-06/08/06L	706.3004.058.20	500	14.0	21.0	14.0	21.0	14.0	21.0	12	4.0	37
XTR-06/10/06L	706.3004.061.20	500	15.0	22.0	15.0	22.0	15.0	22.0	14	4.0	48
XTR-08/06/08L	706.3004.093.20	500	14.0	21.0	14.0	21.0	14.0	21.0	12	4.0	30
XTR-08/10/08L	706.3004.104.20	500	15.0	22.0	15.0	22.0	15.0	22.0	14	6.0	48
XTR-10/06/10L	706.3004.147.20	500	15.0	22.0	15.0	22.0	15.0	22.0	14	4.0	40
XTR-10/08/10L	706.3004.153.20	500	15.0	22.0	15.0	22.0	15.0	22.0	14	6.0	47
XTR-10/10/08L	706.3004.160.20	500	15.0	22.0	15.0	22.0	15.0	22.0	14	6.0	47
XTR-10/15/10L	706.3004.175.20	500	21.0	28.0	21.0	28.0	21.0	28.0	19	8.0	111
XTR-12/08/12L	706.3004.210.20	400	17.0	24.0	17.0	24.0	17.0	24.0	17	6.0	64
XTR-12/10/12L	706.3004.222.20	400	17.0	24.0	17.0	24.0	17.0	24.0	17	8.0	63
XTR-12/12/10L	706.3004.232.20	400	17.0	24.0	17.0	24.0	17.0	24.0	17	8.0	64
XTR-12/18/12L	706.3004.258.20	400	24.0	31.0	23.5	31.0	24.0	31.0	24	10.0	140
XTR-15/12/15L	706.3004.422.20	400	21.0	28.0	21.0	28.0	21.0	28.0	19	10.0	109
XTR-18/10/10L	706.3004.575.20	400	23.5	31.0	24.0	31.0	24.0	31.0	24	8.0	190
XTR-18/10/18L	706.3004.584.20	400	23.5	31.0	24.0	31.0	23.5	31.0	24	8.0	180
XTR-18/12/18L	706.3004.599.20	400	23.5	31.0	23.5	31.0	23.5	31.0	24	10.0	150
XTR-18/18/10L	706.3004.637.20	400	23.5	31.0	23.5	31.0	23.5	31.0	24	9.0	162
XTR-22/10/22L	706.3004.738.20	250	27.5	35.0	28.0	35.0	27.5	35.0	27	8.0	270
XTR-22/12/22L	706.3004.740.20	250	27.5	35.0	28.0	35.0	27.5	35.0	27	10.0	270
XTR-22/15/22L	706.3004.800.20	250	27.5	35.0	28.0	35.0	27.5	35.0	27	12.0	270
XTR-22/18/18L	706.3004.854.20	250	27.5	35.0	27.5	35.0	27.5	35.0	27	15.0	257
XTR-22/18/22L	706.3004.862.20	250	27.5	35.0	28.0	35.0	27.5	35.0	27	15.0	239
XTR-28/10/28L	706.3004.906.20	250	30.5	38.0	31.0	38.0	30.5	38.0	36	8.0	370
XTR-28/12/28L	706.3004.916.20	250	30.5	38.0	31.0	38.0	30.5	38.0	36	10.0	380
XTR-28/18/28L	706.3004.928.20	250	30.5	38.0	30.5	38.0	30.5	38.0	36	15.0	382
XTR-28/22/28L	706.3004.948.20	250	30.5	38.0	30.5	38.0	30.5	38.0	36	19.0	361
XTR-12/16/12S	706.3004.256.30	630	25.5	33.0	24.5	33.0	25.5	33.0	24	8.0	170
XTR-16/10/16S	706.3004.454.30	630	24.5	33.0	25.5	33.0	24.5	33.0	24	8.0	198
XTR-16/12/16S	706.3004.455.30	630	24.5	33.0	25.5	33.0	24.5	33.0	24	9.0	198
XTR-20/12/20S	706.3004.680.30	420	26.5	37.0	25.5	33.0	26.5	37.0	27	9.0	278
XTR-25/16/25S	706.3004.900.30	420	30.0	42.0	33.5	42.0	30.0	42.0	36	12.0	489
XTR-30/16/30S	706.3004.970.30	420	35.5	49.0	40.5	49.0	35.5	49.0	41	14.0	750

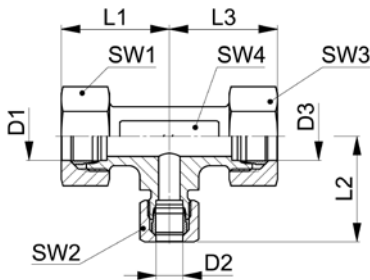
**T-Reduzierschraubungen**  
**Reducing T fittings**  
**Racores de reducción T**



10

**TR-..L/S**

Type -D1 /D2 /D3	Mat.-Nr.	PN	L1	L2	L3	SW1	SW2	SW3	SW4	g/Stk
TR-06/08/06L	708.3004.058.20	500	29.0	29.0	29.0	14	17	14	12	82
TR-06/10/06L	708.3004.061.20	500	30.0	30.5	30.0	14	19	14	14	97
TR-08/06/08L	708.3004.093.20	500	29.0	29.0	29.0	17	14	17	12	80
TR-08/10/08L	708.3004.104.20	500	30.0	30.5	30.0	17	19	17	14	109
TR-10/06/10L	708.3004.147.20	500	30.5	30.0	30.5	19	14	19	14	100
TR-10/08/10L	708.3004.153.20	500	30.5	30.0	30.5	19	17	19	14	113
TR-10/10/08L	708.3004.160.20	500	30.5	30.0	30.5	19	19	17	14	113
TR-10/15/10L	708.3004.175.20	400	36.5	37.0	36.5	19	27	19	19	208
TR-12/08/12L	708.3004.210.20	400	32.5	32.0	32.5	22	17	22	17	145
TR-12/10/12L	708.3004.222.20	400	32.5	32.5	32.5	22	19	22	17	150
TR-12/12/10L	708.3004.232.20	400	32.5	32.5	32.5	22	22	19	17	150
TR-12/18/12L	708.3004.258.20	400	39.5	40.5	39.5	22	32	22	24	276
TR-15/12/15L	708.3004.422.20	400	37.0	36.5	37.0	27	22	27	19	240
TR-18/10/10L	708.3004.575.20	400	40.5	39.0	39.5	32	19	19	24	310
TR-18/10/18L	708.3004.584.20	400	40.5	39.5	40.5	32	19	32	24	370
TR-18/12/18L	708.3004.599.20	400	40.5	39.5	40.5	32	22	32	24	341
TR-18/18/10L	708.3004.637.20	400	40.5	40.5	39.5	32	32	19	24	351
TR-22/10/22L	708.3004.738.20	250	44.5	43.5	44.5	36	19	36	27	486
TR-22/12/22L	708.3004.740.20	250	44.5	43.5	44.5	36	22	36	27	494
TR-22/15/22L	708.3004.800.20	250	44.5	44.0	44.5	36	27	36	27	513
TR-22/18/18L	708.3004.854.20	250	44.0	43.0	43.5	36	32	32	27	480
TR-22/18/22L	708.3004.862.20	250	44.5	44.5	44.5	36	32	36	27	506
TR-28/10/28L	708.3004.906.20	250	47.5	46.5	47.5	41	19	41	36	624
TR-28/12/28L	708.3004.916.20	250	47.5	46.5	47.5	41	22	41	36	643
TR-28/18/28L	708.3004.928.20	250	47.5	47.5	47.5	41	32	41	36	685
TR-28/22/28L	708.3004.948.20	250	47.5	47.5	47.5	41	36	41	36	688
TR-12/16/12S	708.3004.256.30	630	42.5	44.0	42.5	24	30	24	24	313
TR-16/10/16S	708.3004.454.30	630	44.0	42.5	44.0	30	22	30	24	419
TR-16/12/16S	708.3004.455.30	630	44.0	42.5	44.0	30	24	30	24	376
TR-20/12/20S	708.3004.680.30	420	49.5	49.5	42.5	36	24	36	27	580
TR-25/16/25S	708.3004.900.30	420	55.5	53.0	55.5	46	30	46	36	1050
TR-30/16/30S	708.3004.970.30	420	63.5	60.0	63.5	50	30	50	41	1320

Baumäße sind Ungefährmaße bei angezogener Überwurfmutter.

Sizes are approximate dimensions at tightened nut.

Las medidas son aproximadas con la tuerca de unión apretada.

**Gerade Anschweißstutzen**  
**Straight weld-on connectors**  
**Cuerpos para soldar rectos**

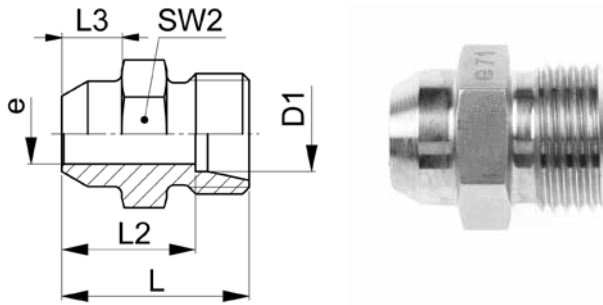

**XGAS-..L/S**

Type -D1	Mat.-Nr.	PN	L	L2	L3	SW2	e	g/Stk
XGAS-06L	706.1400.060.20	500	21.0	14.0	7.0	12	4.0	10
XGAS-08L	706.1400.080.20	500	23.0	16.0	8.0	14	6.0	14
XGAS-10L	706.1400.100.20	500	25.0	18.0	8.0	17	8.0	22
XGAS-12L	706.1400.120.20	400	25.0	18.0	8.0	19	10.0	26
XGAS-15L	706.1400.150.20	400	29.0	22.0	10.0	22	12.0	48
XGAS-18L	706.1400.180.20	400	31.0	23.5	10.0	27	15.0	68
XGAS-22L	706.1400.220.20	250	36.0	28.5	12.0	32	19.0	98
XGAS-28L	706.1400.280.20	250	38.0	30.5	12.0	41	24.0	162
XGAS-35L	706.1400.350.20	250	43.0	32.5	14.0	46	30.0	238
XGAS-42L	706.1400.420.20	250	46.0	35.0	16.0	55	36.0	336
XGAS-06S	706.1400.060.30	800	26.0	19.0	7.0	14	4.0	18
XGAS-08S	706.1400.080.30	800	28.0	21.0	8.0	17	5.0	30
XGAS-10S	706.1400.100.30	800	30.0	22.5	8.0	19	7.0	40
XGAS-12S	706.1400.120.30	630	32.0	24.5	10.0	22	8.0	56
XGAS-14S	706.1400.140.30	630	35.0	27.0	10.0	24	10.0	70
XGAS-16S	706.1400.160.30	630	35.0	26.5	10.0	27	12.0	84
XGAS-20S	706.1400.200.30	420	40.0	29.5	12.0	32	16.0	130
XGAS-25S	706.1400.250.30	420	44.0	32.0	12.0	41	20.0	224
XGAS-30S	706.1400.300.30	420	49.0	35.5	14.0	46	25.0	302
XGAS-38S	706.1400.380.30	420	54.0	38.0	16.0	55	32.0	462

ISO 8434-1-WDS

**Gerade Anschweißverschraubungen**  
**Straight weld-on fittings**  
**Racores para soldar rectos**

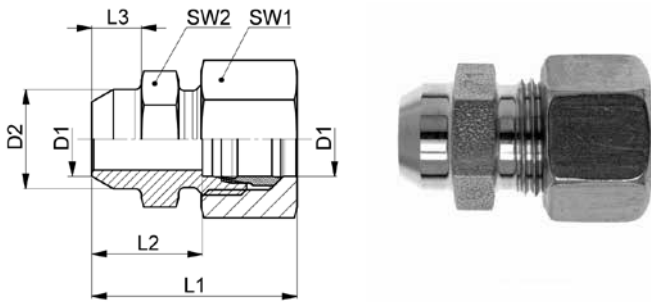

10

**GAS-..L/S**

Type -D1	Mat.-Nr.	PN	D2	L1	L2	L3	SW1	SW2	g/Stk
GAS-06L	708.1400.060.20	500	10.0	29.0	14.0	7.0	14	12	25
GAS-08L	708.1400.080.20	500	12.0	31.0	16.0	8.0	17	14	36
GAS-10L	708.1400.100.20	500	14.0	33.0	18.0	8.0	19	17	47
GAS-12L	708.1400.120.20	400	16.0	33.0	18.0	8.0	22	19	55
GAS-15L	708.1400.150.20	400	19.0	37.0	22.0	10.0	27	22	90
GAS-18L	708.1400.180.20	400	22.0	40.0	23.5	10.0	32	27	130
GAS-22L	708.1400.220.20	250	27.0	45.0	28.5	12.0	36	32	190
GAS-28L	708.1400.280.20	250	32.0	47.0	30.5	12.0	41	41	270
GAS-35L	708.1400.350.20	250	40.0	54.0	32.5	14.0	50	46	395
GAS-42L	708.1400.420.20	250	46.0	58.0	35.0	16.0	60	55	585
GAS-06S	708.1400.060.30	800	11.0	34.0	19.0	7.0	17	14	38
GAS-08S	708.1400.080.30	800	13.0	36.0	21.0	8.0	19	17	54
GAS-10S	708.1400.100.30	800	15.0	39.0	22.5	8.0	22	19	70
GAS-12S	708.1400.120.30	630	17.0	41.0	24.5	10.0	24	22	125
GAS-14S	708.1400.140.30	630	19.0	45.0	27.0	10.0	27	24	140
GAS-16S	708.1400.160.30	630	21.0	45.0	26.5	10.0	30	27	156
GAS-20S	708.1400.200.30	420	26.0	51.0	29.5	12.0	36	32	240
GAS-25S	708.1400.250.30	420	31.0	56.0	32.0	12.0	46	41	460
GAS-30S	708.1400.300.30	420	36.0	62.0	35.5	14.0	50	46	555
GAS-38S	708.1400.380.30	420	44.0	69.0	38.0	16.0	60	55	786

Baumaße sind Ungefährmaße bei angezogener Überwurfmutter.

Sizes are approximate dimensions at tightened nut.

Las medidas son aproximadas con la tuerca de unión apretada.

Nach dem Anschweißen die in der Montageanleitung angegebenen Stellen nochmals mit der ASW Fettpaste schmieren (Schneidring, Gewinde der Mutter).

After welding, coat the parts indicated in the assembly instructions with ASW grease (cutting ring, thread of nut).

Luego de soldar, aplique nuevamente la grasa ASW en las partes indicadas en las instrucciones de montaje (anillo cortante, roscas de tuercas).

**ISO 8434-1-WDSC**

**Gerade Anschweißstutzen**  
**Straight weld-on connectors**  
**Cuerpos para soldar rectos**

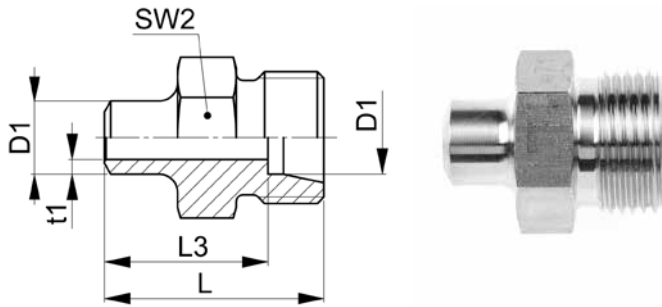

**XGASK-..**

Type-D1 x t1	Mat.-Nr.	PN	L	L3	SW2	g/Stk
XGASK-10x2,0	706.1451.108.30	800	30.0	22.4	19	34
XGASK-12x2,5	706.1451.123.30	630	30.0	22.4	22	52
XGASK-16x3,0	706.1451.163.30	630	41.0	32.4	27	88
XGASK-20x4,0	706.1451.203.30	420	47.0	36.4	32	144
XGASK-25x5,0	706.1451.256.30	420	52.0	39.9	41	260
XGASK-30x6,0	706.1451.306.30	420	60.0	46.4	46	382
XGASK-38x7,0	706.1451.383.30	420	60.0	43.9	55	562

**Gerade Anschweißverschraubungen**

mit Schweißkegel und O-Ring

**Straight weld-on fittings**

with weldable cone and O-ring

**Racores para soldar rectos**

con cono para soldar y junta tórica

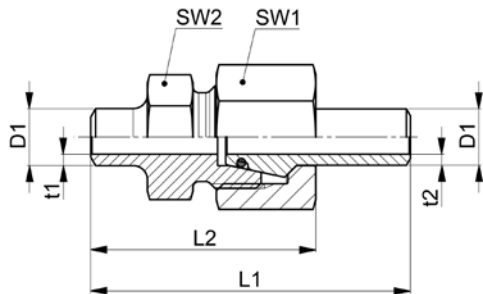

10

**GASK..**

Type-D1 x t1	Mat.-Nr.	PN	L1	L2	t2	SW1	SW2	g/Stk
GASK-10x2,0	708.1451.108.30	800	56.0	39.5	2.0	22	19	77
GASK-12x2,5	708.1451.123.30	630	56.0	39.5	2.5	24	22	108
GASK-16x3,0	708.1451.163.30	630	74.0	52.0	3.0	30	27	193
GASK-20x4,0	708.1451.203.30	420	84.0	60.0	4.0	36	32	322
GASK-25x5,0	708.1451.256.30	420	94.0	66.0	5.0	46	41	600
GASK-30x6,0	708.1451.306.30	420	104.0	75.5	6.0	50	46	802
GASK-38x7,0	708.1451.383.30	420	108.5	77.0	7.0	60	55	1214

Baumaße sind Ungefährmaße bei angezogener Überwurfmutter.

Nach dem Anschweißen die in der Montageanleitung angegebenen Stellen nochmals mit der ASW Fettpaste schmieren (Schneidring, Gewinde der Mutter).

Dichtungsmaterial: FKM

Sizes are approximate dimensions at tightened nut.

After welding, coat the parts indicated in the assembly instructions with ASW grease (cutting ring, thread of nut).

Sealing material: FKM

Las medidas son aproximadas con la tuerca de unión apretada.

Material de junta tórica: FKM

Luego de soldar, aplique nuevamente la grasa ASW en las partes indicadas en las instrucciones de montaje (anillo cortante, roscas de tuercas).

**Winkelanschweißstutzen**  
**Elbow weld-on connectors**  
**Cuerpos para soldar angulares**

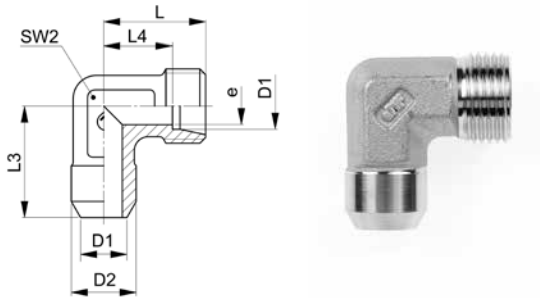

**XWAS-..L/S**

Type -D1	Mat.-Nr.	PN	D2	L	L3	L4	SW2	e	g/Stk
XWAS-06L	706.2400.060.20	500	10.0	19.0	19.0	12.0	12	4.0	22
XWAS-08L	706.2400.080.20	500	12.0	21.0	23.0	14.0	12	6.0	27
XWAS-10L	706.2400.100.20	500	14.0	22.0	24.0	15.0	14	8.0	36
XWAS-12L	706.2400.120.20	400	16.0	24.0	25.0	17.0	17	10.0	48
XWAS-15L	706.2400.150.20	400	19.0	28.0	30.0	21.0	19	12.0	83
XWAS-18L	706.2400.180.20	400	22.0	31.0	33.0	23.5	24	15.0	121
XWAS-22L	706.2400.220.20	250	27.0	35.0	37.0	27.5	27	19.0	164
XWAS-28L	706.2400.280.20	250	32.0	38.0	42.0	30.5	36	24.0	274
XWAS-06S	706.2400.060.30	800	11.0	23.0	23.0	16.0	12	6.0	37
XWAS-08S	706.2400.080.30	800	13.0	24.0	24.0	17.0	14	5.0	51
XWAS-10S	706.2400.100.30	800	15.0	25.0	25.0	17.5	17	7.0	62
XWAS-12S	706.2400.120.30	630	17.0	29.0	29.0	21.5	17	8.0	86
XWAS-14S	706.2400.140.30	630	19.0	30.0	30.0	22.0	19	10.0	103
XWAS-16S	706.2400.160.30	630	21.0	33.0	33.0	24.5	24	12.0	146
XWAS-20S	706.2400.200.30	420	26.0	37.0	37.0	26.5	27	16.0	206
XWAS-25S	706.2400.250.30	420	31.0	42.0	42.0	30.0	36	20.0	369

**Winkelanschweißverschraubungen**  
**Elbow weld-on fittings**  
**Racores para soldar angulares**

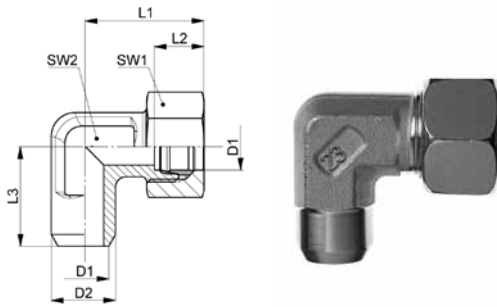

**WAS-..L/S**

Type -D1	Mat.-Nr.	PN	D2	L1	L2	L3	SW1	SW2	g/Stk
WAS-06L	708.2400.060.20	500	10.0	27.0	15.0	19.0	14	12	34
WAS-08L	708.2400.080.20	500	12.0	29.0	15.0	23.0	17	12	47
WAS-10L	708.2400.100.20	500	14.0	30.5	15.5	24.0	19	14	61
WAS-12L	708.2400.120.20	400	16.0	32.5	15.5	25.0	22	17	78
WAS-15L	708.2400.150.20	400	19.0	37.0	16.0	30.0	27	19	127
WAS-18L	708.2400.180.20	400	22.0	40.5	17.0	33.0	32	24	204
WAS-22L	708.2400.220.20	250	27.0	44.5	17.0	37.0	36	27	261
WAS-28L	708.2400.280.20	250	32.0	47.5	17.0	42.0	41	36	382
WAS-06S	708.2400.060.30	800	11.0	31.0	15.0	23.0	17	12	54
WAS-08S	708.2400.080.30	800	13.0	32.0	15.0	24.0	19	14	71
WAS-10S	708.2400.100.30	800	15.0	34.5	17.0	25.0	22	17	96
WAS-12S	708.2400.120.30	630	17.0	38.5	17.0	29.0	24	17	123
WAS-14S	708.2400.140.30	630	19.0	40.5	18.5	30.0	27	19	154
WAS-16S	708.2400.160.30	630	21.0	44.0	19.5	33.0	30	24	230
WAS-20S	708.2400.200.30	420	26.0	49.5	23.0	37.0	36	27	327
WAS-25S	708.2400.250.30	420	31.0	55.5	25.5	42.0	46	36	589

Baumaße sind Ungefährmaße bei angezogener Überwurfmutter.

Nach dem Anschweißen die in der Montageanleitung angegebenen Stellen nochmals mit der ASW Fettpaste schmieren (Schneidring, Gewinde der Mutter).

Sizes are approximate dimensions at tightened nut.

After welding, coat the parts indicated in the assembly instructions with ASW grease (cutting ring, thread of nut).

Las medidas son aproximadas con la tuerca de unión apretada.

Luego de soldar, aplique nuevamente la grasa ASW en las partes indicadas en las instrucciones de montaje (anillo cortante, roscas de tuercas).

**Einschweiß-Schottstutzen**

**Weld-in bulkhead connectors**

**Cuerpos de paso de mamparo para soldar**

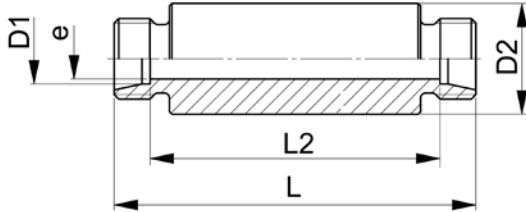

**XESV-..L/S**

Type -D1	Mat.-Nr.	PN	D2	L	L2	e	g/Stk
XESV-06L	706.1452.060.20	500	18.0	70.0	56.0	4.0	105
XESV-08L	706.1452.080.20	500	20.0	70.0	56.0	6.0	125
XESV-10L	706.1452.100.20	500	22.0	72.0	58.0	8.0	146
XESV-12L	706.1452.120.20	400	25.0	72.0	58.0	10.0	182
XESV-15L	706.1452.150.20	400	28.0	84.0	70.0	12.0	271
XESV-18L	706.1452.180.20	400	32.0	84.0	69.0	15.0	342
XESV-22L	706.1452.220.20	250	36.0	88.0	73.0	19.0	411
XESV-28L	706.1452.280.20	250	40.0	88.0	73.0	24.0	463
XESV-35L	706.1452.350.20	250	50.0	92.0	71.0	30.0	740
XESV-42L	706.1452.420.20	250	60.0	92.0	70.0	36.0	1028
XESV-06S	706.1452.060.30	800	20.0	74.0	60.0	4.0	139
XESV-08S	706.1452.080.30	800	22.0	74.0	60.0	5.0	167
XESV-10S	706.1452.100.30	800	25.0	74.0	59.0	7.0	207
XESV-12S	706.1452.120.30	630	28.0	74.0	59.0	8.0	256
XESV-14S	706.1452.140.30	630	30.0	88.0	72.0	10.0	344
XESV-16S	706.1452.160.30	630	35.0	88.0	71.0	12.0	452
XESV-20S	706.1452.200.30	420	38.0	92.0	71.0	16.0	528
XESV-25S	706.1452.250.30	420	45.0	96.0	72.0	20.0	742
XESV-30S	706.1452.300.30	420	50.0	100.0	73.0	25.0	899
XESV-38S	706.1452.380.30	420	60.0	104.0	72.0	32.0	1285

ISO 8434-1-WDBHS

**Einschweiß-Schottverschraubungen**

**Weld-in bulkhead fittings**

**Racores de paso de mamparo para soldar**

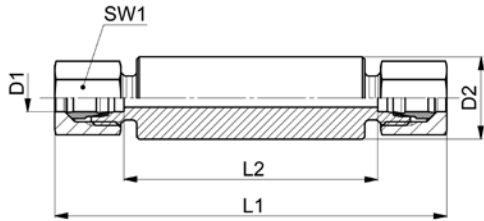

10

**ESV-..L/S**

Type -D1	Mat.-Nr.	PN	D2	L1	L2	SW1	g/Stk
ESV-06L	708.1452.060.20	500	18.0	86.0	56.0	14	127
ESV-08L	708.1452.080.20	500	20.0	86.0	56.0	17	155
ESV-10L	708.1452.100.20	500	22.0	88.0	58.0	19	184
ESV-12L	708.1452.120.20	400	25.0	88.0	58.0	22	236
ESV-15L	708.1452.150.20	400	28.0	100.0	70.0	27	360
ESV-18L	708.1452.180.20	400	32.0	102.0	69.0	32	480
ESV-22L	708.1452.220.20	250	36.0	106.0	73.0	36	590
ESV-28L	708.1452.280.20	250	40.0	106.0	73.0	41	668
ESV-35L	708.1452.350.20	250	50.0	114.0	71.0	50	1065
ESV-42L	708.1452.420.20	250	60.0	116.0	70.0	60	1530
ESV-06S	708.1452.060.30	800	20.0	90.0	60.0	17	177
ESV-08S	708.1452.080.30	800	22.0	90.0	60.0	19	210
ESV-10S	708.1452.100.30	800	25.0	92.0	59.0	22	272
ESV-12S	708.1452.120.30	630	28.0	92.0	59.0	24	333
ESV-14S	708.1452.140.30	630	30.0	108.0	72.0	27	454
ESV-16S	708.1452.160.30	630	35.0	108.0	71.0	30	590
ESV-20S	708.1452.200.30	420	38.0	114.0	71.0	36	748
ESV-25S	708.1452.250.30	420	45.0	120.0	72.0	46	1180
ESV-30S	708.1452.300.30	420	50.0	126.0	73.0	50	1390
ESV-38S	708.1452.380.30	420	60.0	134.0	72.0	60	2011

Baumaße sind Ungefährmaße bei angezogener Überwurfmutter.

Nach dem Anschweißen die in der Montageanleitung angegebenen Stellen nochmals mit der ASW Fettpaste schmieren (Schneidring, Gewinde der Mutter).

Sizes are approximate dimensions at tightened nut.

After welding, coat the parts indicated in the assembly instructions with ASW grease (cutting ring, thread of nut).

Las medidas son aproximadas con la tuerca de unión apretada.

Luego de soldar, aplique nuevamente la grasa ASW en las partes indicadas en las instrucciones de montaje (anillo cortante, roscas de tuercas).

**ISO 8434-1-WDBHSC**

## Schweißkegel

mit O-Ring

## Weldable cones

with O-ring

## Conos para soldar

con junta tórica

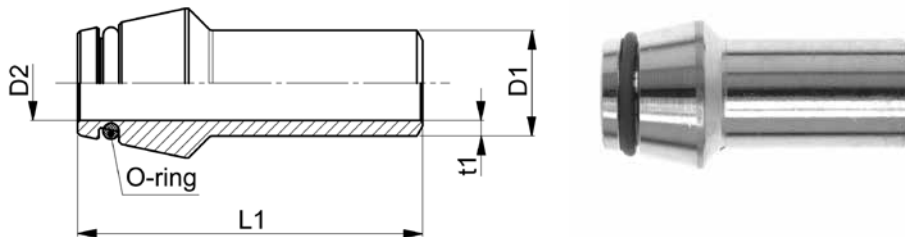

### SKO

Type-D1 x t1	Mat.-Nr.	D2	L1	O-ring	g/Stk
SKO-06x1,5	708.1453.061.30	3.0	31.0	4.0x1.5	6
SKO-08x1,5	708.1453.081.30	5.0	31.0	6.0x1.5	6
SKO-08x2,0	708.1453.082.30	4.0	31.0	6.0x1.5	10
SKO-10x1,5	708.1453.105.30	7.0	32.5	7.5x1.5	12
SKO-10x2,0	708.1453.108.30	6.0	32.5	7.5x1.5	14
SKO-12x1,5	708.1453.122.30	9.0	32.5	9.0x1.5	16
SKO-12x2,0	708.1453.125.30	8.0	32.5	9.0x1.5	18
SKO-12x2,5	708.1453.123.30	7.0	32.5	9.0x1.5	22
SKO-12x3,0	708.1453.124.30	6.0	32.5	9.0x1.5	24
SKO-14x2,0	708.1453.141.30	10.0	40.0	10.0x2.0	24
SKO-14x3,0	708.1453.142.30	8.0	40.0	10.0x2.0	34
SKO-15x2,0	708.1453.151.30	11.0	36.0	12.0x2.0	24
SKO-15x2,5	708.1453.152.30	10.0	36.0	12.0x2.0	30
SKO-16x2,0	708.1453.161.30	12.0	39.0	12.0x2.0	30
SKO-16x2,5	708.1453.162.30	11.0	39.0	12.0x2.0	36
SKO-16x3,0	708.1453.163.30	10.0	39.0	12.0x2.0	40
SKO-18x1,5	708.1453.181.30	15.0	36.0	15.0x2.0	24
SKO-18x2,0	708.1453.182.30	15.0	36.0	15.0x2.0	31
SKO-18x2,5	708.1453.183.30	13.0	36.0	15.0x2.0	38
SKO-20x2,0	708.1453.204.30	16.0	44.5	16.3x2.4	44
SKO-20x2,5	708.1453.201.30	15.0	44.5	16.3x2.4	54
SKO-20x3,0	708.1453.202.30	14.0	44.5	16.3x2.4	62
SKO-20x3,5	708.1453.205.30	13.0	44.5	16.3x2.4	70
SKO-20x4,0	708.1453.203.30	12.0	44.5	16.3x2.4	76
SKO-22x2,0	708.1453.221.30	18.0	38.5	20.0x2.0	40
SKO-22x2,5	708.1453.223.30	17.0	38.5	20.0x2.0	62
SKO-25x3,0	708.1453.253.30	19.0	49.5	20.3x2.4	88
SKO-25x3,5	708.1453.258.30	18.0	49.5	20.3x2.4	99
SKO-25x4,0	708.1453.255.30	18.0	49.5	20.3x2.4	110
SKO-25x5,0	708.1453.256.30	15.0	49.5	20.3x2.4	130
SKO-28x2,5	708.1453.281.30	23.0	41.5	26.0x2.0	70
SKO-28x3,0	708.1453.282.30	22.0	41.5	26.0x2.0	80

Fortsetzung nächste Seite

Continued on next page

Continuación página próxima

**Schweißkegel**

mit O-Ring

**Weldable cones**

with O-ring

**Conos para soldar**

con junta tórica

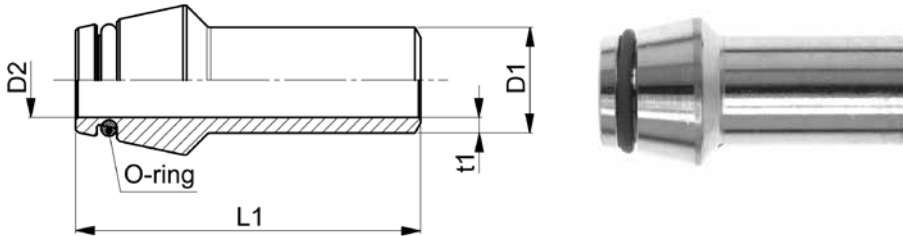

10

**SKO**

Type-D1 x t1	Mat.-Nr.	D2	L1	O-ring	g/Stk
SKO-30x3,0	708.1453.301.30	24.0	52.0	25.3x2.4	114
SKO-30x4,0	708.1453.302.30	22.0	52.0	25.3x2.4	142
SKO-30x5,0	708.1453.304.30	20.0	52.0	25.3x2.4	168
SKO-30x6,0	708.1453.306.30	18.0	52.0	25.3x2.4	192
SKO-35x3,0	708.1453.351.30	29.0	47.0	32.0x2.5	123
SKO-35x3,5	708.1453.352.30	28.0	47.0	32.0x2.5	138
SKO-35x4,0	708.1453.353.30	27.0	47.0	32.0x2.5	152
SKO-38x3,0	708.1453.384.30	32.0	56.5	33.3x2.4	160
SKO-38x4,0	708.1453.381.30	30.0	56.5	33.3x2.4	200
SKO-38x5,0	708.1453.385.30	28.0	56.5	33.3x2.4	242
SKO-38x6,0	708.1453.382.30	26.0	56.5	33.3x2.4	276
SKO-42x3,0	708.1453.993.30	36.0	47.0	38.0x2.5	150
SKO-42x4,0	708.1453.994.30	34.0	47.0	38.0x2.5	188

O-Ringe aus FKM werden separat mitgeliefert, erst nach dem Schweißvorgang aufziehen.

FKM O-rings supplied separately, to be fitted after welding.

Las juntas tóricas de FKM se suministran por separado; montarlas después de soldar.

passend in 24°-Innenkonus (Bohrungsform W DIN 3861)

fiting type 24° inside tapers (bore type W DIN 3861)

encaja en cono interior de 24° (forma de taladro W DIN 3861)

**ISO 8434-1-WDNP**

## Reduzierschweißkegel

mit O-Ring

## Weldable reducing cones

with O-ring

## Conos de reducción para soldar

con junta tórica

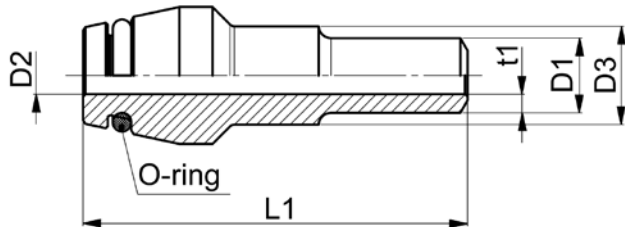

### SKR

Type-D3 / D1 x t1	Mat.-Nr.	D2	L1	O-ring	g/Stk
SKR-16/10x1,5	708.1454.471.31	7.0	38.5	12.0x2.0	38
SKR-16/10x2,0	708.1454.472.31	6.0	38.5	12.0x2.0	34
SKR-16/12x2,5	708.1454.483.31	7.0	38.5	12.0x2.0	42
SKR-20/16x2,0	708.1454.686.31	12.0	44.0	16.3x2.4	74
SKR-20/16x2,5	708.1454.687.31	11.0	44.0	16.3x2.4	76
SKR-20/16x3,0	708.1454.688.31	10.0	44.0	16.3x2.4	78
SKR-25/16x2,5	708.1454.802.31	11.0	49.0	20.3x2.4	100
SKR-25/20x3,0	708.1454.823.31	14.0	49.0	20.3x2.4	108
SKR-30/20x3,0	708.1454.930.31	14.0	51.5	25.3x2.4	169
SKR-30/25x3,0	708.1454.931.31	19.0	51.5	25.3x2.4	136
SKR-30/25x4,0	708.1454.932.31	17.0	51.5	25.3x2.4	166
SKR-38/16x2,0	708.1454.958.31	12.0	56.0	33.3x2.4	279
SKR-38/30x4,0	708.1454.974.31	22.0	56.0	33.3x2.4	286

O-Ringe aus FKM werden separat mitgeliefert, erst nach Schweißvorgang aufziehen.

FKM O-rings supplied separately, to be fitted after welding.

Las juntas tóricas de FKM se suministran por separado; montarlas después del proceso de soldado.

passend in 24°-Innenkonus  
(Bohrungsform W DIN 3861)

fitting type 24° inside tapers  
(bore type W DIN 3861)

encaja en cono interior de 24°  
(forma de taladro W DIN 3861)

**ISO 8434-1-WDRDNP**

## Verstärkungshülsen

für dünnwandige Rohre

## Reinforcing sleeves

for thin-walled tubes

## Manguitos de refuerzo

para tubos de pared delgada

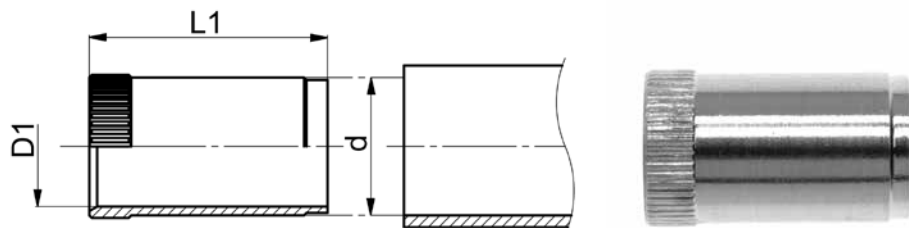

### VHS

Type -d	Mat.-Nr.	D1	L1	g/Stk
VHS-04	706.0030.059	2.5	15.5	1
VHS-05	706.0030.056	3.5	15.5	1
VHS-06	706.0030.080	4.5	15.5	1
VHS-07	706.0030.105	5.5	17.0	2
VHS-08	706.0030.103	6.5	17.0	2
VHS-09	706.0030.122	7.5	17.0	2
VHS-10	706.0030.121	8.5	17.0	2
VHS-11	706.0030.144	9.5	18.0	3
VHS-12	706.0030.154	10.0	18.0	4
VHS-13	706.0030.153	11.5	18.0	4
VHS-14	706.0030.165	12.0	18.0	5
VHS-15	706.0030.181	13.0	18.0	5
VHS-16	706.0030.185	14.0	22.0	6
VHS-17	706.0030.207	15.0	22.0	7
VHS-18	706.0030.206	16.0	22.0	8
VHS-19	706.0030.225	17.0	18.0	8
VHS-20	706.0030.224	18.0	18.0	8
VHS-21	706.0030.210	19.0	21.5	9
VHS-22	706.0030.252	20.0	24.0	10
VHS-24	706.0030.285	22.0	18.0	11
VHS-25	706.0030.284	23.0	18.0	11
VHS-31	706.0030.355	28.5	18.0	18
VHS-32	706.0030.320	29.5	23.0	18
VHS-33	706.0030.354	30.0	23.0	21
VHS-38	706.0030.996	35.5	24.0	25

**Montage:**

Hülse bis zum Rändelrand in das Rohr einstecken. Mit einem Hammer (Kunststoff oder Hartgummi) die Hülse ganz einschlagen. Hierbei wird der Rändelhals in die Innenwand des Rohres gepresst und sichert die Hülse gegen Verschieben oder Herausfallen.

Hinweise, für welche Rohre der Einsatz von Verstärkungshülsen empfohlen wird, finden Sie im Anhang, Kapitel a, unter "Edelstahlrohre".

**Assembly:**

Insert sleeve into tube up to the knurled edge. Use a hammer (plastic or hard rubber) to drive in the sleeve all the way. This will cause the knurled neck to be pressed into the inner wall of the tube and will secure the neck against being dislocated or falling out.

Information on which tube is recommended for use with reinforcing sleeves can be found in the appendix, Section a, under "Stainless Steel Tubes."

**Montaje:**

Introducir el casquillo en el tubo hasta el borde moleteado. Golpear completamente el casquillo utilizando un martillo (de plástico o goma dura). De este modo se presionará el cuello moleteado en la pared interior del tubo y se asegurará el casquillo contra el movimiento o la caída.

Encontrará indicaciones sobre los tubos recomendados para el uso de casquillos reforzados en el Anexo, Capítulo a, bajo "Tubos de acero inoxidable".

**Gewinde-Reduzierstutzen**

Abdichtung durch Dichtkante Form B nach DIN 3852-2

**Reducing adaptors**

sealing edge form B acc. DIN 3852-2

**Racores de reducción roscados**

cierre hermético mediante borde de obturación forma B según DIN 3852-2

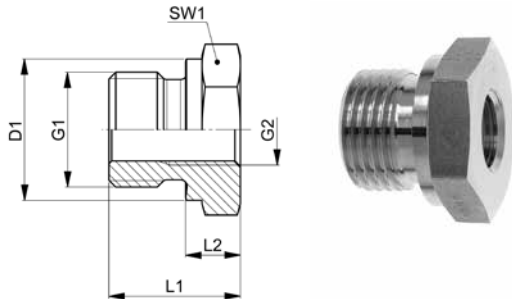

**RS-..**

Type-G1 /G2	Mat.-Nr.	PN	D1	G1	G2	L1	L2	SW1	g/Stk
G1=Rohrgewinde (zylindrisch)		G1=BSP thread (parallel)						G1=Rosca de conexión (cilíndrica)	
G2=Rohrgewinde (zylindrisch)		G2=BSP thread (parallel)						G2=Rosca de conexión (cilíndrica)	
RS-3.8/1.8	706.0411.162	800	22.0	3/8	1/8	22.5	10.5	22	40
RS-1.2/1.8	706.0411.221	800	26.0	1/2	1/8	24.0	10.0	27	65
RS-1.2/1.4	706.0411.224	800	26.0	1/2	1/4	24.0	10.0	27	57
RS-3.4/1.4	706.0411.284	800	32.0	3/4	1/4	26.0	10.0	32	105
RS-3.4/3.8	706.0411.286	800	32.0	3/4	3/8	26.0	10.0	32	94
RS-1.1/1.4	706.0411.406	630	39.0	1	1/4	29.0	11.0	41	195
RS-1.1/3.8	706.0411.407	630	39.0	1	3/8	29.0	11.0	41	177
RS-1.1/1.2	706.0411.408	630	39.0	1	1/2	29.0	11.0	41	155
RS-5.4/1.2	706.0411.488	420	49.0	1 1/4	1/2	32.0	12.0	50	320
RS-5.4/3.4	706.0411.490	420	49.0	1 1/4	3/4	32.0	12.0	50	264
RS-3.2/1.2	706.0411.511	420	55.0	1 1/2	1/2	36.0	14.0	55	486
RS-3.2/3.4	706.0411.513	420	55.0	1 1/2	3/4	36.0	14.0	55	430
RS-3.2/1.1	706.0411.512	420	55.0	1 1/2	1	36.0	14.0	55	346
RS-4.2/3.2	706.0411.617	420	68.0	2	1 1/2	43.0	19.0	70	547

**Gewinde-Reduzierstutzen**

Abdichtung durch Profildichtring Form E nach ISO 1179-2

**Reducing adaptors**

profile sealing ring form E acc. ISO 1179-2

**Racores de reducción roscados**

cierre hermético mediante junta con perfil forma E según ISO 1179-2

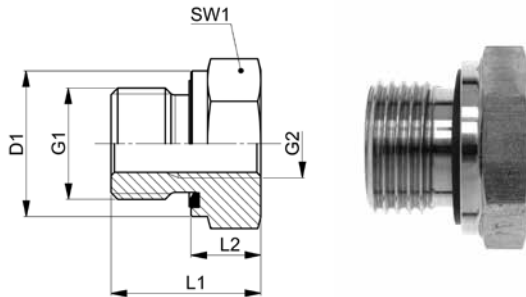

10

**RS..WD**

Type-G1 /G2	Mat.-Nr.	PN	D1	G1	G2	L1	L2	SW1	g/Stk
G1=Rohrgewinde (zylindrisch)		G1=BSP thread (parallel)						G1=Rosca de conexión (cilíndrica)	
G2=Rohrgewinde (zylindrisch)		G2=BSP thread (parallel)						G2=Rosca de conexión (cilíndrica)	
RS-3.8/1.8 WD	708.0416.162	800	22.0	3/8	1/8	22.5	10.5	22	40
RS-1.2/1.8 WD	708.0416.221	800	27.0	1/2	1/8	24.0	10.0	27	65
RS-1.2/1.4 WD	708.0416.224	800	27.0	1/2	1/4	24.0	10.0	27	57
RS-3.4/1.4 WD	708.0416.284	800	32.0	3/4	1/4	26.0	10.0	32	105
RS-3.4/3.8 WD	708.0416.286	800	32.0	3/4	3/8	26.0	10.0	32	94
RS-1.1/1.4 WD	708.0416.406	630	40.0	1	1/4	29.0	11.0	41	195
RS-1.1/3.8 WD	708.0416.407	630	40.0	1	3/8	29.0	11.0	41	177
RS-1.1/1.2 WD	708.0416.408	630	40.0	1	1/2	29.0	11.0	41	155
RS-5.4/1.2 WD	708.0416.488	420	50.0	1 1/4	1/2	32.0	12.0	50	310
RS-5.4/3.4 WD	708.0416.490	420	50.0	1 1/4	3/4	32.0	12.0	50	264
RS-3.2/1.2 WD	708.0416.511	420	55.0	1 1/2	1/2	36.0	14.0	55	480
RS-3.2/3.4 WD	708.0416.513	420	55.0	1 1/2	3/4	36.0	14.0	55	425
RS-3.2/1.1 WD	708.0416.512	420	55.0	1 1/2	1	36.0	14.0	55	344

Dichtungsmaterial: FKM

Sealing material: FKM

Material de junta tórica: FKM.

## Gewinde-Reduzierstutzen

Abdichtung durch Dichtkante Form B nach DIN 3852-2

## Reducing adaptors

sealing edge form B acc. DIN 3852-2

## Racores de reducción roscados

cierre hermético mediante borde de obturación forma B según DIN 3852-2

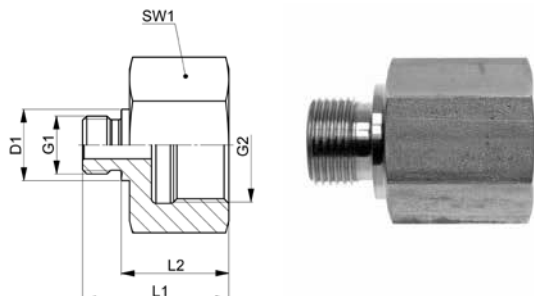

### RS-...

Type-G1 /G2	Mat.-Nr.	PN	D1	G1	G2	L1	L2	SW1	g/Stk
G1=Rohrgewinde (zylindrisch)		G1=BSP thread (parallel)						G1=Rosca de conexión (cilíndrica)	
G2=Rohrgewinde (zylindrisch)		G2=BSP thread (parallel)						G2=Rosca de conexión (cilíndrica)	
RS-1.8/1.4	706.0411.044	800	14.0	1/8	1/4	31.0	23.0	19	30
RS-1.8/3.8	706.0411.046	800	14.0	1/8	3/8	32.0	24.0	24	65
RS-1.4/1.8	706.0411.102	800	18.0	1/4	1/8	29.0	17.0	19	38
RS-1.4/3.8	706.0411.106	800	18.0	1/4	3/8	36.0	24.0	24	68
RS-1.4/1.2	706.0411.108	800	18.0	1/4	1/2	40.0	28.0	27	80
RS-1.4/3.4	706.0411.110	800	18.0	1/4	3/4	43.0	31.0	36	175
RS-3.8/1.4	706.0411.164	800	22.0	3/8	1/4	36.0	24.0	22	70
RS-3.8/1.2	706.0411.168	800	22.0	3/8	1/2	41.0	29.0	27	95
RS-3.8/3.4	706.0411.170	800	22.0	3/8	3/4	44.0	32.0	36	185
RS-1.2/3.8	706.0411.226	800	26.0	1/2	3/8	37.0	23.0	27	100
RS-1.2/3.4	706.0411.232	800	26.0	1/2	3/4	46.0	32.0	36	186
RS-1.2/1.1	706.0411.236	630	26.0	1/2	1	49.0	35.0	41	220
RS-1.2/5.4	706.0411.237	420	26.0	1/2	1 1/4	53.0	39.0	55	487
RS-3.4/1.2	706.0411.288	800	32.0	3/4	1/2	43.0	27.0	32	145
RS-3.4/1.1	706.0411.296	630	32.0	3/4	1	51.0	35.0	41	240
RS-3.4/5.4	706.0411.297	420	32.0	3/4	1 1/4	55.0	39.0	55	525
RS-3.4/3.2	706.0411.298	420	32.0	3/4	1 1/2	57.0	41.0	60	620
RS-1.1/3.4	706.0411.412	630	39.0	1	3/4	49.0	31.0	41	275
RS-1.1/5.4	706.0411.416	420	39.0	1	1 1/4	57.0	39.0	55	520
RS-1.1/3.2	706.0411.417	420	39.0	1	1 1/2	59.0	41.0	60	600
RS-5.4/1.1	706.0411.487	420	49.0	1 1/4	1	52.0	32.0	50	467
RS-5.4/3.2	706.0411.489	420	49.0	1 1/4	1 1/2	60.0	40.0	60	640
RS-3.2/5.4	706.0411.514	420	55.0	1 1/2	1 1/4	58.0	36.0	55	535

### Gewinde-Reduzierstutzen

Abdichtung durch Profildichtring Form E nach ISO 1179-2

### Reducing adaptors

profile sealing ring form E acc. ISO 1179-2

### Racores de reducción roscados

cierre hermético mediante junta con perfil forma E según ISO 1179-2

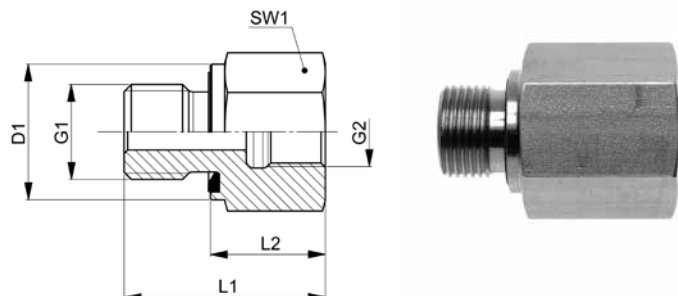

10

### RS...WD

Type-G1 /G2	Mat.-Nr.	PN	D1	G1	G2	L1	L2	SW1	g/Stk
G1=Rohrgewinde (zylindrisch)		G1=BSP thread (parallel)						G1=Rosca de conexión (cilíndrica)	
G2=Rohrgewinde (zylindrisch)		G2=BSP thread (parallel)						G2=Rosca de conexión (cilíndrica)	
RS-1.8/1.4 WD	708.0416.044	800	14.0	1/8	1/4	31.0	23.0	19	30
RS-1.8/3.8 WD	708.0416.046	800	14.0	1/8	3/8	32.0	24.0	24	65
RS-1.4/1.8 WD	708.0416.102	800	19.0	1/4	1/8	29.0	17.0	19	38
RS-1.4/3.8 WD	708.0416.106	800	19.0	1/4	3/8	36.0	24.0	24	68
RS-1.4/1.2 WD	708.0416.108	800	19.0	1/4	1/2	40.0	28.0	27	80
RS-1.4/3.4 WD	708.0416.110	800	19.0	1/4	3/4	43.0	31.0	36	175
RS-3.8/1.4 WD	708.0416.164	800	22.0	3/8	1/4	36.0	24.0	22	70
RS-3.8/1.2 WD	708.0416.168	800	22.0	3/8	1/2	41.0	29.0	27	95
RS-3.8/3.4 WD	708.0416.170	800	22.0	3/8	3/4	44.0	32.0	36	185
RS-1.2/3.8 WD	708.0416.226	800	27.0	1/2	3/8	37.0	23.0	27	100
RS-1.2/3.4 WD	708.0416.232	800	27.0	1/2	3/4	46.0	32.0	36	186
RS-1.2/1.1 WD	708.0416.236	630	27.0	1/2	1	49.0	35.0	41	220
RS-1.2/5.4 WD	708.0416.237	420	27.0	1/2	1 1/4	53.0	39.0	55	487
RS-3.4/1.2 WD	708.0416.288	800	32.0	3/4	1/2	43.0	27.0	32	145
RS-3.4/1.1 WD	708.0416.296	630	32.0	3/4	1	51.0	35.0	41	240
RS-3.4/5.4 WD	708.0416.297	420	32.0	3/4	1 1/4	55.0	39.0	55	525
RS-3.4/3.2 WD	708.0416.298	420	32.0	3/4	1 1/2	57.0	41.0	60	620
RS-1.1/3.4 WD	708.0416.412	630	40.0	1	3/4	49.0	31.0	41	275
RS-1.1/5.4 WD	708.0416.416	420	40.0	1	1 1/4	57.0	39.0	55	520
RS-1.1/3.2 WD	708.0416.417	420	40.0	1	1 1/2	59.0	41.0	60	600
RS-5.4/1.1 WD	708.0416.487	420	50.0	1 1/4	1	52.0	32.0	50	458
RS-5.4/3.2 WD	708.0416.489	420	50.0	1 1/4	1 1/2	60.0	40.0	60	640
RS-3.2/5.4 WD	708.0416.514	420	55.0	1 1/2	1 1/4	58.0	36.0	55	535

Dichtungsmaterial: FKM

Sealing material: FKM

Material de junta tórica: FKM.

**Verschlusschrauben**

mit Innensechskant, DIN 908, Abdichtung durch Dichtkante Form B nach DIN 3852-2

**Locking screws**

with internal hexagon, DIN 908, sealing edge form B acc. DIN 3852-2

**Tornillos de cierre**

con hexágono interior, DIN 908, cierre hermético mediante borde de obturación forma B según DIN 3852-2

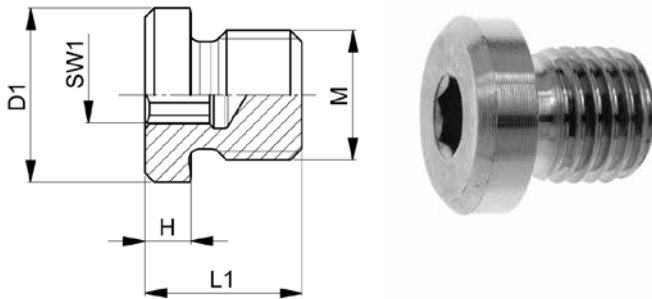

**VSI..M**

Type -M	Mat.-Nr.	PN	D1	M	H	L1	SW1	g/Stk
M=metrisches Gewinde (zylindrisch)		M=metric thread (parallel)			M=rosca métrica (cilíndrica)			
VSI-M 10x1,0	706.0723.150	800	14.0	10x1.0	4.0	12.0	5	6
VSI-M 12x1,5	706.0723.195	800	17.0	12x1.5	5.0	17.0	6	12
VSI-M 14x1,5	706.0723.225	800	19.0	14x1.5	5.0	17.0	6	20
VSI-M 16x1,5	706.0723.265	800	21.0	16x1.5	5.0	17.0	8	22
VSI-M 18x1,5	706.0723.305	800	23.0	18x1.5	5.0	17.0	8	32
VSI-M 20x1,5	706.0723.345	800	25.0	20x1.5	5.0	19.0	10	44
VSI-M 22x1,5	706.0723.375	800	27.0	22x1.5	5.0	19.0	10	50
VSI-M 26x1,5	706.0723.435	800	31.0	26x1.5	5.0	21.0	12	80
VSI-M 27x2,0	706.0723.400	800	32.0	27x2.0	5.0	21.0	12	80
VSI-M 33x2,0	706.0723.510	630	39.0	33x2.0	6.5	22.5	17	138
VSI-M 48x2,0	706.0723.748	420	55.0	48x2.0	6.5	22.5	24	210

**Verschlusschrauben**

mit Innensechskant, DIN 908, Abdichtung durch Profildichtring Form E nach ISO 1179-2

**Locking screws**

with internal hexagon, DIN 908, profile sealing ring form E acc. ISO 1179-2

**Tornillos de cierre**

con hexágono interior, DIN 908, cierre hermético mediante junta con perfil forma E según ISO 1179-2

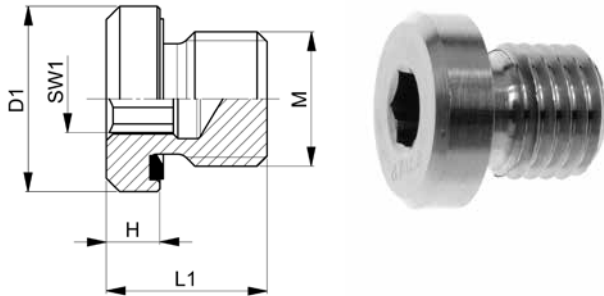

10

**VSI-..M WD**

Type -M	Mat.-Nr.	PN	D1	M	H	L1	SW1	g/Stk
M=metrisches Gewinde (zylindrisch)		M=metric thread (parallel)			M=rosca métrica (cilíndrica)			
VSI-M 10x1,0 WD	708.0724.150	800	14.0	10x1.0	4.0	12.0	5	6
VSI-M 12x1,5 WD	708.0724.195	800	17.0	12x1.5	5.0	17.0	6	12
VSI-M 14x1,5 WD	708.0724.225	800	19.0	14x1.5	5.0	17.0	6	20
VSI-M 16x1,5 WD	708.0724.265	800	22.0	16x1.5	5.0	17.0	8	22
VSI-M 18x1,5 WD	708.0724.305	800	24.0	18x1.5	5.0	17.0	8	32
VSI-M 20x1,5 WD	708.0724.345	800	26.0	20x1.5	5.0	19.0	10	44
VSI-M 22x1,5 WD	708.0724.375	800	27.0	22x1.5	5.0	19.0	10	50
VSI-M 26x1,5 WD	708.0724.435	800	32.0	26x1.5	5.0	21.0	12	80
VSI-M 27x2,0 WD	708.0724.400	630	32.0	27x2.0	5.0	21.0	12	80
VSI-M 33x2,0 WD	708.0724.510	630	40.0	33x2.0	6.5	22.5	17	138
VSI-M 42x2,0 WD	708.0724.642	420	50.0	42x2.0	6.5	22.5	22	208
VSI-M 48x2,0 WD	708.0724.748	420	55.0	48x2.0	6.5	22.5	24	210

Dichtungsmaterial: FKM

Sealing material: FKM

Material de junta tórica: FKM.

**Verschlusschrauben**

mit Innensechskant, DIN 908, Abdichtung durch Dichtkante Form B nach DIN 3852-2

**Locking screws**

with internal hexagon, DIN 908, sealing edge form B acc. DIN 3852-2

**Tornillos de cierre**

con hexágono interior, DIN 908, cierre hermético mediante borde de obturación forma B según DIN 3852-2

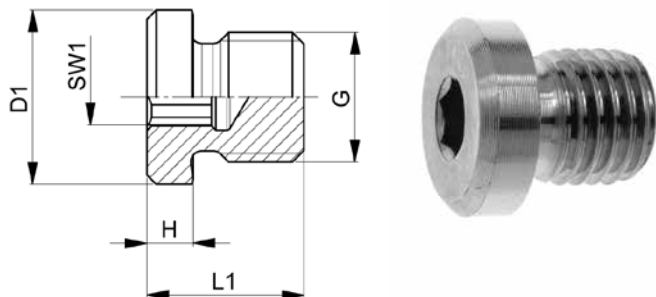

**VSI..R**

Type-G	Mat.-Nr.	PN	D1	G	H	L1	SW1	g/Stk
G=Rohrgewinde (zylindrisch)		G=BSP thread (parallel)			G=rosca de conexión (cilíndrica)			
VSI-R1.8	706.0721.020	800	14.0	1/8	4.0	12.0	5	6
VSI-R1.4	706.0721.040	800	18.0	1/4	5.0	17.0	6	18
VSI-R3.8	706.0721.060	800	22.0	3/8	5.0	17.0	8	26
VSI-R1.2	706.0721.080	800	26.0	1/2	5.0	19.0	10	44
VSI-R3.4	706.0721.120	800	32.0	3/4	5.0	21.0	12	76
VSI-R1.1	706.0721.160	630	39.0	1	6.5	22.5	17	126
VSI-R5.4	706.0721.180	420	49.0	1 1/4	6.5	22.5	22	192
VSI-R3.2	706.0721.200	420	55.0	1 1/2	6.5	22.5	24	268

**Verschlusschrauben**

mit Innensechskant, DIN 908, Abdichtung durch Profildichtring Form E nach ISO 1179-2

**Locking screws**

with internal hexagon, DIN 908, profile sealing ring form E acc. ISO 1179-2

**Tornillos de cierre**

con hexágono interior, DIN 908, cierre hermético mediante junta con perfil forma E según ISO 1179-2

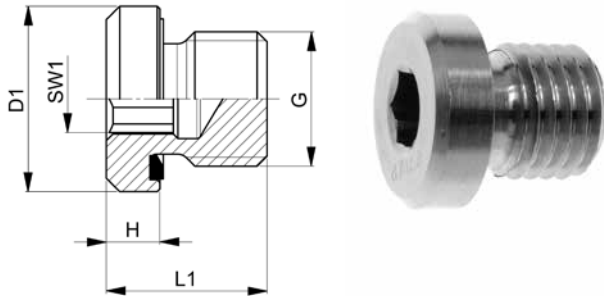

10

**VSI-..R WD**

Type-G	Mat.-Nr.	PN	D1	G	H	L1	SW1	g/Stk
G=Rohrgewinde (zylindrisch)		G=BSP thread (parallel)			G=rosca de conexión (cilíndrica)			
VSI-R1.8 WD	708.0722.020	800	14.0	1/8	4.0	12.0	5	6
VSI-R1.4 WD	708.0722.040	800	19.0	1/4	5.0	17.0	6	16
VSI-R3.8 WD	708.0722.060	800	22.0	3/8	5.0	17.0	8	29
VSI-R1.2 WD	708.0722.080	800	27.0	1/2	5.0	19.0	10	42
VSI-R3.4 WD	708.0722.120	800	32.0	3/4	5.0	21.0	12	76
VSI-R1.1 WD	708.0722.160	630	40.0	1	6.5	22.5	17	120
VSI-R5.4 WD	708.0722.180	420	50.0	1 1/4	6.5	22.5	22	186
VSI-R3.2 WD	708.0722.200	420	55.0	1 1/2	6.5	22.5	24	256

Dichtungsmaterial: FKM

Sealing material: FKM

Material de junta tórica: FKM.

**Verschlusschraube**

mit Außensechskant und Bund nach DIN 910, Abdichtung durch Dichtring Form A

**Locking screws**

with external hexagon and shoulder acc. to DIN 910, sealing ring form A

**Tornillos de cierre**

con hexágono exterior y collar según DIN 910, cierre hermético mediante junta forma A

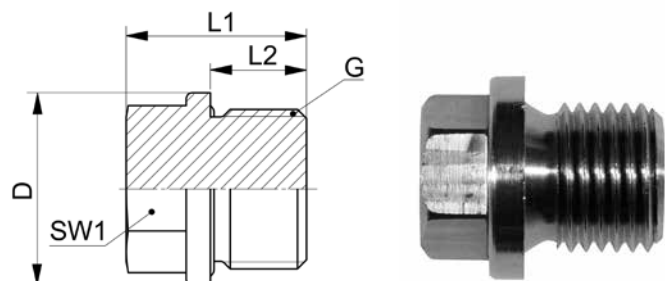

**VSS-..R**

Type -NPT	Mat.-Nr.	G	D	L1	L2	SW1	g/Stk
G=Rohrgewinde (zylindrisch)		G=BSP thread (parallel)				G=rosca de conexión (cilíndrica)	
VSS-R 1.8	706.0719.020	1/8	14.0	17.0	8.0	10	12
VSS-R 1.4	706.0719.040	1/4	18.0	21.0	12.0	13	26
VSS-R 3.8	706.0719.060	3/8	22.0	21.0	12.0	17	40
VSS-R 1.2	706.0719.080	1/2	26.0	26.5	14.0	19	70
VSS-R 3.4	706.0719.120	3/4	32.0	30.0	16.0	24	126
VSS-R 1.1	706.0719.160	1	39.0	32.0	16.0	27	199

**Verschlusschraube NPT**

mit Außensechskant

**Locking screws NPT**

with external hexagon

**Tornillos de cierre NPT**

con hexágono exterior

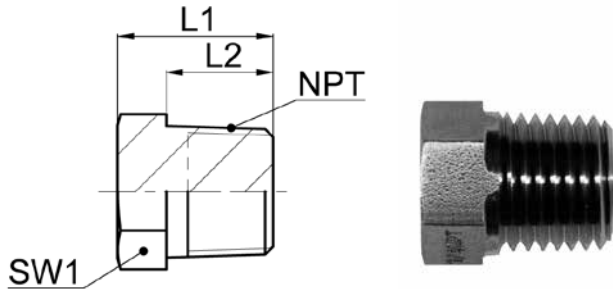

10

**VSS-..NPT**

Type -NPT	Mat.-Nr.	L1	L2	SW1	g/Stk
NPT=Einschraubgewinde NPT	NPT=tapered male adaptor thread NPT			NPT=rosca de conexión cónica NPT	
VSS-1.8NPT	706.0720.020.30	16.0	10.0	12	10
VSS-1.4NPT	706.0720.040.30	22.5	15.0	14	25
VSS-3.8NPT	706.0720.060.30	23.0	15.0	19	45
VSS-1.2NPT	706.0720.080.30	27.0	20.0	22	75
VSS-3.4NPT	706.0720.120.30	27.0	20.0	27	115
VSS-1.1NPT	706.0720.160.30	33.0	25.0	36	230

**Verschlussstopfen**

metallisch dichtend

**Blanking plugs**

metal-metal sealing

**Tapónes**

cierre metal/metal

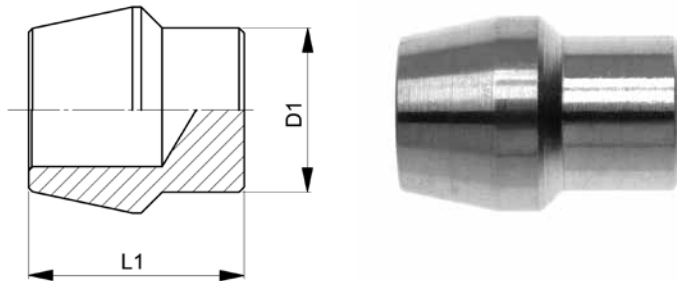

**VOE-..L/S**

Type-D1	Mat.-Nr.	PN	L1	g/Stk
VOE-06L/S	706.0033.060.13	630	17.5	4
VOE-08L/S	706.0033.080.13	630	18.5	8
VOE-10L/S	706.0033.100.13	630	19.5	17
VOE-12L/S	706.0033.120.13	630	19.5	22
VOE-15L	706.0033.150.20	400	19.5	24
VOE-18L	706.0033.180.20	400	20.0	31
VOE-22L	706.0033.220.20	250	20.5	52
VOE-28L	706.0033.280.20	250	21.5	97
VOE-35L	706.0033.350.20	250	24.0	176
VOE-42L	706.0033.420.20	250	25.0	234
VOE-14S	706.0033.140.30	630	20.0	24
VOE-16S	706.0033.160.30	630	21.0	34
VOE-20S	706.0033.200.30	630	24.0	57
VOE-25S	706.0033.250.30	630	25.0	104
VOE-30S	706.0033.300.30	630	26.5	151
VOE-38S	706.0033.380.30	630	30.0	213

passend in 24°-Innenkonus  
(Bohrungsform W DIN 3861)

fitting type 24° inside tapers  
(bore type W DIN 3861)

encaja en cono interior de 24°  
(forma de taladro W DIN 3861)

**Verschlussstopfen**

mit O-Ring

**Blanking plugs**

with O-ring

**Tapón**

con junta tórica

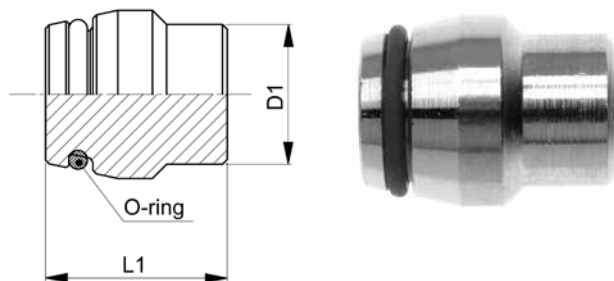

10

**VME-..L/S**

Type-D1	Mat.-Nr.	PN	L1	O-ring	g/Stk
VME-06L/S	708.0020.060.13	800	17.5	4.0x1.5	14
VME-08L/S	708.0020.080.13	800	18.5	6.0x1.5	17
VME-10L/S	708.0020.100.13	800	19.5	7.5x1.5	21
VME-12L/S	708.0020.120.13	630	19.5	9.0x1.5	25
VME-15L	708.0020.150.20	400	19.5	12.0x2.0	35
VME-18L	708.0020.180.20	400	20.0	15.0x2.0	45
VME-22L	708.0020.220.20	250	20.5	20.0x2.0	67
VME-28L	708.0020.280.20	250	21.5	26.0x2.0	100
VME-35L	708.0020.350.20	250	23.5	32.0x2.5	196
VME-42L	708.0020.420.20	250	25.0	38.0x2.5	257
VME-14S	708.0020.140.30	630	20.0	12.0x2.0	27
VME-16S	708.0020.160.30	630	21.0	12.0x2.0	37
VME-20S	708.0020.200.30	630	24.0	16.3x2.4	62
VME-25S	708.0020.250.30	420	25.0	20.3x2.4	108
VME-30S	708.0020.300.30	420	26.5	25.3x2.4	160
VME-38S	708.0020.380.30	420	30.0	33.3x2.4	231

passend in 24°-Innenkonus  
(Bohrungsform W DIN 3861)

fitting type 24° inside tapers  
(bore type W DIN 3861)

encaja en cono interior de 24°  
(forma de taladro W DIN 3861)

Dichtungsmaterial: FKM

Sealing material: FKM

Material de junta tórica: FKM.

**ISO 8434-1-PL**

# Überwurfmuttern

## Nuts

## Tuercas de unión

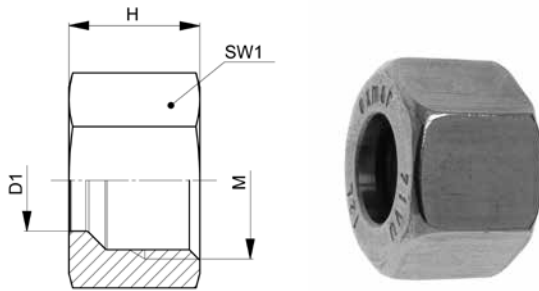

### UEM-..L/S

Type -D1	Mat.-Nr.	PN	M	H	SW1	g/Stk
M=metrisches Gewinde (zylindrisch)	M=metric thread (parallel)	M=rosca métrica (cilindrica)				
UEM-04LL	706.0200.040.10	100	08x1.0	11.0	10	4
UEM-06LL	706.0200.060.10	100	10x1.0	11.5	12	6
UEM-08LL	706.0200.080.10	100	12x1.0	12.0	14	7
UEM-10LL	706.0200.100.10	100	14x1.0	12.5	17	11
UEM-12LL	706.0200.120.10	100	16x1.0	13.0	19	13
UEM-06L	706.0200.060.20	500	12x1.5	14.5	14	10
UEM-08L	706.0200.080.20	500	14x1.5	14.5	17	15
UEM-10L	706.0200.100.20	500	16x1.5	15.5	19	19
UEM-12L	706.0200.120.20	400	18x1.5	15.5	22	25
UEM-15L	706.0200.150.20	400	22x1.5	17.0	27	41
UEM-18L	706.0200.180.20	400	26x1.5	18.0	32	63
UEM-22L	706.0200.220.20	250	30x2.0	20.0	36	83
UEM-28L	706.0200.280.20	250	36x2.0	21.0	41	91
UEM-35L	706.0200.350.20	250	45x2.0	24.0	50	147
UEM-42L	706.0200.420.20	250	52x2.0	24.0	60	231
UEM-06S	706.0200.060.30	800	14x1.5	16.5	17	16
UEM-08S	706.0200.080.30	800	16x1.5	16.5	19	19
UEM-10S	706.0200.100.30	800	18x1.5	17.5	22	29
UEM-12S	706.0200.120.30	630	20x1.5	17.5	24	34
UEM-14S	706.0200.140.30	630	22x1.5	20.5	27	50
UEM-16S	706.0200.160.30	630	24x1.5	20.5	30	64
UEM-20S	706.0200.200.30	420	30x2.0	24.0	36	103
UEM-25S	706.0200.250.30	420	36x2.0	27.0	46	212
UEM-30S	706.0200.300.30	420	42x2.0	29.0	50	233
UEM-38S	706.0200.380.30	420	52x2.0	32.5	60	341

Überwurfmuttern auch innen versilbert erhältlich  
Art. NC-UEM, siehe Kapitel 20.

Nuts also available inside silver-plated:  
Art. NC-UEM, see chapter 20.

Tuercas de unión disponibles también con interior plateado:  
Art. NC-UEM, véase capítulo 20.

**ISO 8434-1-N**

**Schneidringe**

nach DIN 3861

**Cutting rings**

according to DIN 3861

**Anillos cortantes**

según DIN 3861

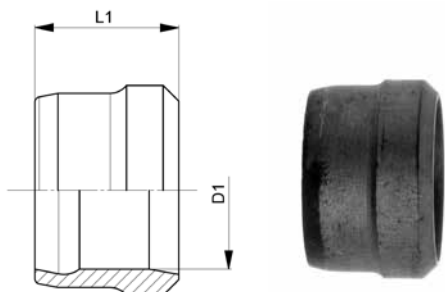

10

**SR-..L/S**

Type-D1	Mat.-Nr.	PN	L1	g/Stk
SR-06L/S	706.0021.060.13	800	9.0	2
SR-08L/S	706.0021.080.13	800	9.0	2
SR-10L/S	706.0021.100.13	800	10.0	3
SR-12L/S	706.0021.120.13	630	10.0	3
SR-04LL	706.0021.040.10	100	6.0	1
SR-06LL	706.0021.060.10	100	7.0	1
SR-08LL	706.0021.080.10	100	7.0	1
SR-10LL	706.0021.100.10	100	7.0	1
SR-12LL	706.0021.120.10	100	7.5	2
SR-15L	706.0021.150.20	400	10.0	4
SR-18L	706.0021.180.20	400	10.0	5
SR-22L	706.0021.220.20	250	10.5	7
SR-28L	706.0021.280.20	250	10.5	8
SR-35L	706.0021.350.20	250	13.0	17
SR-42L	706.0021.420.20	250	13.5	22
SR-14S	706.0021.140.30	630	10.0	4
SR-16S	706.0021.160.30	630	10.5	5
SR-20S	706.0021.200.30	420	12.5	9
SR-25S	706.0021.250.30	420	12.5	12
SR-30S	706.0021.300.30	420	13.0	16
SR-38S	706.0021.380.30	420	13.5	23

**ISO 8434-1-CR**

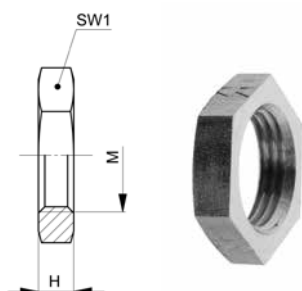
**Kontermuttern**
**Counter nuts**
**Contratuercas**

**KM-..L/S**

Type -D1	Mat.-Nr.	M	H	SW1	g/Stk
M=metrisches Gewinde (zylindrisch)	M=metric thread (parallel)	M=rosca métrica (cilindrica)			
KM-06S/08L	706.0063.225.13	14x1.5	6.0	19	7
KM-08S/10L	706.0063.265.13	16x1.5	6.0	22	10
KM-10S/12L	706.0063.305.13	18x1.5	6.0	24	12
KM-14S/15L	706.0063.375.13	22x1.5	7.0	30	24
KM-20S/22L	706.0063.470.13	30x2.0	8.0	41	52
KM-25S/28L	706.0063.560.13	36x2.0	9.0	46	64
KM-38S/42L	706.0063.652.13	52x2.0	10.0	65	130
KM-06L	706.0063.195.20	12x1.5	6.0	17	6
KM-18L	706.0063.435.20	26x1.5	8.0	36	36
KM-35L	706.0063.745.20	45x2.0	9.0	55	78
KM-12S	706.0063.345.30	20x1.5	7.0	27	21
KM-16S	706.0063.405.30	24x1.5	7.0	32	39
KM-30S	706.0063.642.30	42x2.0	9.0	50	78

**ISO 8434-1-LN**

**Dichtringe**

für Außengewinde von Schwenkverschraubungen

**Seal rings**

for external threads of banjo fittings

**Anillos de obturación**

para roscas exteriores de racores orientables

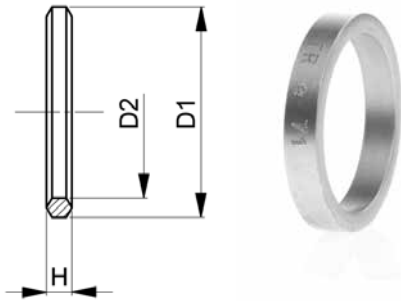

**EDKR-..M/R**

Type -M	Mat.-Nr.	D1	D2	H	g/Stk
M=metrisches Gewinde (zylindrisch)	M=metric thread (parallel)			M=rosca métrica (cilíndrica)	
EDKR-M 10x1,0/R 1.8	706.0126.150	14.0	10.0	2.5	1
EDKR-M 12x1,5/M 14x1,5/R 1.4	706.0126.225	18.0	14.0	3.0	2
EDKR-M 16x1,5/R 3.8	706.0126.265	21.0	17.0	3.0	2
EDKR-M 18x1,5	706.0126.305	23.0	18.0	3.0	3
EDKR-M 20x1,5/M 22x2,0/R 1.2	706.0126.375	27.0	22.0	4.5	5
EDKR-M 26x1,5/M 27x2,0/R 3.4	706.0126.440	32.0	27.0	3.5	4
EDKR-M 33x2,0/R 1.1	706.0126.510	39.0	33.5	3.5	5
EDKR-M 42x2,0/R 5.4	706.0126.642	49.0	42.0	3.5	9
EDKR-M 48x2,0/R 3.2	706.0126.748	55.0	48.0	3.5	11

Type -G	Mat.-Nr.	D1	D2	H	g/Stk
G=Rohrgewinde (zylindrisch)	G=BSP thread (parallel)			G=rosca de conexión (cilíndrica)	
EDKR-M 10x1,0/R 1.8	706.0126.150	14.0	10.0	2.5	1
EDKR-M 12x1,5/M 14x1,5/R 1.4	706.0126.225	18.0	14.0	3.0	2
EDKR-M 16x1,5/R 3.8	706.0126.265	21.0	17.0	3.0	2
EDKR-M 20x1,5/M 22x2,0/R 1.2	706.0126.375	27.0	22.0	4.5	5
EDKR-M 26x1,5/M 27x2,0/R 3.4	706.0126.440	32.0	27.0	3.5	4
EDKR-M 33x2,0/R 1.1	706.0126.510	39.0	33.5	3.5	5
EDKR-M 42x2,0/R 5.4	706.0126.642	49.0	42.0	3.5	9
EDKR-M 48x2,0/R 3.2	706.0126.748	55.0	48.0	3.5	11

M/G für Außengewinde nach ISO 228/1

M/G for male threads ISO 228/1

M/G para roscas exteriores ISO 228/1

**Dichtkantenringe**

für Innengewinde für Manometer-Verschraubungen

**Seal edge rings**

for internal threads for manometer fittings

**Anillos con borde de obturación**

para roscas interiores de racores manométricos

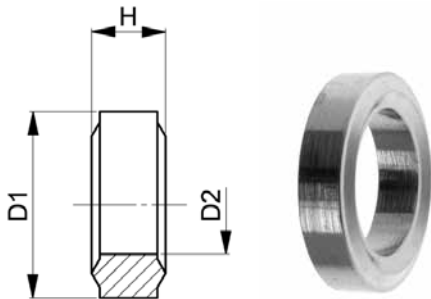

**DKR-..R**

Type -M	Mat.-Nr.	D1	D2	G	H	g/Stk
G=Rohrgewinde (zylindrisch)		G=BSP thread (parallel)		G=rosca de conexión (cilíndrica)		
DKR-R 1.4	706.0023.040	11.5	6.0	1/4	4.5	1
DKR-R 1.2	706.0023.080	18.5	12.0	1/2	5.0	4

für Innengewinde ISO 228/1

for internal threads ISO 228/1

para roscas interiores ISO 228/1

**Profildichtringe**

Material: FKM

**Profile sealing rings**

Material: FKM

**Juntas anulares con perfil**

Material: FKM

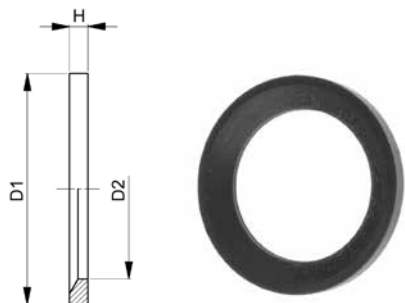

10

**VDR-..M/R**

Type-G / M	Mat.-Nr.	D1	D2	G	M	H	g/Stk
G=Rohrgewinde (zylindrisch)	G=BSP thread (parallel)				G=rosca de conexión (cilíndrica)		
VDR-R 3.8	XNN.62381.4715	19.0	14.5	3/8		1.5	1
VDR-R 1.2	XNN.62381.8515	24.0	18.5	1/2		1.5	1
VDR-M 12x1,5	XNN.62380.9815	14.5	10.0		12x1.5	1.5	1
VDR-M 16x1,5	XNN.62381.3815	19.0	14.0		16x1.5	1.5	1
VDR-M 18x1,5	XNN.62381.5715	21.0	15.5		18x1.5	1.5	1
VDR-M 20x1,5	XNN.62381.7815	23.0	18.0		20x1.5	1.5	1
VDR-M 22x1,5	XNN.62381.9615	24.5	19.5		22x1.5	1.5	1
VDR-R 1.8/M 10x1,0	XNN.62380.8410	12.0	8.5	1/8	10x1.0	1.0	1
VDR-R 1.4/M 14x1,5	XNN.62381.1615	16.5	11.5	1/4	14x1.5	1.5	1
VDR-R 3.4/M 26/27	XNN.62382.3915	29.0	24.0	3/4	27x2.0	1.5	1
VDR-R 1.1/M 33x2,0	XNN.62382.9720	35.5	29.5	1	33x2.0	2.0	1
VDR-R 5.4/M 42x2,0	XNN.62383.8820	46.0	39.0	1 1/4	42x2.0	2.0	1
VDR-R 3.2/M 48x2,0	XNN.62384.4720	50.5	44.5	1 1/2	48x2.0	2.0	1

M/G Außengewinde

M/G external threads

Rosca exterior M/G

**DIN 3869  
ISO 1179**

**O-Ringe**

Material: FKM

**O-rings**

Material: FKM

**Juntas tóricas**

Material: FKM

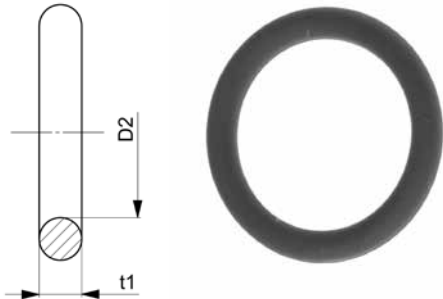

**VOR**

Type -D2 x t1	Mat.-Nr.	D1	g/Stk
VOR-4x1.5	XNN.61380.403	6.0	1
VOR-7.5x1.5	XNN.61380.753	10.0	1
VOR-8x1	XNN.61380.802	8.0	1
VOR-9x1.5	XNN.61380.903	12.0	1
VOR-12x2	XNN.61381.206	16.0	1
VOR-15x2	XNN.61381.506	18.0	1
VOR-16.3x2.4	XNN.61381.634	20.0	1
VOR-20x2	XNN.61382.004	22.0	1
VOR-20.3x2.4	XNN.61382.034	25.0	1
VOR-25.3x2.4	XNN.61382.534	30.0	1
VOR-26x2	XNN.61382.606	28.0	1
VOR-32x2.5	XNN.61383.205	35.0	1
VOR-33.3x2.4	XNN.61383.333	38.0	1
VOR-38x2.5	XNN.61383.803	42.0	1

VOR-12x2, XNN.61381.206, passend für D1 = 14 mm, 15 mm und 16 mm

VOR-12x2, XNN.61381.206, for D1 = 14 mm, 15 mm and 16 mm

VOR-12x2, XNN.61381.206, por D1 = 14 mm, 15 mm y 16 mm

D1 = Größe des Dichtkegelanschlusses

D1 = dimension of the taper connection

D1 = medida de la conexión de junta cónica

# EXmar

**Полный каталог компании можно посмотреть на нашем сайте  
[www.lengopro.ru](http://www.lengopro.ru)  
просто наведите камеру смартфона на QR-код ниже**



**Контакты компании, сервисных мастерских и схемы проезда  
можно посмотреть по QR-коду ниже**



При подготовке настоящего каталога мы конечно-же были предельно внимательны к деталям и размещаемой информации, но ЛенГо Индастриал Техникс не несет ответственности за любые непреднамеренные типографские ошибки, опечатки или упущения, а так-же, любые изменения, вносимые производителем. Информация может быть изменена без предварительного уведомления. Информация в этом каталоге является точной только на дату публикации и приводится для справки. Компания-производитель оставляет за собой право изменять свою продукцию без предварительного уведомления своих клиентов, дистрибьюторов, представителей и продавцов.

Эти изменения могут быть внесены в приобретенные продукты. Использованные в публикации логотипы являются торговыми марками и зарегистрированы надлежащим образом, иллюстрации защищены законом об авторском праве - не допускается использование и воспроизведение публикации/каталога полностью или его любой части без письменного разрешения правообладателя.

Пожалуйста, узнавайте точную информацию у наших специалистов!